



County Council Meeting Beaufort County, SC

Council Chambers, Administration Building Beaufort County Government Robert Smalls
Complex 100 Ribaut Road, Beaufort

Monday, October 09, 2023
5:00 PM

AGENDA

COUNCIL MEMBERS:

JOSEPH F. PASSIMENT, CHAIRMAN
DAVID P. BARTHOLOMEW
LOGAN CUNNINGHAM
YORK GLOVER
MARK LAWSON
ANNA MARIA TABERNIK

LAWRENCE MCELYNN, VICE CHAIR
PAULA BROWN
GERALD DAWSON
ALICE HOWARD
THOMAS REITZ

1. CALL TO ORDER
2. PLEDGE OF ALLEGIANCE AND INVOCATION- Council Member Anna Maria Tabernik
3. PUBLIC NOTIFICATION OF THIS MEETING HAS BEEN PUBLISHED, POSTED, AND DISTRIBUTED IN COMPLIANCE WITH THE SOUTH CAROLINA FREEDOM OF INFORMATION ACT
4. APPROVAL OF AGENDA
- [5.](#) APPROVAL OF MINUTES - August 21, 2023; August 24, 2023; August 28, 2023 1st meeting; August 28, 2023 2nd Meeting.
6. ADMINISTRATOR'S REPORT
- [7.](#) PROCLAMATION RECOGNIZING BULLYING PREVENTION AWARENESS MONTH - Council Member Anna Maria Tabernik

CITIZEN COMMENTS

[8.](#) **CITIZEN COMMENT PERIOD - 15 MINUTES TOTAL**

Anyone who wishes to speak during the Citizen Comment portion of the meeting will limit their comments to AGENDA ITEMS ONLY and speak no longer than three (3) minutes. Speakers will address Council in a respectful manner appropriate to the decorum of the meeting, refraining from the use of profane, abusive, or obscene language. In accordance with Beaufort County's Rules and Procedures, giving of a speaker's time to another is not allowed.

COMMITTEE REPORTS

9. LIASION AND COMMITTEE REPORTS

PUBLIC HEARINGS AND ACTION ITEMS

10. APPROVAL OF CONSENT AGENDA
- [11.](#) THIRD READING OF AN ORDINANCE AUTHORIZING THE COUNTY ADMINISTRATOR TO EXECUTE THE NECESSARY DOCUMENTS AND PROVIDE FUNDING FOR THE PURCHASE OF REAL PROPERTY IDENTIFIED AS 34 ULMER ROAD (**FISCAL IMPACT: \$3,150,000 Purchase Price plus closing costs and to include all due diligence costs. Funding source is the General Fund- Fund Balance**)
- Vote at First Reading on July 10, 2023- 11:0*
- Vote at Public Hearing and Second Reading on August 14, 2023: Postpone until September 25, 2023- 11:0*
- Vote at Public Hearing and Second Reading on September 25, 2023 - 9:2*
- [12.](#) PUBLIC HEARING AND THIRD READING OF AN ORDINANCE AUTHORIZING THE HILTON HEAD NO. 1 PUBLIC SERVICE DISTRICT, SOUTH CAROLINA TO ISSUE NOT EXCEEDING \$23,000,000 OF GENERAL OBLIGATION BONDS; AND PROVIDING FOR OTHER MATTERS RELATED THERETO
- Vote at First Reading on September 11, 2023- 10:0*
- Vote at Second Reading on September 25, 2023- 11:0*
- [13.](#) PUBLIC HEARING AND SECOND READING OF AN ORDINANCE FOR A PROPOSED TEXT AMENDMENT TO ARTICLE 7, DIVISION 7.4, SECTION 7.4.50 (PUBLIC HEARING SCHEDULING AND NOTICE) AND SECTION 7.4.70 (PUBLIC HEARING PROCEDURES) TO CLARIFY THAT PUBLIC COMMENT IS NOT TAKEN FOR APPEALS TO THE PLANNING COMMISSION OR THE ZONING BOARD OF APPEALS
- Vote at First Reading on September 25, 2023- 11:0*
- [14.](#) PUBLIC HEARING AND SECOND READING OF AN ORDINANCE ADOPTING AMENDMENTS TO CH 38. ARTICLE II. TRASH AND LITTER CONTROL OF THE BEAUFORT COUNTY CODE OF ORDINANCES
- Vote at First Reading on September 25, 2023- 11:0*
- [15.](#) PUBLIC HEARING AND SECOND READING OF AN ORDINANCE ADOPTING AMENDMENTS TO CHAPTER 62, SOLID WASTE, BEAUFORT COUNTY CODE OF ORDINANCES
- Vote at First Reading on September 25, 2023- 11:0*
- [16.](#) FIRST READING OF AN ORDINANCE AUTHORIZING THE INTERIM COUNTY ADMINISTRATOR TO EXECUTE ANY AND ALL DOCUMENTS NECESSARY TO ACCEPT RIGHT OF WAY ON DIANAH'S DRIVE
- [17.](#) FIRST READING OF AN ORDINANCE AUTHORIZING THE INTERIM COUNTY ADMINISTRATOR TO ENTER INTO A LEASE AGREEMENT FOR REAL PROPERTY LOCATED AT 30 HUNTER ROAD WITH EDISON FOARD, INC. (**FISCAL IMPACT: Hilton Head Island Airport will receive income generated through lease revenue - -Tenant shall pay \$1,390.00 for office space (814 square feet x \$20.50/12) and \$1,698 for warehouse space (1,406 square feet x \$14.50/12) in monthly base rental payments for premises located at 30 Hunter Rd. These lease rates are in accordance with current Beaufort County lease policies**)
- [18.](#) FIRST READING OF AN ORDINANCE AUTHORIZING THE INTERIM COUNTY ADMINISTRATOR TO ENTER INTO A LEASE AGREEMENT FOR REAL PROPERTY LOCATED AT 39 AIRPORT CIRCLE WITH HIGH TIDE AVIATION SCENIC TOURS (**FISCAL IMPACT: Beaufort Executive Airport will receive income generated through fuel sales, the airport's standard 3% operating agreement, and lease revenue --Tenant shall pay \$231.00 (140 square feet x \$19.80/12) in monthly base rental payments for premises located at the Beaufort**

Executive Airport terminal. These lease rates are in accordance with current Beaufort County lease policies)

- 19. APPROVAL OF A RESOLUTION TO ENTER INTO AN INTERGOVERNMENTAL SUPPORT AGREEMENT (IGSA) WITH THE DEPARTMENT OF DEFENSE TO SUPPORT OPERATIONS AT THE MARINE CORPS RECRUIT DEPOT PARRIS ISLAND (MCRD PARRIS ISLAND), THE MARINE CORPS AIR STATION (MCAS) AND THE NAVAL HOSPITAL BY PROVIDING GENERAL GOVERNMENTAL SERVICES **(FISCAL IMPACT: In each and every task order, the County would quote a fee that covers all time and material costs to perform the identified work)**
- 20. APPROVAL OF A RESOLUTION FOR AN ADDENDUM TO A 2020 MEMORANDUM OF UNDERSTANDING (MOU) WITH THE TOWN OF HILTON HEAD FOR THE ST. JAMES BAPTIST CHURCH RELOCATION PROJECT **(FISCAL IMPACT: As part of the original MOU, both the Town and County deposited \$150,000 each, totaling \$300,000, into an account to share in the costs to prepare all of the preliminary documentation and studies necessary to secure FAA grant funding for the relocation of the Church and School. To date, there are still sufficient funds in the account for the expected expenses, and no additional funding is required by this Addendum)**
- 21. APPROVAL OF A RESOLUTION AUTHORIZING THE INTERIM ADMINISTRATOR TO ENTER INTO A MOA BETWEEN BEAUFORT COUNTY AND THE CITY OF BEAUFORT TO EXPLORE THE FEASIBILITY OF CO-LOCATING MUNICIPAL FIRE SERVICE AND COUNTY EMS **(FISCAL IMPACT: Funds in the amount of \$25,000+/- are allocated to the building of a new EMS station in the CIP budget Account #10401230-54420. The balance is \$1.5 Million)**

CITIZEN COMMENTS

22. CITIZEN COMMENT PERIOD- 15 MINUTES TOTAL

Anyone who wishes to speak during the Citizen Comment portion of the meeting will limit their comments and speak no longer than three (3) minutes. Speakers will address Council in a respectful manner appropriate to the decorum of the meeting, refraining from the use of profane, abusive, or obscene language. In accordance with Beaufort County's Rules and Procedures, giving of a speaker's time to another is not allowed.

EXECUTIVE SESSION

- 23. PURSUANT TO S. C. CODE §30-4-70(A)(2): RECEIPT OF LEGAL ADVICE WHERE THE LEGAL ADVICE RELATES TO MATTERS COVERED BY THE ATTORNEY-CLIENT PRIVILEGE (REVIEW OF REZONING REQUESTS UNDER THE COMMUNITY DEVELOPMENT CODE)
 - 24. PURSUANT TO S. C. CODE SECTION 30-4-70(A)(2) TO RECEIVE LEGAL ADVICE WHERE THE ADVICE RELATES TO PENDING LITIGATION (PERSONNEL EMPLOYMENT LITIGATION)
 - 25. PURSUANT TO S. C. CODE SECTION 30-4-70(A)(2) TO RECEIVE LEGAL ADVICE WHERE THE ADVICE RELATES TO POTENTIAL LITIGATION (NOTICE OF POTENTIAL ACTION)
-

END OF EXECUTIVE SESSION

Matters Arising Out of the Executive Session

- 26. ADJOURNMENT

CONSENT AGENDA

Items Originating from the Public Facilities and Safety Committee

1. APPROVAL OF CONTRACT AWARD TO FIRST CONSTRUCTION MANAGEMENT FOR IFB #082423E SPANISH MOSS TRAIL PORT ROYAL EXTENSION (**FISCAL IMPACT: \$977,253.24 with funding for this project will be Rail Trail account # 48060011-54435 with a balance of \$670,437.00 and TAG account # 2342001T-54500 with a balance of \$5,643,326.00**)
2. APPROVAL OF CONTRACT AWARD TO BEAUFORT CONSTRUCTION OF SC, LLC FOR IFB #052523 PORT ROYAL PUBLIC LIBRARY CONSTRUCTION SERVICES (**FISCAL IMPACT: \$480,000.00 from funding source 26030011-54420 - Library Impact Fees. Current account balance is \$606,400**)
3. APPROVAL TO PURCHASE A 2023 PETERBILT 547 VACUUM TRUCK (**FISCAL IMPACT: a quote was provided from AQUP from Sourcewell in the amount of \$570,000 to come from the Stormwater account with a balance of \$644,000**)

END OF CONSENT AGENDA

TO WATCH COMMITTEE OR COUNTY COUNCIL MEETINGS OR FOR A COMPLETE LIST OF AGENDAS AND BACKUP PACKAGES, PLEASE VISIT:

<https://beaufortcountysc.gov/council/council-committee-meetings/index.html>



Special Called Meeting of County Council Meeting Beaufort County, SC

Council Chambers, Administration Building Beaufort County Government Robert Smalls
Complex 100 Ribaut Road, Beaufort

Monday, August 21, 2023
4:00 PM

MINUTES

Watch the video stream available on the County's website to hear the Council's discussion of a specific topic or the complete meeting. <https://beaufortcountysc.new.swagit.com/videos/269664>

1. CALL TO ORDER

Chairman Passiment called the meeting to order at 4:46 PM.

PRESENT

Chairman Joseph F. Passiment
Vice-Chairman Lawrence McElynn
Council Member David P. Bartholomew
Council Member Paula Brown
Council Member Logan Cunningham
Council Member Gerald Dawson
Council Member York Glover (arrived late)
Council Member Alice Howard
Council Member Mark Lawson
Council Member Anna Maria Tabernik

2. PLEDGE OF ALLEGIANCE AND INVOCATION

Chairman Passiment led the Pledge of Allegiance.

3. FOIA

Chairman Passiment noted that public notification of this meeting had been published, posted, and distributed in compliance with the South Carolina Freedom of Information Act.

4. APPROVAL OF AGENDA

Motion: It was moved by Council Member Cunningham, seconded by Council Member Bartholomew, to approve the agenda.

The Vote: The motion was approved without objection.

5. CITIZEN COMMENT PERIOD

No citizen comments.

6. SECOND READING OF AN ORDINANCE AMENDMENT TO PROVIDE FOR A MODIFIED MILLAGE RATE FOR THE LEVY OF TAX FOR SCHOOL PURPOSES FOR BEAUFORT COUNTY FOR THE FISCAL YEAR BEGINNING JULY 1, 2023, AND ENDING JUNE 30, 2024, AND TO MAKE APPROPRIATIONS FOR SAID PURPOSES

Motion: It was moved by Council Member Tabernik, seconded by Council Member Howard, to approve the second reading of an ordinance amendment to provide for a modified millage rate for the levy of tax for school purposes for Beaufort County for the fiscal year beginning July 1, 2023, and ending June 30, 2024, and to make appropriations for said purposes.

Discussion: Council Member Tabernik noted that Tonya Crosby, CFO of the Beaufort County School District, was present in the audience.

Council Member Cunningham asked whether and Chairman Passiment confirmed that the millage rate would be lower.

The Vote - The motion was approved without objection.

7. EXECUTIVE SESSION

PURSUANT TO S.C. CODE SECTION 30-4-70(A)(1) DISCUSSION OF EMPLOYMENT OF A PERSON REGULATED BY COUNTY COUNCIL (JOHN ROBINSON)

PURSUANT TO S.C. CODE SECTION 30-4-70(A)(2) TO RECEIVE LEGAL ADVICE ON MATTERS COVERED BY THE ATTORNEY-CLIENT PRIVILEGE (RETENTION OF OUTSIDE LAW FIRM TO CONDUCT REVIEWS AND AUDITS AS PREVIOUSLY APPROVED BY COUNCIL)

PURSUANT TO S. C. CODE SECTION 30-4-70(A)(2) TO RECEIVE LEGAL ADVICE ON MATTERS COVERED BY THE ATTORNEY-CLIENT PRIVILEGE (ERIC GREENWAY'S REQUEST FOR A PUBLIC HEARING PURSUANT TO S. C. CODE SECTION 4-9-620)

Motion: It was moved by Council Member Cunningham, seconded by Council Member Brown, to enter into executive session.

The Vote - The motion was approved without objection.

The executive session started at 4:49 PM and ended at 5:45 PM.

10. MATTERS ARISING OUT OF EXECUTIVE SESSION

Chairman Passiment commented that no items arose from the Executive Session but noted that Eric Greenway had asked for additional time for his public hearing.

11. ADJOURNMENT

Adjourned at or around 5:47 PM

COUNTY COUNCIL OF BEAUFORT COUNTY

BY: _____
Joseph F. Passiment, Jr., Chairman

ATTEST:

Sarah W. Brock, Clerk to Council
Ratified:



Special Called Meeting of County Council Beaufort County, SC

Council Chambers, Administration Building Beaufort County Government Robert Smalls
Complex 100 Ribaut Road, Beaufort

Thursday, August 24, 2023
11:00 AM

MINUTES

Watch the video stream available on the County's website to hear the Council's discussion of a specific topic or the complete meeting. <https://beaufortcountysc.new.swagit.com/videos/270101>

1. CALL TO ORDER

Chairman Passiment called the meeting to order at 11:00 AM.

PRESENT

Chairman Joseph F. Passiment
Vice-Chairman Lawrence McElynn
Council Member David P. Bartholomew
Council Member Paula Brown
Council Member Gerald Dawson
Council Member York Glover
Council Member Alice Howard
Council Member Mark Lawson
Council Member Anna Maria Tabernik
Council Member Thomas Reitz

ABSENT

Council Member Logan Cunningham

2. PLEDGE OF ALLEGIANCE

Chairman Passiment led the Pledge of Allegiance.

3. FOIA

Chairman Passiment noted that public notification of this meeting had been published, posted, and distributed in compliance with the South Carolina Freedom of Information Act.

4. APPROVAL OF AGENDA

Motion: It was moved by Council Member Dawson, seconded by Vice-Chairman McElynn, to approve the agenda.

The Vote - The motion was approved without objection.

5. CITIZEN COMMENT PERIOD

No citizen comments.

6. EXECUTIVE SESSION

PURSUANT TO S.C. CODE SECTION 30-4-70(A)(2) TO ENGAGE IN DISCUSSIONS AND NEGOTIATIONS INCIDENT TO PROPOSED CONTRACTUAL ARRANGEMENTS

Motion: It was moved by Council Member Tabernik, seconded by Council Member Howard, to enter into executive session.

The Vote - The motion was approved without objection.

The Council entered an executive session at 11:03 AM.

7. MATTERS ARISING OUT OF EXECUTIVE SESSION

There were no matters arising out of executive session.

8. ADJOURNMENT

Adjourned: 1:09 PM

COUNTY COUNCIL OF BEAUFORT COUNTY

BY: _____
Joseph F. Passiment, Jr., Chairman

ATTEST:

Sarah W. Brock, Clerk to Council
Ratified:



Special Called Meeting of County Council Beaufort County, SC

Council Chambers, Administration Building Beaufort County Government Robert Smalls
Complex 100 Ribaut Road, Beaufort

Monday, August 28, 2023
11:00 AM

MINUTES

Watch the video stream available on the County's website to hear the Council's discussion of a specific topic or the complete meeting. <https://beaufortcountysc.new.swagit.com/videos/270210>

1. CALL TO ORDER

Chairman Passiment called the meeting to order at 11:00 AM.

PRESENT

Chairman Joseph F. Passiment
Council Member David P. Bartholomew
Council Member Paula Brown
Council Member Gerald Dawson
Council Member York Glover
Council Member Alice Howard
Council Member Mark Lawson (arrived late)
Council Member Anna Maria Tabernik
Council Member Thomas Reitz

ABSENT

Vice-Chairman Lawrence McElynn
Council Member Logan Cunningham

2. PLEDGE OF ALLEGIANCE

Chairman Passiment led the Pledge of Allegiance.

3. FOIA

Chairman Passiment noted that public notification of this meeting had been published, posted, and distributed in compliance with the South Carolina Freedom of Information Act.

4. APPROVAL OF AGENDA

Motion: It was moved by Council Member Tabernik, seconded by Council Member Brown, to approve the agenda.

The Vote - The motion was approved without objection.

5. CITIZEN COMMENTS

Please watch the video stream available on the County’s website to view the full comment.

<https://beaufortcountysc.new.swagit.com/videos/270210?ts=102>

- 1. Skip Hogland

6. EXECUTIVE SESSION

PURSUANT TO S.C. CODE SECTION 30-4-70(A)(2) TO ENGAGE IN DISCUSSIONS AND NEGOTIATIONS INCIDENT TO PROPOSED CONTRACTUAL ARRANGEMENTS

Motion: It was moved by Council Member Glover, seconded by Council Member Howard, to enter into an executive session.

The Vote - The motion was approved without objection.

The Council entered into an executive session from 11:06 AM to 12:42 PM.

7. MATTERS ARISING OUT OF EXECUTIVE SESSION

Please watch the video stream available on the County’s website to view the full discussion.

<https://beaufortcountysc.new.swagit.com/videos/270210?ts=372>

Chairman Passiment commented that two firms had been interviewed by the County Council. Chairman Passiment and Council Member Glover explained the reasons they preferred Firm A. Council Members Reitz, Howard, Brown, Bartholomew, Tabernik, and Lawson explained the reasons they preferred Firm B.

8. ADJOURNMENT

Adjourned: 12:50 PM

COUNTY COUNCIL OF BEAUFORT COUNTY

BY: _____
Joseph F. Passiment, Jr., Chairman

ATTEST:

Sarah W. Brock, Clerk to Council
Ratified:



Special Called Meeting of County Council Beaufort County, SC

Council Chambers, Administration Building Beaufort County Government Robert Smalls
Complex 100 Ribaut Road, Beaufort

Monday, August 28, 2023
3:30 PM

MINUTES

Watch the video stream available on the County's website to hear the Council's discussion of a specific topic or the complete meeting. <https://beaufortcountysc.new.swagit.com/videos/272317>

1. CALL TO ORDER

Chairman Passiment called the meeting to order at 3:30 PM.

PRESENT

Chairman Joseph F. Passiment
Council Member David P. Bartholomew
Council Member Paula Brown
Council Member Logan Cunningham
Council Member Gerald Dawson
Council Member York Glover
Council Member Alice Howard
Council Member Mark Lawson
Council Member Anna Maria Tabernik
Council Member Thomas Reitz

ABSENT

Vice-Chairman Lawrence McElynn

2. PLEDGE OF ALLEGIANCE

Chairman Passiment led the Pledge of Allegiance.

3. FOIA

Chairman Passiment noted that public notification of this meeting had been published, posted, and distributed in compliance with the South Carolina Freedom of Information Act.

4. APPROVAL OF AGENDA

Motion to Amend: It was moved by Council Member Cunningham, seconded by Council Member Tabernik, to remove item #7 from the executive session to be included in the public hearing and action items.

Main Motion: It was moved by Council Member Cunningham, seconded by Council Member Tabernik, to approve the amended agenda.

The Vote - The motions were approved without objection.

5. CITIZEN COMMENT PERIOD

Please watch the video stream available on the County's website to view the full comment.

<https://beaufortcountysc.new.swagit.com/videos/272317?ts=125>

1. Robert New
2. Skip Hoagland

6. PUBLIC HEARING AND THIRD READING OF AN ORDINANCE AMENDMENT TO PROVIDE FOR A MODIFIED MILLAGE RATE FOR THE LEVY OF TAX FOR SCHOOL PURPOSES FOR BEAUFORT COUNTY FOR THE FISCAL YEAR BEGINNING JULY 1, 2023, AND ENDING JUNE 30, 2024, AND TO MAKE APPROPRIATIONS FOR SAID PURPOSES

Please watch the video stream available on the County's website to view the full discussion.

<https://beaufortcountysc.new.swagit.com/videos/272317?ts=626>

Motion: It was moved by Council Member Tabernik, seconded by Council Member Howard, to approve the public hearing and third reading of an ordinance amendment to provide for a modified millage rate for the levy of tax for school purposes for Beaufort County for the fiscal year beginning July 1, 2023, and ending June 30, 2023, and to make appropriations for said purposes.

Chairman Passiment opened the floor for public comment.

1. Skip Hoagland

Chairman Passiment closed the public comment period.

The Vote - The motion was approved without objection.

7. PURSUANT TO S.C. CODE SECTION 30-04-70(A)(2) DISCUSSIONS OF NEGOTIATIONS INCIDENT TO PROPOSED CONTRACTUAL ARRANGEMENTS (RETENTION OF OUTSIDE LAW FIRM TO CONDUCT REVIEWS AND AUDITS AS PREVIOUSLY APPROVED BY COUNCIL)

Motion: It was moved by Council Member Tabernik, seconded by Council Member Bartholomew, to accept and ratify the decision and recommendation of the Finance Committee to hire Law Firm B to perform the reviews and audit we authorized on July 24, 2023, and to perform any additional work that the Committee authorizes the Firm to perform.

The Vote - The motion was approved without objection.

Chairman Passiment shared that Law Firm B was Haynsworth Sinkler Boyd.

Motion: It was moved by Council Member Bartholomew, seconded by Council Member Tabernik, to adopt, by title only, an ordinance amending the FY24 Budget Ordinance (Ordinance 2023/22) to appropriate \$350,000 to Council's budget to cover the anticipated costs of performing the reviews and audit we authorized on July 24, 2023, and any additional work the Finance Committee authorizes it to perform.

The Vote - The motion was approved without objection.

8. EXECUTIVE SESSION

PURSUANT TO S.C. CODE SECTION 30-4-70(A)(1) DISCUSSION OF EMPLOYMENT OF A PERSON REGULATED BY COUNTY COUNCIL (JOHN ROBINSON)

PURSUANT TO S.C. CODE SECTION 30-4-70(A)(2) TO RECEIVE LEGAL ADVICE ON MATTERS COVERED BY THE ATTORNEY-CLIENT PRIVILEGE (ERIC GREENWAY)

Motion: It was moved by Council Member Cunningham, seconded by Council Member Brown, to enter into executive session.

The Vote - The motion was approved without objection.

The Council entered an executive session from 3:47 PM to 4:12 PM.

10. MATTERS ARISING OUT OF EXECUTIVE SESSION

Motion: It was moved by Council Member Brown, seconded by Council Member Howard, to approve the employment agreement for Interim County Administrator John Robinson, as discussed in the executive session.

The Vote - The motion was approved without objection.

11. ADJOURNMENT

Adjourned at or around 4:15 PM

COUNTY COUNCIL OF BEAUFORT COUNTY

BY: _____
Joseph F. Passiment, Jr., Chairman

ATTEST:

Sarah W. Brock, Clerk to Council
Ratified:

~ Proclamation ~

Whereas, bullying is a pervasive issue that affects the well-being and development of our students, leading to negative consequences such as diminished self-esteem, academic decline, emotional distress; and

Whereas, the Beaufort County School District, the Rotary Club of the Lowcountry, and the Beaufort County Council recognize the importance of fostering safe and nurturing learning environments that promote kindness and respect amongst our students; and

Whereas, October has been designated as National Bullying Prevention Month, providing an opportunity for communities across the nation to unite in raising awareness about bullying prevention and empowering individuals to take a stand against such harmful behaviors; and

Whereas, it is essential to collaborate with organizations committed to the welfare of our community, such as the Rotary Club of the Lowcountry, to combine efforts and resources in creating a comprehensive and impactful bullying prevention campaign; and

Whereas, the Beaufort County School District has demonstrated dedication to addressing bullying through the implementation of proactive administrative regulations, educational initiatives, and supportive programs aimed at fostering a culture of kindness, respect, and compassion within our schools; and

Whereas, since 2012, the Rotary Club of the Lowcountry and the Beaufort County School District have successfully collaborated to combat bullying by engaging sixth graders in a bullying prevention educational program; and

Whereas, over 7,082 sixth graders have participated in this educational program to date, and in addition to the program, a See Something Say Something App was developed to facilitate education, report bullying, and provide additional resources advocating for youth development and supporting initiatives that promote positive change.

Now, therefore be it resolved, Beaufort County Council joins advocates and supports service programs in the belief that all community members must be part of the solution to end bullying. Along with the Rotary Club of the Lowcountry and Beaufort County School District, we proclaim October as

“Bullying Prevention Awareness Month”

Dated this 9th Day of October 2023



Joseph F. Passiment, Chairman
Beaufort County Council

CITIZEN COMMENTS 1st PORTION

COUNTY COUNCIL AGENDA ITEMS ONLY

October 9, 2023

CITIZEN COMMENT PERIOD- 15 MINUTES TOTAL

Anyone who wishes to speak during the Citizen Comment portion of the meeting will limit their comments and speak no longer than three (3) minutes. Speakers will address Council in a respectful manner appropriate to the decorum of the meeting, refraining from the use of profane, abusive, or obscene language.

In accordance with Beaufort County's Rules and Procedures, page 7(D4): 1) Each speaker is limited to three minutes 2) Only one speaker limit at microphone, and 3) Giving of a speaker's time is not allowed.

BY SIGNING UP FOR PUBLIC COMMENT, YOU ACKNOWLEDGE THE ABOVE RULES AND WILL COMPLY.

FULL NAME (PLEASE PRINT LEGIBLY)	Topic
Robert New ✓	# 11 34 Elmer
Roberts Vany	# 11

CITIZEN COMMENTS 2nd PORTION

COUNTY COUNCIL

October 9, 2023

CITIZEN COMMENT PERIOD- 15 MINUTES TOTAL

Anyone who wishes to speak during the Citizen Comment portion of the meeting will limit their comments and speak no longer than three (3) minutes. Speakers will address Council in a respectful manner appropriate to the decorum of the meeting, refraining from the use of profane, abusive, or obscene language.

In accordance with Beaufort County's Rules and Procedures, page 7(D4): 1) Each speaker is limited to three minutes 2) Only one speaker limit at microphone, and 3) Giving of a speaker's time is not allowed.

BY SIGNING UP FOR PUBLIC COMMENT, YOU ACKNOWLEDGE THE ABOVE RULES AND WILL COMPLY.

FULL NAME (PLEASE PRINT LEGIBLY)

Topic

Julie Ann Kobus

Yvonna Wilson

Debra McIntyre

Arnold L. Brown

Prospect Rd.

Prospect Rd.

Ferry

CPO- PINE IS

Pine Island Mercenary Groups

Thank you again for upholding the zoning language and intent of the April 1999 CPO and not violating the SPOT Zoning laws of South Carolina. It was an outstanding decision.

1. Housing Keeping

A. The current support petition count is: 12,578 _____

Penn Center petition is over 7007

B. Ms. Gardenia White Face Book viewed is 145,621

Views and like. Share over 4000 times, 5000 followers

2. Penn Center board of directors is 110% in support of the

1999 CPO and protecting owners' properties.

3. Has member of the council heard of a company called Black Water. **Blackwater**, is an American private military contractor founded on December 26, 1996, by former Navy SEAL officer Erik Prince. Hired by the United States / CIA to fight in the Middle East.

4. Wagner Group is a private Mercenary Group hired by Russian to fight in the Ukraine

5. Oliver group

Many of us who support the 1999 CPO believe Mr. Elvio Tropeano has purchased the support of the newly established **Community Coalition Action Network** to support LVO's dreams of a golf course and a gated community on Pine Island.

The Community Coalition Action Network (Mr. Roy Brown, Ms. Theresa White & LVO) has slogans which state **"The Truth Matters" and "Understand The Truth"**.

If they are all about telling the **TRUTH** to the community, then why are they using the Beaufort County logo on hundreds of flyers they have distributed on St. Helena Island?

How is it possible to trust an organization or persons who use Beaufort County logo without authorization and make false promises to give millions of dollars to non-profits organizations?

**Thank you,
Arnold L. Brown, Property Owner
In God We Trust**

Mercenary, hired professional soldier who fights for any state or nation without regard to **political interests or issues**. From the earliest days of organized warfare until the development of political standing armies in the mid-17th century, governments.



BEAUFORT COUNTY COUNCIL AGENDA ITEM SUMMARY

ITEM TITLE:
AN ORDINANCE AUTHORIZING THE COUNTY ADMINISTRATOR TO EXECUTE THE NECESSARY DOCUMENTS AND PROVIDE FUNDING FOR THE PURCHASE OF REAL PROPERTY IDENTIFIED AS 34 ULMER ROAD
MEETING NAME AND DATE:
County Council; August 14, 2023
PRESENTER INFORMATION:
Brittany Ward, County Attorney <i>5 Minutes</i>
ITEM BACKGROUND:
<i>County Council Vote at First Reading on July 10, 2023 – 11:0</i>
PROJECT / ITEM NARRATIVE:
<p>Beaufort County (“County”) desired to purchase the real property located at 34 Ulmer Road, Bluffton, South Carolina, identified as TMS No. R600 039 00B 0038 0000, consisting of approximately 41 acres (“Property”). In May 2019 the County purchased the real property located at 75 Confederate Avenue through the Rural and Critical Lands Program in order to construct a passive park, which is located adjacent to the Property. The County desired to purchase the Property and create a combined active and passive park facility.</p> <p>County staff was aware of a satellite/cell phone tower (“Tower”) on the property and was under the belief there was a remaining two (2) years on said lease. Staff has obtained a survey showing the location of the Tower on the property with guide wire easements that expand over a significant portion of the property. Staff was informed after the First Reading that the real property where the Tower is located is owned by the previous property owner. The location of this Tower is not desirable and limits the ability to have the desired number of active fields on the property.</p>
FISCAL IMPACT:
\$3,150,000 Purchase Price plus closing costs and to include all due diligence costs. Funding source is the General Fund- Fund Balance
STAFF RECOMMENDATIONS TO COUNCIL:
Disapprove due to additional knowledge received by seller regarding a satellite/cell phone tower located on the property which does not allow for the number of active park fields desired.
OPTIONS FOR COUNCIL MOTION:
Move forward to Third Reading on September 11, 2023. Postpone the Third Reading to September 28, 2023 in order to obtain additional information through due diligence. Disapprove.

ORDINANCE 2023/_____

AN ORDINANCE AUTHORIZING THE COUNTY ADMINISTRATOR TO EXECUTE THE NECESSARY DOCUMENTS AND PROVIDE FUNDING FOR THE PURCHASE OF REAL PROPERTY IDENTIFIED AS 34 ULMER ROAD

WHEREAS, Beaufort County (“County”) desires to purchase the real property located at 34 Ulmer Road, Bluffton, South Carolina, identified as TMS No. R600 039 00B 0038 0000, consisting of approximately 41 acres and further described in Exhibit “A” attached hereto and incorporated herein by reference, collectively hereinafter referred to as the “Property”; and

WHEREAS, the County recognizes that there is a need to provide the citizens and residents of Beaufort County with additional active parks and open spaces to enjoy outdoor activities. In an effort to protect the environment and provide a space for citizens to enjoy outdoor activities, in May 2019 the County purchased the real property located at 75 Confederate Avenue through the Rural and Critical Lands Program in order to construct a passive park, which is located adjacent to the Property. For the benefit of its citizens, the County desires to purchase the Property and create a combined active and passive park; and

WHEREAS, the County has negotiated with the seller and agreed upon a fair market value purchase price not to exceed Three Million One Hundred and Fifty (\$3,150,000) Dollars plus closing costs, whereby said purchase price includes the cost of any and all due diligence, including but not limited to, environmental reports and surveys that is to be provided by the seller. Funding for the purchase price and closing costs to be allocated from General Fund-Fund Balance; and

WHEREAS, Beaufort County Council finds that it is in the best interest of the citizens and residents of Beaufort County to purchase the Property as described above.

NOW, THEREFORE, BE IT ORDAINED by Beaufort County Council, duly assembled, authorizing the County Administrator to execute the necessary documents and provide funding in an amount not to exceed Three Million One Hundred and Fifty (\$3,150,000) Dollars plus closing costs from impact fees for the purchase of real property identified as 34 Ulmer Road.

DONE this ____ day of _____ 2023.

COUNTY COUNCIL OF BEAUFORT COUNTY

BY: _____
Joseph Passiment, Chairman

ATTEST:

Sarah W. Brock, Clerk to Council

EXHIBIT A

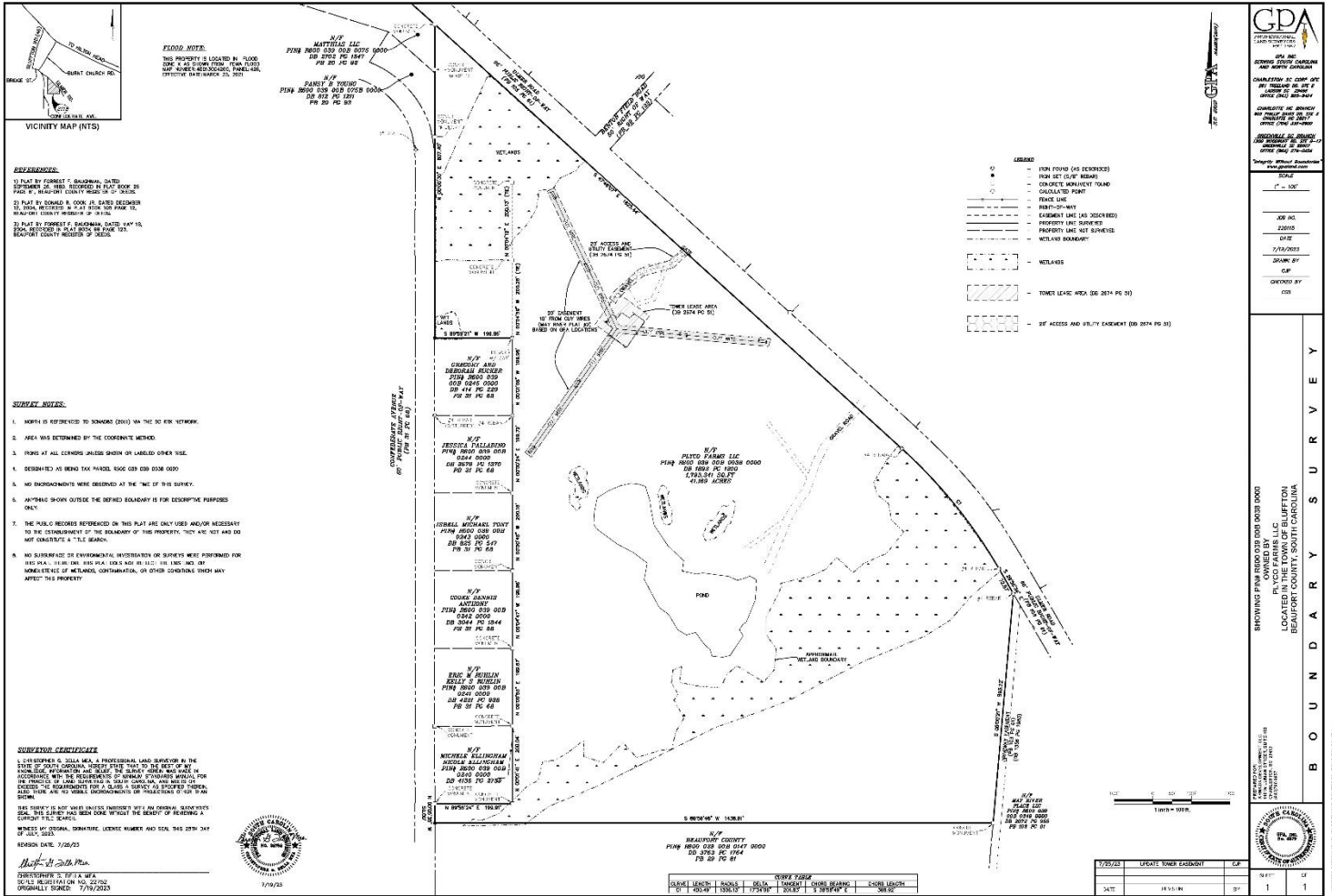

DATE: 7/25/23
JOB NO: 20215
SCALE: AS SHOWN
DRAWN BY: CJP
CHECKED BY: CJB

BOUNDARY SURVEY

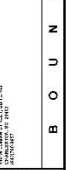

Table with columns: DATE, LOCATE, TOWER EASEMENT, CP



BEAUFORT COUNTY COUNCIL AGENDA ITEM SUMMARY

ITEM TITLE:
RECOMMENDATION OF APPROVAL OF: AN ORDINANCE AUTHORIZING THE HILTON HEAD NO. 1 PUBLIC SERVICE DISTRICT, SOUTH CAROLINA TO ISSUE NOT EXCEEDING \$23,000,000 OF GENERAL OBLIGATION BONDS; AND PROVIDING FOR OTHER MATTERS RELATED THERETO.
MEETING NAME AND DATE:
Finance, Administration, and Economic Development Committee 8/21/2023
PRESENTER INFORMATION:
Pope Flynn, LLC 15 minutes
ITEM BACKGROUND:
The Hilton Head No.1 Public Service District Commission has determined to seek authorization from the Beaufort County Council to issue general obligation bonds. The Commission requests that, following a public hearing on the matter, the County Council enact the ordinance authorizing the issuance of the bonds. This ordinance authorizing the bond issuance is required pursuant to S.C. Code Section 6-11-860.
PROJECT / ITEM NARRATIVE:
<p>The Hilton Head No.1 Public Service District (HHPSD) has determined to issue bonds to defray the costs of: (i) improvements and/or repairs to the wastewater system, including (A) replacement of three screw pumps, (B) the purchase of on-site chemical generation equipment, (C) upgrades to the lift stations, including tank, pump and site upgrades, (D) construction of a sludge building and warehouse building, and (E) the construction of back-up to the band screen, and (ii) improvements and/or repairs to the waterworks system, including (A) the construction of an aquifer storage and recovery system and expansion of the District’s reverse osmosis (“RO”) plant, (B) purchase of on-site chemical generation equipment, (C) purchase of a generator for the RO plant; and (D) acquiring additional wholesale water capacity from Beaufort-Jasper Water and Sewer Authority, (iii) design and engineering costs related to the U.S. Highway 278 bridge relocation project, and (iv) other general improvements, repairs and expansion to the District’s water and sewer system.</p> <p>By way of additional background, some portions of the Project are related to the District’s planned grant funding from South Carolina Rural Infrastructure Administration as part of the South Carolina Infrastructure Improvement Program (SCIIP). Bond funds will be used to make the District’s required grant match.</p>
FISCAL IMPACT:
Limited millage impact is expected in connection with the bonds. The District anticipates structuring new debt service taking into account existing debt service, which, after taking into account the amortization of existing obligations, is not expected to result in a significant millage increase. Additionally, the District may pay some or all of the excess debt service from the revenues of its combined water and sewer utility system. However, the District, acting through the duly elected members of the Hilton Head No.1 Public Service District Commission, reserves the right to levy additional debt service millage as necessary to fund any required debt payments associated with the bonds.

STAFF RECOMMENDATIONS TO COUNCIL:

Recommend approval

OPTIONS FOR COUNCIL MOTION:

Motion to approve/deny "RECOMMENDATION OF APPROVAL OF: AN ORDINANCE AUTHORIZING THE HILTON HEAD NO. 1 PUBLIC SERVICE DISTRICT, SOUTH CAROLINA TO ISSUE NOT EXCEEDING \$23,000,000 OF GENERAL OBLIGATION BONDS; AND PROVIDING FOR OTHER MATTERS RELATED THERETO"

AN ORDINANCE AUTHORIZING THE HILTON HEAD NO. 1 PUBLIC SERVICE DISTRICT, SOUTH CAROLINA TO ISSUE NOT EXCEEDING \$23,000,000 OF GENERAL OBLIGATION BONDS; AND PROVIDING FOR OTHER MATTERS RELATED THERETO

AUTHORIZING ORDINANCE

~~September 25~~October 9, 2023

BE IT ORDAINED BY THE COUNTY COUNCIL OF BEAUFORT COUNTY, SOUTH CAROLINA, AS FOLLOWS:

ARTICLE I – FINDINGS

Section 1.01 Findings of Fact.

The County Council of Beaufort County (the “**County Council**”), the governing body of Beaufort County, South Carolina (the “**County**”), hereby finds and determines:

(a) Article X, Section 14 of the Constitution of the State of South Carolina, 1895, as amended (the “**Constitution**”), provides that special purpose districts may incur general obligation bonded indebtedness upon such terms and conditions as the General Assembly may prescribe by general law, subject to the following limitations: (i) such debt must be incurred only for a purpose which is a public purpose and a corporate purpose, and (ii) unless excepted therefrom, such debt may be issued in an amount not exceeding 8% of the assessed value of all taxable property of such special purpose district (the “**Bonded Debt Limit**”).

(b) Pursuant to Title 6, Chapter 11, Article 5 of the Code of Laws of South Carolina 1976, as amended (the “**Enabling Act**”), the governing body of any county in the State of South Carolina (the “**State**”) may authorize the issuance of general obligation bonds by special purpose districts located within its bounds to defray the cost of any authorized purpose and for any amount not exceeding such special purpose district’s applicable Bonded Debt Limit..

(c) Hilton Head No. 1 Public Service District, South Carolina (the “**District**”) was created and established as a special purpose district, a body politic and corporate, pursuant to the provisions of Act No. 569 of the Acts and Joint Resolutions of the General Assembly of the State of South Carolina for the year 1969, as amended. The District is located wholly within the County and is authorized, *inter alia*, (i) to provide water and sewer services, (ii) to acquire, purchase, hold, use, lease, mortgage, sell, transfer and dispose of any property, real, personal, or mixed, or any interest therein, and (iii) to do all other acts and things necessary or convenient to carry out any function or power committed or granted to the District.

(d) Pursuant to Section 6-11-830 of the Enabling Act, the County Council, upon petition of the governing body of any special purpose district, may determine that it is in the interest of such special purpose district to raise moneys for the furtherance of any power or function of the special purpose district and order a public hearing to be held upon the question of the issuance of general obligation bonds of the District.

(e) The County is in receipt of a petition from the Hilton Head No. 1 Public Service District Commission (the “**Commission**”), the governing body of District, requesting authorization to issue not exceeding \$23,000,000 of general obligation bonds (the “**Bonds**”) in order to (1) defray the costs of (i) improvements and/or repairs to the wastewater system, including (A) replacement of three screw pumps, (B) the purchase of on-site chemical generation equipment, (C) upgrades to the lift stations, including tank, pump and site upgrades, (D) construction of a sludge building and warehouse building, and (E) the construction of back-up to

the band screen, and (ii) improvements and/or repairs to the waterworks system, including (A) the construction of an aquifer storage and recovery system and expansion of the District's reverse osmosis ("**RO**") plant, (B) purchase of on-site chemical generation equipment, (C) purchase of a generator for the RO plant; and (D) acquiring additional wholesale water capacity from Beaufort-Jasper Water and Sewer Authority, (iii) design and engineering costs related to the U.S. Highway 278 bridge relocation project, and (iv) other general improvements, repairs and expansion to the District's water and sewer system (collectively, to the extent financed with proceeds of the Bonds, the "**Project**"), and (2) pay the costs of issuance of the Bonds.

(f) The Bond proceeds will also provide the requisite matching funds to permit the District to receive approximately \$10,000,000 in grant funding (the "**SCIIP Grant**") from the South Carolina Rural Infrastructure Administration under the South Carolina Infrastructure Improvement Program. The proceeds of the SCIIP Grant will be used by the District to finance additional improvements to the District's wastewater system related to the Project.

(g) By action previously taken, the County Council ordered that a public hearing (the "**Public Hearing**") on the question of the issuance of the Bonds be held on ~~September 25~~[October 9](#), 2023, at 5:00 p.m., and the notice of the Public Hearing was duly published once a week for three successive weeks in *The Beaufort Gazette* and *Island Packet*, newspapers of general circulation in the County.

(h) The Public Hearing has been duly held at the time and date and in the manner set forth above and was conducted publicly. Both proponents and opponents of the proposed action were given full opportunity to be heard and it is now in order for the County Council to proceed, after due deliberation, in accordance with the provisions of the Enabling Act to make a finding as to whether or not the Bonds should be issued.

(i) The County Council finds that it is in the interest of the District to authorize and provide for the issuance and sale of the Bonds of the District pursuant to the aforesaid provisions of the Constitution and laws of the State for the purposes of providing funds for the Project and providing for the costs of issuance of the Bonds.

ARTICLE II – AUTHORIZATIONS

Section 2.01 Authorizations.

(a) It is found and determined that each statement of fact set forth in the preamble of this ordinance (this "**Ordinance**") is in all respects true and correct.

(b) On the basis of the facts adduced at the Public Hearing, it is found and determined that the Commission is authorized to issue the Bonds.

(c) The County Council finds that the Commission should issue the Bonds in the amount of not exceeding \$23,000,000 as a single issue or from time to time as several separate issues, as the the Commission, in its sole discretion, shall determine. The issuance of the Bonds

is not conditioned upon the holding of a special election and no further action or authorization of the County shall be required as a condition for the issuance of the Bonds.

(d) Notice of the enactment of this Ordinance, as required by Section 6-11-870 of the Enabling Act and in substantially similar form to that attached hereto as Exhibit A, shall be published in both the *Beaufort Gazette* and *Island Packet* for three successive weeks. Such notice, upon the first publication thereof, shall also constitute proper notice of action as authorized by Section 11-27-40(8) of the Code of Law of South Carolina 1976, as amended.

Section 2.02 Ordinance to be Provided to District.

A certified copy of this Ordinance shall forthwith be transmitted to the Commission to advise it of the action taken by the County Council, whereby the Commission has been authorized to issue, pursuant to the provisions of the Enabling Act, the Bonds in the aggregate principal amount of not exceeding \$23,000,000.

Section 2.03 Further Action.

The Chairman and other County officers are herewith authorized and empowered to take such further action as may be necessary to fully implement the action contemplated by this Ordinance.

[Remainder of Page Intentionally Blank]

DONE AT BEAUFORT COUNTY, SOUTH CAROLINA, this ~~25th~~9th day of ~~September~~
October 2023.

COUNTY COUNCIL OF BEAUFORT COUNTY

(SEAL)

Joe Passiment, Chairman

Attest:

Sarah W. Brock, Clerk
County Council of Beaufort County

First Reading: ~~August 28~~September 11, 2023
Second Reading: September ~~11~~25, 2023
Public Hearing: ~~September 25~~October 9, 2023
Third Reading: ~~September 25~~October 9, 2023

EXHIBIT A

NOTICE OF ACTION

Notice is hereby given pursuant to the provisions of Sections 6-11-870 and 11-27-40(8) of the Code of Laws of South Carolina 1976, as amended (together, the “Authorizing Acts”), as follows:

Following a public hearing held ~~September 25~~October 9, 2023, the County Council of Beaufort County (the “County Council”), the governing body of Beaufort County, South Carolina, enacted that certain ordinance, entitled “AN ORDINANCE AUTHORIZING THE HILTON HEAD NO. 1 PUBLIC SERVICE DISTRICT, SOUTH CAROLINA TO ISSUE NOT EXCEEDING \$23,000,000 OF GENERAL OBLIGATION BONDS; AND PROVIDING FOR OTHER MATTERS RELATED THERETO” on ~~September 25~~October 9, 2023 (the “Ordinance”).

Hilton Head No. 1 Public Service District, South Carolina (the “District”), a special purpose district established in Beaufort County, as a body politic and corporate pursuant to the provisions of Act No. 596 of the Acts and Joint Resolutions of the General Assembly of the State of South Carolina for the year 1969, as amended, has been authorized by the provisions of the Ordinance to issue not exceeding \$23,00,000 in aggregate principal amount of general obligation bonds of the District (the “Bonds”) as a single issue or from time to time as several separate issues, in order to (1) defray the costs of (i) improvements and/or repairs to the wastewater system, including (A) replacement of three screw pumps, (B) the purchase of on-site chemical generation equipment, (C) upgrades to the lift stations, including tank, pump and site upgrades, (D) construction of a sludge building and warehouse building, and (E) the construction of back-up to the band screen, and (ii) improvements and/or repairs to the waterworks system, including (A) the construction of an aquifer storage and recovery system and expansion of the District’s reverse osmosis (“RO”) plant, (B) purchase of on-site chemical generation equipment, (C) purchase of a generator for the RO plant; and (D) acquiring additional wholesale water capacity from Beaufort-Jasper Water and Sewer Authority, (iii) design and engineering costs related to the U.S. Highway 278 bridge relocation project, and (iv) other general improvements, repairs and expansion to the District’s water and sewer system, and (2) pay the costs of issuance of the Bonds.

For the payment of the principal of and interest on the Bonds as they respectively mature, and for the creation of such sinking fund as may be necessary therefor, the full faith, credit and taxing power of the District will be irrevocably pledged, and there will be levied annually a tax without limit on all taxable property within the area of the District sufficient to pay the principal of and interest on the Bonds as they respectively mature, and to create such sinking fund therefor.

No election has been ordered in the District upon the question of the issuance of the Bonds.

Any persons affected by the action aforesaid of the County Council may object to the Ordinance and challenge the action of the County Council by following the procedures provided in the Authorizing Acts.

COUNTY COUNCIL OF BEAUFORT COUNTY

AN ORDINANCE AUTHORIZING THE HILTON HEAD NO. 1 PUBLIC SERVICE DISTRICT, SOUTH CAROLINA TO ISSUE NOT EXCEEDING \$23,000,000 OF GENERAL OBLIGATION BONDS; AND PROVIDING FOR OTHER MATTERS RELATED THERETO

AUTHORIZING ORDINANCE

October 9, 2023

**BE IT ORDAINED BY THE COUNTY COUNCIL OF BEAUFORT COUNTY,
SOUTH CAROLINA, AS FOLLOWS:**

ARTICLE I – FINDINGS

Section 1.01 Findings of Fact.

The County Council of Beaufort County (the “*County Council*”), the governing body of Beaufort County, South Carolina (the “*County*”), hereby finds and determines:

(a) Article X, Section 14 of the Constitution of the State of South Carolina, 1895, as amended (the “*Constitution*”), provides that special purpose districts may incur general obligation bonded indebtedness upon such terms and conditions as the General Assembly may prescribe by general law, subject to the following limitations: (i) such debt must be incurred only for a purpose which is a public purpose and a corporate purpose, and (ii) unless excepted therefrom, such debt may be issued in an amount not exceeding 8% of the assessed value of all taxable property of such special purpose district (the “*Bonded Debt Limit*”).

(b) Pursuant to Title 6, Chapter 11, Article 5 of the Code of Laws of South Carolina 1976, as amended (the “*Enabling Act*”), the governing body of any county in the State of South Carolina (the “*State*”) may authorize the issuance of general obligation bonds by special purpose districts located within its bounds to defray the cost of any authorized purpose and for any amount not exceeding such special purpose district’s applicable Bonded Debt Limit..

(c) Hilton Head No. 1 Public Service District, South Carolina (the “*District*”) was created and established as a special purpose district, a body politic and corporate, pursuant to the provisions of Act No. 569 of the Acts and Joint Resolutions of the General Assembly of the State of South Carolina for the year 1969, as amended. The District is located wholly within the County and is authorized, *inter alia*, (i) to provide water and sewer services, (ii) to acquire, purchase, hold, use, lease, mortgage, sell, transfer and dispose of any property, real, personal, or mixed, or any interest therein, and (iii) to do all other acts and things necessary or convenient to carry out any function or power committed or granted to the District.

(d) Pursuant to Section 6-11-830 of the Enabling Act, the County Council, upon petition of the governing body of any special purpose district, may determine that it is in the interest of such special purpose district to raise moneys for the furtherance of any power or function of the special purpose district and order a public hearing to be held upon the question of the issuance of general obligation bonds of the District.

(e) The County is in receipt of a petition from the Hilton Head No. 1 Public Service District Commission (the “*Commission*”), the governing body of District, requesting authorization to issue not exceeding \$23,000,000 of general obligation bonds (the “*Bonds*”) in order to (1) defray the costs of (i) improvements and/or repairs to the wastewater system, including (A) replacement of three screw pumps, (B) the purchase of on-site chemical generation equipment, (C) upgrades to the lift stations, including tank, pump and site upgrades, (D) construction of a sludge building and warehouse building, and (E) the construction of back-up to the band screen, and (ii) improvements

and/or repairs to the waterworks system, including (A) the construction of an aquifer storage and recovery system and expansion of the District’s reverse osmosis (“**RO**”) plant, (B) purchase of on-site chemical generation equipment, (C) purchase of a generator for the RO plant; and (D) acquiring additional wholesale water capacity from Beaufort-Jasper Water and Sewer Authority, (iii) design and engineering costs related to the U.S. Highway 278 bridge relocation project, and (iv) other general improvements, repairs and expansion to the District’s water and sewer system (collectively, to the extent financed with proceeds of the Bonds, the “**Project**”), and (2) pay the costs of issuance of the Bonds.

(f) The Bond proceeds will also provide the requisite matching funds to permit the District to receive approximately \$10,000,000 in grant funding (the “**SCIIP Grant**”) from the South Carolina Rural Infrastructure Administration under the South Carolina Infrastructure Improvement Program. The proceeds of the SCIIP Grant will be used by the District to finance additional improvements to the District’s wastewater system related to the Project.

(g) By action previously taken, the County Council ordered that a public hearing (the “**Public Hearing**”) on the question of the issuance of the Bonds be held on October 9, 2023, at 5:00 p.m., and the notice of the Public Hearing was duly published once a week for three successive weeks in *The Beaufort Gazette* and *Island Packet*, newspapers of general circulation in the County.

(h) The Public Hearing has been duly held at the time and date and in the manner set forth above and was conducted publicly. Both proponents and opponents of the proposed action were given full opportunity to be heard and it is now in order for the County Council to proceed, after due deliberation, in accordance with the provisions of the Enabling Act to make a finding as to whether or not the Bonds should be issued.

(i) The County Council finds that it is in the interest of the District to authorize and provide for the issuance and sale of the Bonds of the District pursuant to the aforesaid provisions of the Constitution and laws of the State for the purposes of providing funds for the Project and providing for the costs of issuance of the Bonds.

ARTICLE II – AUTHORIZATIONS

Section 2.01 Authorizations.

(a) It is found and determined that each statement of fact set forth in the preamble of this ordinance (this “**Ordinance**”) is in all respects true and correct.

(b) On the basis of the facts adduced at the Public Hearing, it is found and determined that the Commission is authorized to issue the Bonds.

(c) The County Council finds that the Commission should issue the Bonds in the amount of not exceeding \$23,000,000 as a single issue or from time to time as several separate issues, as the the Commission, in its sole discretion, shall determine. The issuance of the Bonds is not conditioned upon the holding of a special election and no further action or authorization of the County shall be required as a condition for the issuance of the Bonds.

(d) Notice of the enactment of this Ordinance, as required by Section 6-11-870 of the Enabling Act and in substantially similar form to that attached hereto as Exhibit A, shall be published in both the *Beaufort Gazette* and *Island Packet* for three successive weeks. Such notice, upon the first publication thereof, shall also constitute proper notice of action as authorized by Section 11-27-40(8) of the Code of Law of South Carolina 1976, as amended.

Section 2.02 Ordinance to be Provided to District.

A certified copy of this Ordinance shall forthwith be transmitted to the Commission to advise it of the action taken by the County Council, whereby the Commission has been authorized to issue, pursuant to the provisions of the Enabling Act, the Bonds in the aggregate principal amount of not exceeding \$23,000,000.

Section 2.03 Further Action.

The Chairman and other County officers are herewith authorized and empowered to take such further action as may be necessary to fully implement the action contemplated by this Ordinance.

[Remainder of Page Intentionally Blank]

DONE AT BEAUFORT COUNTY, SOUTH CAROLINA, this 9th day of October 2023.

COUNTY COUNCIL OF BEAUFORT COUNTY

(SEAL)

Joe Passiment, Chairman

Attest:

Sarah W. Brock, Clerk
County Council of Beaufort County

First Reading: September 11, 2023
Second Reading: September 25, 2023
Public Hearing: October 9, 2023
Third Reading: October 9, 2023

EXHIBIT A

NOTICE OF ACTION

Notice is hereby given pursuant to the provisions of Sections 6-11-870 and 11-27-40(8) of the Code of Laws of South Carolina 1976, as amended (together, the “Authorizing Acts”), as follows:

Following a public hearing held October 9, 2023, the County Council of Beaufort County (the “County Council”), the governing body of Beaufort County, South Carolina, enacted that certain ordinance, entitled “AN ORDINANCE AUTHORIZING THE HILTON HEAD NO. 1 PUBLIC SERVICE DISTRICT, SOUTH CAROLINA TO ISSUE NOT EXCEEDING \$23,000,000 OF GENERAL OBLIGATION BONDS; AND PROVIDING FOR OTHER MATTERS RELATED THERETO” on October 9, 2023 (the “Ordinance”).

Hilton Head No. 1 Public Service District, South Carolina (the “District”), a special purpose district established in Beaufort County, as a body politic and corporate pursuant to the provisions of Act No. 596 of the Acts and Joint Resolutions of the General Assembly of the State of South Carolina for the year 1969, as amended, has been authorized by the provisions of the Ordinance to issue not exceeding \$23,00,000 in aggregate principal amount of general obligation bonds of the District (the “Bonds”) as a single issue or from time to time as several separate issues, in order to (1) defray the costs of (i) improvements and/or repairs to the wastewater system, including (A) replacement of three screw pumps, (B) the purchase of on-site chemical generation equipment, (C) upgrades to the lift stations, including tank, pump and site upgrades, (D) construction of a sludge building and warehouse building, and (E) the construction of back-up to the band screen, and (ii) improvements and/or repairs to the waterworks system, including (A) the construction of an aquifer storage and recovery system and expansion of the District’s reverse osmosis (“RO”) plant, (B) purchase of on-site chemical generation equipment, (C) purchase of a generator for the RO plant; and (D) acquiring additional wholesale water capacity from Beaufort-Jasper Water and Sewer Authority, (iii) design and engineering costs related to the U.S. Highway 278 bridge relocation project, and (iv) other general improvements, repairs and expansion to the District’s water and sewer system, and (2) pay the costs of issuance of the Bonds.

For the payment of the principal of and interest on the Bonds as they respectively mature, and for the creation of such sinking fund as may be necessary therefor, the full faith, credit and taxing power of the District will be irrevocably pledged, and there will be levied annually a tax without limit on all taxable property within the area of the District sufficient to pay the principal of and interest on the Bonds as they respectively mature, and to create such sinking fund therefor.

No election has been ordered in the District upon the question of the issuance of the Bonds.

Any persons affected by the action aforesaid of the County Council may object to the Ordinance and challenge the action of the County Council by following the procedures provided in the Authorizing Acts.

COUNTY COUNCIL OF BEAUFORT COUNTY

BOND SITUATION SHEET

Jurisdiction: Hilton Head No.1 Public Service District, South Carolina (the “District”)

Amount of Bonds: Not exceeding \$23,000,000

Type of Bonds: General Obligation (GO)

Purpose: The District is seeking authorization from Beaufort County Council (“County Council”) to issue general obligation bonds (the “Bonds”) to defray all or a portion of the costs of (i) improvements and/or repairs to the wastewater system, including (A) replacement of three screw pumps, (B) the purchase of on-site chemical generation equipment, (C) upgrades to the lift stations, including tank, pump and site upgrades, (D) construction of a sludge building and warehouse building, and (E) the construction of back-up to the band screen, and (ii) improvements and/or repairs to the waterworks system, including (A) the construction of an aquifer storage and recovery system and expansion of the District’s reverse osmosis (“RO”) plant, (B) purchase of on-site chemical generation equipment, (C) purchase of a generator for the RO plant; and (D) acquiring additional wholesale water capacity from Beaufort-Jasper Water and Sewer Authority, (iii) design and engineering costs related to the U.S. Highway 278 bridge relocation project, and (iv) other general improvements, repairs and expansion to the District’s water and sewer system (collectively, to the extent financed with proceeds of the Bonds, the “Project”), and the costs of the Bonds.

By way of additional background, some portions of the Project are related to the District’s planned grant funding from South Carolina Rural Infrastructure Administration as part of the South Carolina Infrastructure Improvement Program (SCIIP). Bond funds will be used to make the District’s required grant match.

Restrictions on Proceeds: All Bond proceeds are restricted to the purposes described above as set forth in the proposed authorizing ordinance.

Impact on Millage: Limited millage impact is expected in connection with the Bonds. The District anticipates structuring new debt service taking into account existing debt service, which, after taking into account the amortization of existing obligations, is not expected to result in a significant millage increase. Additionally, the District may pay some or all of the excess debt service from the revenues of its combined water and sewer utility system. However, the District reserves the

right to levy additional debt service millage as necessary to fund any required debt payments associated with the Bonds.

Procedural Posture: Upon receipt of the petition from the District, the South Carolina Code requires County Council to hold a public hearing on the question of the issuance of the Bonds. Following the hearing, the District requests that County Council enact an ordinance finding whether and to what extent the Bonds should be issued and authorizing the governing body of the District to issue the Bonds.

ACTIONS REQUESTED OF COUNTY COUNCIL

1. Adopt a resolution authorizing a public hearing and notice thereof;
2. Hold a public hearing on the proposed issuance of the Bonds; and
3. Enact an ordinance authorizing the District to issue Bonds in an amount not to exceed \$23,000,000.

RECOMMENDATIONS

1. Consideration by Finance Committee on August 21, 2023
2. Adopt a resolution on September 11, 2023, authorizing a public hearing on October 9, 2023 at 5:00 p.m.
3. County Council to give first reading to the authorizing ordinance on September 11, 2023, second reading on September 25, 2023, and public hearing/third reading on October 9, 2023.

BOND SITUATION SHEET

Jurisdiction: Hilton Head No.1 Public Service District, South Carolina (the “District”)

Amount of Bonds: Not exceeding \$23,000,000

Type of Bonds: General Obligation (GO)

Purpose: The District is seeking authorization from Beaufort County Council (“County Council”) to issue general obligation bonds (the “Bonds”) to defray all or a portion of the costs of (i) improvements and/or repairs to the wastewater system, including (A) replacement of three screw pumps, (B) the purchase of on-site chemical generation equipment, (C) upgrades to the lift stations, including tank, pump and site upgrades, (D) construction of a sludge building and warehouse building, and (E) the construction of back-up to the band screen, and (ii) improvements and/or repairs to the waterworks system, including (A) the construction of an aquifer storage and recovery system and expansion of the District’s reverse osmosis (“RO”) plant, (B) purchase of on-site chemical generation equipment, (C) purchase of a generator for the RO plant; and (D) acquiring additional wholesale water capacity from Beaufort-Jasper Water and Sewer Authority, (iii) design and engineering costs related to the U.S. Highway 278 bridge relocation project, and (iv) other general improvements, repairs and expansion to the District’s water and sewer system (collectively, to the extent financed with proceeds of the Bonds, the “Project”), and the costs of the Bonds.

By way of additional background, some portions of the Project are related to the District’s planned grant funding from South Carolina Rural Infrastructure Administration as part of the South Carolina Infrastructure Improvement Program (SCIIP). Bond funds will be used to make the District’s required grant match.

Restrictions on Proceeds: All Bond proceeds are restricted to the purposes described above as set forth in the proposed authorizing ordinance.

Impact on Millage: Limited millage impact is expected in connection with the Bonds. The District anticipates structuring new debt service taking into account existing debt service, which, after taking into account the amortization of existing obligations, is not expected to result in a significant millage increase. Additionally, the District may pay some or all of the excess debt service from the revenues of its combined water and sewer utility system. However, the District reserves the

right to levy additional debt service millage as necessary to fund any required debt payments associated with the Bonds.

Procedural Posture: Upon receipt of the petition from the District, the South Carolina Code requires County Council to hold a public hearing on the question of the issuance of the Bonds. Following the hearing, the District requests that County Council enact an ordinance finding whether and to what extent the Bonds should be issued and authorizing the governing body of the District to issue the Bonds.

ACTIONS REQUESTED OF COUNTY COUNCIL

1. Adopt a resolution authorizing a public hearing and notice thereof;
2. Hold a public hearing on the proposed issuance of the Bonds; and
3. Enact an ordinance authorizing the District to issue Bonds in an amount not to exceed \$23,000,000.

RECOMMENDATIONS

1. Consideration by Finance Committee on August 21, 2023
2. Adopt a resolution on ~~August 28~~September 11, 2023, authorizing a public hearing on ~~September 25~~October 9, 2023 at 5:00 p.m.
3. County Council to give first reading to the authorizing ordinance on ~~August 28~~September 11, 2023, second reading on September ~~11~~25, 2023, and public hearing/third reading on ~~September 25~~October 9, 2023.



General Obligation Bonds

August 2023



**Water
Production**



**Water
Treatment**



**Water
Distribution**



**Sanitary
Sewer
Collection**



**Wastewater
Treatment**



**Recycled
Water
Distribution**



Hilton Head PSD is a South Carolina special purpose district. It is governed by a seven-member Board of Commissioners. The Commissioners are elected during the general election cycle from voting districts comprising the PSD service area.

S.C. Infrastructure Investment Program (SCIIP) Grant Projects

PSD received a \$10-million SCIIP Grant for two long-term water supply projects:

- Expansion of the PSD's Reverse Osmosis (RO) Drinking Water Treatment Plant capacity
- Construction of a second Aquifer Storage & Recovery (ASR) well

The projects were estimated at \$17 million total in summer '22.

Local match is required to complete the projects.

Need for the S.C. Infrastructure Investment Program (SCIIP) Projects

1

Meet PSD's peak demands for tap water

2

Replace freshwater supply lost to saltwater intrusion

3

Create resiliency of supply for hurricane recovery

4

Protect water supply from PFAS contaminants

5

Lessen peak-season demand on wholesale provider

RO PLANT EXPANSION

- Membrane filtration of brackish groundwater (Middle Floridan Aquifer)
- Expand treatment capacity from 4 mgd to 6 mgd
- Add emergency power generator

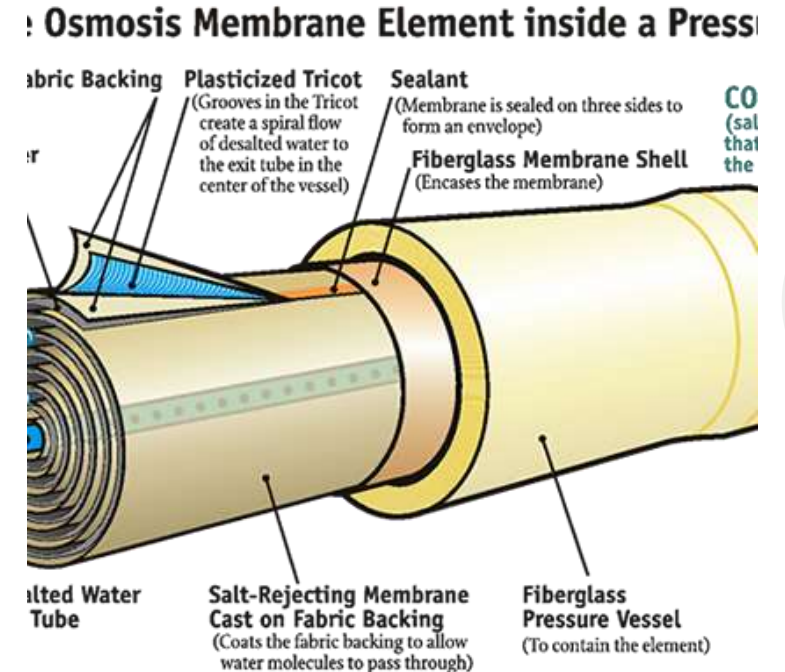

RO Plant Expansion

Construct fourth Middle Floridan Aquifer brackish water production well necessary to add 2 mgd of RO Plant capacity.

Town of HHI providing site at Old Welcome Center parcel.



Aquifer Storage & Recovery (ASR) Well #2

Add a second ASR well for the PSD's water supply system.

Town of HHI providing site at Ashmore Tract.



ASR stores treated drinking water in the brackish aquifer during the winter months of lower demand, and then withdraws and retreats the water for distribution in the summer months of higher demand.

Yields 2 mgd of supply in summer

Key for disaster recovery

ASR Well = 260 mg ↓



Ground Storage Tank = 2 mg



Additional Projects for GO Bonds

- Local funding for wholesale water pipeline relocation due to U.S. 278 Corridor project
- Purchase of additional wholesale water capacity
- Wastewater treatment plant and collection system upgrades

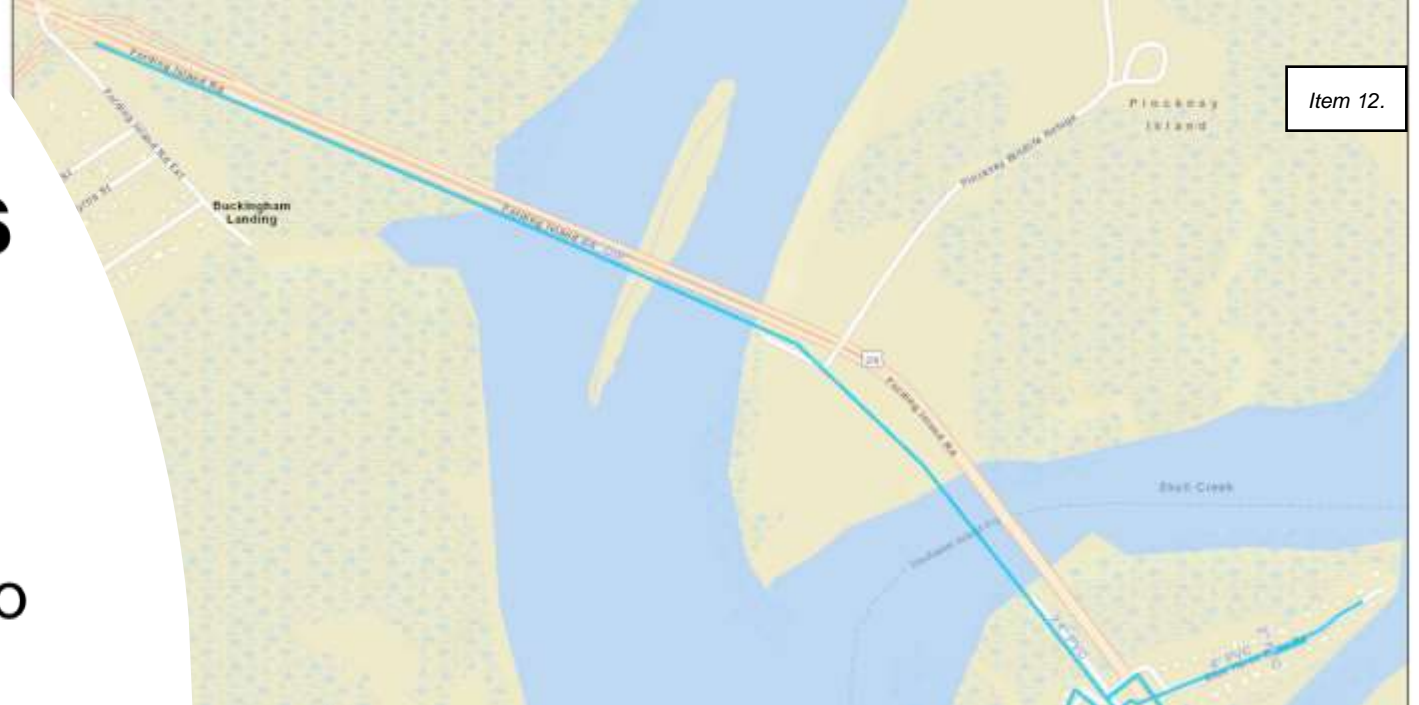

Project Funding

- Limited millage impact is expected in connection with the Bonds. The District anticipates structuring new debt service taking into account existing debt service.
 - Actual FY 2024 PSD total millage: 7.1 (3 mills - Operations; 4.1 mills - Debt)
 - Estimated FY 2025 PSD total millage (including borrowing): 8.1 mills (3 mills - Operations; 5.1 - Debt)
 - Actual FY 2024 PSD taxes on a primary home valued at \$100,000.00 = \$28.40
 - Estimated FY 2025 PSD taxes = \$32.40
-



Thank you

Questions?



BEAUFORT COUNTY COUNCIL AGENDA ITEM SUMMARY

ITEM TITLE:
Proposed Text Amendment to Article 7, Division 7.4, Section 7.4.50 (Public Hearing Scheduling and Notice) and Section 7.4.70 (Public Hearing Procedures) to clarify that public comment is not taken for appeals to the Planning Commission or the Zoning Board of Appeals
MEETING NAME AND DATE:
<i>Community Services and Land Use Committee Meeting, September 11, 2023</i>
PRESENTER INFORMATION:
<i>Robert Merchant, AICP, Director, Beaufort County Planning and Zoning (10 minutes needed for item discussion)</i>
ITEM BACKGROUND:
<i>Both the Planning Commission and the Zoning Board of Appeals (ZBOA) occasionally hear appeals from an aggrieved party affected by a decision made by an administrative decision-maker to determine if the decision complies with the requirements of the Community Development Code (CDC). The reason public comment is not received during an appeal is that the public will introduce opinion testimony that was not part of the decision process. This new information might serve improperly as a basis for a decision and result in the decision being overturned by a circuit court on appeal. The CDC currently is ambiguous regarding the conduct of public hearings for appeals. At their July 6 meeting, the Planning Commission (5-1) recommended approval of the proposed text revisions.</i>
PROJECT / ITEM NARRATIVE:
<i>Staff is proposing changes to the following Community Development Code (CDC) Sections to clarify that public comment is not taken for appeals to the Planning Commission or the Zoning Board of Appeals:</i> <ul style="list-style-type: none">• 7.4.50- Public Hearing Scheduling and Notice• 7.4.70- Public Hearing Procedures
FISCAL IMPACT:
<i>Not applicable</i>
STAFF RECOMMENDATIONS TO COUNCIL:
<i>Staff recommends approval.</i>
OPTIONS FOR COUNCIL MOTION:
<i>To approve or deny the proposed text amendments to the Community Development Code (CDC)</i>

ORDINANCE 2023/_____

PROPOSED TEXT AMENDMENT TO ARTICLE 7, DIVISION 7.4, SECTION 7.4.50 (PUBLIC HEARING SCHEDULING AND NOTICE) AND SECTION 7.4.70 (PUBLIC HEARING PROCEDURES) TO CLARIFY THAT PUBLIC COMMENT IS NOT TAKEN FOR APPEALS TO THE PLANNING COMMISSION OR THE ZONING BOARD OF APPEALS

WHEREAS, both the Planning Commission and the Zoning Board of Appeals (ZBOA) occasionally hear appeals from an aggrieved party affected by a decision made by an administrative decision-maker to determine if the decision complies with the requirements of the Community Development Code (CDC); and

WHEREAS, when the Planning Commission or ZBOA hears an appeal, they follow a “quasi-judicial” process where they are given the powers and procedures resembling those of a court of law where which are obliged to determine facts objectively based on the file and the record that the decision maker relied upon; and

WHEREAS, new information might serve improperly as a basis for a decision and result in the decision being overturned by a circuit court on appeal; and

WHEREAS, the CDC currently is ambiguous regarding the conduct of public hearings for appeals; and

WHEREAS, the Beaufort County Planning Commission considered the proposed text amendments at their July 6, 2023 meeting, voting to recommend that County Council approve the proposed amendments.

NOW, THEREFORE be it ordained by County Council in a meeting duly assembled that Sections 7.4.50 (Public Hearing Scheduling and Notice) and 7.4.70 (Public Hearing Procedures) of the Community Development Code are hereby amended as set forth in Exhibit A hereto. Additions are highlighted and underlined.

Adopted this _____ day of _____ 2023.

COUNTY COUNCIL OF BEAUFORT COUNTY

By: _____
Joseph Passiment, Chairman

ATTEST:

Sarah W. Brock, JD, Clerk to Council

7.4.50 - Public Hearing Scheduling and Notice

A. Public Hearing Scheduling.

1. **Application to be Scheduled for Meeting.** When a development application is subject to a public hearing, as identified in Table 7.4.50.A (Required Public Hearings), the Director shall ensure that the public hearing on the application is scheduled for a regularly scheduled meeting or a meeting specially called for that purpose by the advisory or decision-making body reviewing the application.
2. **Timing.** The public hearing(s) on the application shall be scheduled so there is sufficient time for a staff report to be prepared and for the public notification requirements to be satisfied under state law.
3. **Public Hearing by Review Boards.** A public hearing shall be conducted by the following advisory or decision-making bodies for the following development applications. See Table 7.4.50.A (Required Public Hearings).

> Table 7.4.50.A: Required Public Hearings			
Development Application or Approval	Advisory or Decision-Making Bodies		
	County Council	Planning Commission	Zoning Board of Appeals (ZBOA)
Comprehensive Plan Amendment	X	X	
Text Amendment	X	X	
Zone Map Amendment	X	X	
Special Use Permit			X
Variance Permit			X
Street Renaming		X	
Appeal to Planning Commission		X*	
Appeal to Zoning Board of Appeals			X*
Development Agreements	X		

*Public comment is not taken for appeals to the Planning Commission or the Zoning Board of Appeals (7.3.70.C)

- ### B. Public Hearing Notification.
- All development applications requiring a public hearing shall comply with the S.C. Code of Laws, the provisions listed in Table 7.4.50.B (Public Hearing Notification Timing Requirements), and the other provisions of this Section with regard to public notification. Failure to receive notice in accordance with this Section shall not invalidate the proceedings for which notice was required, nor shall failure to receive notice constitute a basis for legal action against the County.

1. **Notice Timing Requirements.** Public notification of a public hearing on a development application shall be provided in accordance with the timing requirements in Table 7.4.50.B (Public Hearing Notification Timing Requirements), for the type of application and the type of notice. In computing the required time periods, the day the notice is published or postmarked shall not be included, but the day of the hearing shall be included.

7.4.70 - Public Hearing Procedures

- A. If the development application is subject to a public hearing by an advisory or decision-making body, the advisory or decision-making body shall hold the public hearing in accordance with the following procedures.
- B. **Conduct of Public Hearing.**
1. **Burden of Proof or Persuasion.** The burden of demonstrating that an application complies with applicable review and approval standards of this Development Code is on the applicant. The burden is not on the County or other parties to show that the standards have not been met by the applicant.
 2. **Rights of All Persons.** Except for appeals to the Planning Commission or the Zoning Board of Appeals (7.3.70.C), any person may appear at a public hearing and submit testimony, either individually or as a representative of a person or an organization. Each person who appears at a public hearing shall be identified, state an address, and if appearing on behalf of a person or organization, state the name of the person or organization being represented. If the person states they represent an organization, the body conducting the hearing may request written evidence of that person's authority to speak on behalf of the organization in regard to the matter under consideration.
 3. **Exclusion of Testimony.** The body conducting the public hearing may exclude testimony that it finds to be irrelevant, immaterial, or unduly repetitious.
 4. **Offers of Testimony.** In the event any testimony is excluded as irrelevant, immaterial, or unduly repetitious, the person submitting such testimony shall have an opportunity at that hearing to offer such testimony to be entered into the record. Such offer shall be made at the public hearing.
 5. **Continuance of Public Hearing.** The body conducting the public hearing may, on its own motion or at the request of any person, continue the public hearing to a fixed date, time, and place. An applicant shall have the right to request and be granted one continuance. Any subsequent continuances requested by any party shall be granted at the discretion of the body conducting the public hearing only upon good cause shown.
 6. **Recording.** A record of the hearing shall be kept as follows.
 - a. **General.** The body conducting the public hearing shall record the public hearing. The written or taped record of oral proceedings (including testimony and statements of personal opinions), the hearing minutes, all applications, exhibits and papers submitted in any proceeding before the review board, the staff report, and the recommendation or decision shall constitute the record. The establishment of a verbatim transcript, if requested, shall be the sole responsibility of the applicant.
 - b. **Public Record.** All records of public hearings conducted by an advisory or decision-making body shall be a public record, and open for inspection at the offices of the Director during normal business hours upon reasonable notice.
 - c. **Copy.** A copy of the public hearing record may be obtained by any person upon applying to the Director and paying the cost for duplication of the record.
 7. **Close of Hearing.** Upon the completion of all testimony or public comment, the hearing shall be closed. No further direct or informal testimony, comments or evidence shall be provided or considered on the matter. The applicant may be asked questions or allowed to comment on proposed conditions.
- C. **General Procedures and Findings Following Public Hearing.**
1. **Time.** Any review body conducting the hearing shall act in accord with any time limits established in state law, this Development Code or the body's own by-laws. Action shall be taken as promptly as possible in consideration of the interests of the applicant, the citizens of the County, and shall

include a recommendation or decision of approval, approval with conditions, or disapproval (whichever is appropriate).

2. **Form of Decisions.** The form of all decisions shall include at least the following elements:

- a. A summary of the information presented before the body;
- b. A statement of findings or other factors considered, whichever is appropriate, and a statement of the basis upon which such facts were applied with respect to the relevant review standards, if required by state law; and
- c. A statement of a recommendation or decision of approval, approval with conditions or disapproval (whichever is appropriate).



BEAUFORT COUNTY COUNCIL AGENDA ITEM SUMMARY

ITEM TITLE:
Recommend Approval of an Ordinance Adopting Amendments to Ch 38. Article II. Trash and Litter Control of the Beaufort County Code of Ordinances
MEETING NAME AND DATE:
Community Services and Land Use – September 11 th , 2023
PRESENTER INFORMATION:
Chuck Atkinson - Assistant County Administrator, Development and Recreation Michael Brantley – Building Codes/Code Enforcement Director (10 mins)
ITEM BACKGROUND:
May 2005 - County Council adopted Article II of the Code of Ordinances for litter. October 2007 – County Council adopted Chapter 62 of the Code of Ordinances for Solid Waste
PROJECT / ITEM NARRATIVE:
As Beaufort County has enforced the ordinances pertaining to Litter between both Code Enforcement and Public Works Staff, conflicting language between the two ordinances was recognized. The adoption of the amendments to Chapter 38 Article II, as noted in Exhibit A, of the Beaufort County Code of Ordinances provides continuity to the language, as well as the enforcement effort of both departments. (Underlined and highlighted sections of Exhibit A are additions. Stricken through sections of Exhibit A are deletions.)
FISCAL IMPACT:
There are no fiscal impacts associated with the adoption of the proposed amendments to Ch 38. Article II.
STAFF RECOMMENDATIONS TO COUNCIL:
Staff recommends approval of the amendments to Chapter 38 Article II. Trash and Litter Control of the Beaufort County Code of Ordinances.
OPTIONS FOR COUNCIL MOTION:
Motion to approve/deny the adoption of the amendments to Chapter 38. Article II. Trash and Litter Control of the Beaufort County Code of Ordinances. (Next Step – Upon approval, send to County Council for First Reading)

ORDINANCE 2023/ XX

An Ordinance Adopting Amendments to Chapter 38. Article II. Trash and Litter Control of Beaufort County Ordinances.

WHEREAS, in May of 2005, Beaufort County adopted Chapter 38, Article II – Trash and Litter Control; and

WHEREAS, on October 22, 2007, Beaufort County adopted Chapter 62 of the Beaufort County Code of Ordinance for Solid Waste; and

WHEREAS, staff of Code Enforcement and Public Works Departments found inconsistent and conflicting language for litter control enforcement between Chapter 38, Article II and Chapter 62; and

WHEREAS, staff wish to amend Chapter 38, Article II to reflect language found within Chapter 62, as set forth in Exhibit A. (Underlined and highlighted sections of Exhibit A are additions. Stricken through sections of Exhibit A are deletions.)

NOW, THEREFORE, BE IT ORDAINED BY BEAUFORT COUNTY COUNCIL THAT Chapter 38, Article II, Trash and Litter Control which appears in Beaufort County Code of Ordinances is hereby amended as set forth in Exhibit A.

Adopted this _____ day of _____ 2023

COUNTY COUNCIL OF BEAUFORT COUNTY

By: _____

Joseph Passiment, Chairman

ATTEST:

Sarah w. Brock, JD,
Clerk to Council

ARTICLE II. TRASH AND LITTER CONTROL

Sec. 38-26. Definitions.

The following words and terms shall have the meaning respectively ascribed to them in this section:

- (1) **Bulky waste** means household furniture, electronic appliances (such as televisions, stereos, microwave ovens), lawn mowers, door and window screens, swing sets, oversized children's toys, lawn furniture, wading pools, barbecue grills, scrap metal whole or parts of boats and automobiles, and items banned from the landfill such as white goods (stoves, refrigerators, freezers, washers, dryers, etc.), tires and waste tires or other items generated by a household as part of its solid waste which are too large for placement in a garbage container.
- (2) **Container** means a watertight receptacle made of metal, heavy-duty plastic, or material of similar strength with a tightfitting cover for storage and disposal of solid waste.
- (3) **County Administrator** means The Beaufort County Administrator or his/her designated agent.
- (~~3~~4) **Litter** means any unsecured or inadequately secured and improperly stored or disposed solid waste placed, thrown, dropped, deposited, blown, leaked or in any other manner distributed as prohibited by the provisions of this article.
- (~~4~~5) **Private property** includes, but is not limited to, the following exterior locations owned by private individuals, firms, corporations, institutions or organizations: yards, grounds, driveways, entrance ways, passageways, parking areas, working areas, vacant lots, drainage basins and on-site stormwater collection/retention or detention areas, loading and unloading areas, storage facilities, contiguous and noncontiguous open lot storage areas and recreation facilities.
- (~~5~~6) **Public property** includes, but is not limited to, the following exterior locations: streets, street medians, roads, road medians, catch basins, state, county or municipally maintained ditches, sidewalks, strips of land between sidewalk and street lanes, alleys, public rights-of-way, public parking lots, school grounds, housing project grounds, publicly owned vacant lots, recreational facilities, including, but not limited to, parks, conservation areas, boat landings, and beaches, waterways and bodies of water.
- (~~6~~7) **Putrescible waste** means a solid waste that contains organic matter capable of being decomposed by microorganisms causing offensive odors, gases, or other offensive conditions, including, but is not limited to, food waste, garbage, general household, commercial, industrial, or agricultural waste.
- (~~7~~8) **Solid waste** means garbage, refuse, litter, rubbish, trash or any material including recyclable materials, and arboreal or yard waste materials resulting from industrial, commercial, agricultural or residential activities not otherwise disposable or reusable in accordance with state regulations.
- (~~8~~9) **Unightly maintenance of property** includes any overgrowth of grasses, bushes, shrubs, weeds, trees, vines, limbs or branches, rank vegetation, excessive collection and storage of putrescible or nonputrescible solid waste, loosely strewn construction and demolition debris (including, but not limited to, all residential and commercial building materials, paint, tools, lumber, fencing, bricks, concrete and other masonry materials), automobile repair or reconstruction items (including, but not limited to, used vehicle parts or whole and partial segments of vehicle engines, drive trains, frames, auto body panels, tires, and wheels), appliances, household fixtures and furnishings (including, but not limited to, stoves, refrigerators, freezers, washers, drivers, sinks, bathtubs, and furniture intended for interior use),

external to the primary residential, commercial or industrial unit or a defined screen storage area or secondary storage facility, which will or is likely to constitute a nuisance or health hazard.

(9-10) **Vehicle** means any device capable of being moved upon a public highway or roadway and in, upon or by which any property is, or may be transported or drawn upon a public highway or roadway.

(11) **Waste** means a material, substance or byproduct eliminated or discarded as no longer useful required or wanted (including, but not limited to, refuse, litter, debris, junk, scrap, rubbish, garbage, trash, leftover, unused).

(12) **Rank vegetation** means dense, uncultivated, vegetative overgrowth or uncultivated briars, vines, or other similar vegetation.

(13) **Yard waste** means solid waste consisting solely of vegetative matter resulting from landscaping maintenance.

(Ord. No. 2002-5, § I, 2-11-02)

Sec. 38-27. Littering by pedestrians and motorists.

Provisions in this section are not intended to replace provisions of S.C. Code, 1976, § 16-11-700, as amended, which section is incorporated herein by reference.

- (1) It shall be unlawful for any person to drop, leave, throw, discard, place or in any way to intentionally or unintentionally deposit or dispose of litter or solid waste in any manner or amount on any public or private property or along any street, road, highway, curb, sidewalk, or public right of way within Beaufort County, except in containers or areas lawfully provided for such purposes.
- (2) In the prosecution charging a violation of the above subsection (1), from any vehicle, proof that the particular vehicle described in the complaint was the origin of the litter or solid waste, together with proof that the defendant named in the complaint was at the time of such violation, the registered owner of said vehicle, shall constitute in evidence a presumption that the registered owner or his designee to whom he gave permission or authorization to operate said vehicle, committed the violation. Origin of the litter or solid waste may be substantiated by documentation or information contained on, within or through the litter or solid waste which establishes ownership of the litter or solid waste to either the registered owner or a designee to whom permission or authorization was granted or because of assumed permission or authorization being granted due to the relationship between the registered owner and the driver.
- (3) It shall be the duty of every person distributing commercial handbills, leaflets, posters, flyers or any other advertising or information materials to take all appropriate and necessary measures to keep such materials from littering public or private property.
- (4) To prevent litter by pedestrians, motorists and property owners, all publicly used establishments and institutions, shall provide readily accessible solid waste containers that shall be regularly emptied and maintained in good condition. Such containers shall be of sufficient size and dimension to adequately handle the solid waste generated as a part of the delivery of goods and services to the public. This requirement shall be applicable to, but not limited to, fast-food outlets, shopping centers, convenience stores, supermarkets, service stations, commercial parking lots, mobile canteens, motels and hotels, hospitals, schools, colleges or other public/private institutions.

(Ord. No. 2002-5, § II, 2-11-02)

Sec. 38-28. Litter to be covered to prevent it from escaping from vehicle during transportation.

No vehicle which transports litter may be driven or moved on any highway unless the litter is secured by means of a covering which is fastened securely so as to prevent any of its load from dropping, sifting, leaking, or otherwise escaping from the vehicle.

(Ord. No. 2002-5, § III, 2-11-02)

Sec. 38-29. Loading and unloading operations.

- (1) The owner or principal manager of any establishment or institution where packing and unpacking, and/or loading and unloading of materials takes place at exterior locations, shall provide suitable containers there for the proper collection and storage of waste materials. Such establishment owners and managers shall ensure that all tenants and their employees are aware of good waste handling practices and that these practices are being routinely practiced to prevent the blowing, dropping, or scattering of solid waste materials from their storage units or during transfer to a collection vehicle for disposal or recycling.
- (2) It shall be the duty and responsibility of the owner, tenant, lessee, or their designees to remove or cause to be removed, at the end of each working day, any solid waste materials that have not been containerized in the proximity of these establishments and in and around the public access areas of these establishments.

(Ord. No. 2002-5, § IV, 2-11-02)

Sec. 38-30. Construction, renovation or demolition projects.

- (1) This article shall make enforceable those provisions contained in the standard A.I.A. contract between an owner and contractor governing the responsibility for solid waste and construction debris.
- (2) It shall be the duty and responsibility of the owner, agent, contractor, or subcontractor to have adequate on-site containers and organized temporary storage areas, which are of sufficient size and dimension to prevent the scattering, dropping, sifting, blowing of solid waste on-site and during the transfer of such solid waste to a solid waste collection vehicle for disposal or recycling, for the retention of all solid waste materials produced as a direct or indirect result of a construction, renovation or demolition project. It shall be the responsibility of the owner, agent, contractor or subcontractor to ensure all solid waste materials are properly disposed in a county designated disposal facility.
- (3) It shall be unlawful to dispose of broken or whole bricks, broken or whole blocks, or cured/uncured concrete, land-clearing debris or another other type of solid waste anywhere in the unincorporated area of the county except at landfills permitted by the state under regulations R.61-107.11, Part IV, R.61-107.16 or R.61-107.258 and permitted consistent with the provisions of Sec. 62-46 of this chapter. Responsibility for the immediate removal and proper disposal of such waste from property is upon the person convicted under this chapter. However, if there is no conviction, the responsibility for removal and proper disposal shall be upon the owner and/or occupant of the property where the waste was deposited.
- (4) Organized collection of solid waste shall be at a frequency which ensures the prevention of hazards and nuisances to human health and the environment. It shall be unlawful for the owner(s) of such

container(s) to fail to pick up and properly dispose of the waste therein at a frequency that ensures the container does not overflow the container.

- (5) It shall be the duty of the owner, agent, contractor, or subcontractor to remove solid waste and/or bulky waste as often as may be necessary to prevent the accumulation of such waste.

(Ord. No. 2002-5, § V, 2-11-02)

Sec. 38-31. Commercial material containerization and removal.

- (1) All establishments, businesses or institutions including, but not limited to, apartments, condominium complexes, restaurants, schools, convenience stores, offices, retail and wholesale business concerns, which generate solid waste requiring collection, shall use containers to accommodate the normal volume of materials generated therein between collection events.
- (2) It shall be the duty and responsibility of any establishment, institution, business, commercial or industrial activity to make appropriate arrangements for collection and disposal of all solid waste generated by the business or its customers.
- (3) It shall be the duty and responsibility of any establishment, institution, business, commercial or industrial activity to ensure the area surrounding solid waste containers remain free of litter and that all solid waste materials have been containerized or bulky items, too large to be containerized, be stored in a defined storage area, screened from view.
- (4) It shall be the duty of any establishment, institution, business, commercial or industrial activity, to remove solid waste and/or bulky waste as often as may be necessary to prevent the accumulation of such waste.

(Ord. No. 2002-5, § VI, 2-11-02)

Sec. 38-32. Property Maintenance ~~Keeping property clean.~~

- (1) It shall be the duty and responsibility of the owner, tenant, lessee, or designee ~~owner, agent, occupant or lessee~~ of any property to keep exterior private and public property free of litter and solid waste. This requirement applies not only to removal of loose litter and solid waste, but to litter and solid waste that is or has become trapped at such locations as fences, wall bases, ditches, grassy and planted areas, borders, embankments, bumper stops, curbed area or other such lodging points.
- (2) It shall be unlawful to sweep or push litter from buildings, or property, onto strips in the street, sidewalks or storm drainage ditches.
- ~~(3) If any owner, agent, occupant or lessee fails to remove litter from any private property, Beaufort County shall serve written notice to the owner or appointed agent to correct said violation within five days. Failure to comply shall constitute grounds for prosecution.~~
- ~~(4) It shall be unlawful for the owner or owners of any property in the unincorporated areas of Beaufort County, to disobey or fail to comply with any provision of this article.~~
- ~~(5) Unsightly maintenance of property, as defined above in section 38-26, is prohibited.~~
- (3) It shall be unlawful to accumulate solid or bulky waste on, or maintain private property in an unsightly manner, as defined above in Section 38-26 of this Article. It shall be the duty of the owner, agent, occupant, or lessee of any improved or unimproved property in any unincorporated area within the county, to remove solid waste and/or bulky waste as often as may be necessary to prevent the accumulation of such waste.

- (4) ***Unlawful disposal or accumulation.*** It shall be unlawful for any person to dispose of, or cause to be disposed of, or allow to accumulate, or for any property owner to allow any person to dispose of, or cause to be disposed of, or cause to accumulate any type of solid waste anywhere in the county except at a solid waste management facility that has been approved by County Council and/or the South Carolina DHEC.
- (5) ***Duties of owner, etc.*** It shall be the duty of any owner, lessee, occupant, agent, or representative of the owner of any lot or parcel of land in the county to remove and properly dispose of such solid waste as often as may be necessary to prevent the accumulation of such waste. Furthermore, it shall be the responsibility of the owner, lessee, occupant, agent, or representative of the owner to limit access to said property such that indiscriminate disposal of solid waste is minimized.
- (6) ***Declaration of nuisance.*** Solid waste allowed to accumulate and remain on any lot or parcel of land in the unincorporated area of the county may be deemed and declared a nuisance by the County Administrator.
- (7) ***Notice to owner, etc., to remove.*** Whenever the County Administrator shall find that solid waste has been allowed to accumulate and remain upon any lot or parcel of land in the county in such a manner as to constitute a nuisance, the county administrator may serve written notice upon the owner, or the occupant of the premises, or upon the agent or representative of the owner of such land having control thereof to comply with the provisions of this chapter. It shall be sufficient notification to personally deliver the notice to the owner (or occupant or agent), or to deposit a copy of such in the United States mail, properly stamped, and directed to the owner (or occupant or agent) at his/her address of record, or to post a copy of the notice upon such premises.
- (8) ***Failure to comply with notice.*** If the person to whom the notice is directed, under the provisions of the preceding subsection fails or neglects to cause such solid waste to be removed from any such premises and properly disposed of within ten days after such notice has been served or deposited in the United States mail, or posted upon premises, such person shall be deemed guilty of a misdemeanor and subject to the penalty provisions of this chapter.
- (9) ***Removal by the County.*** In the event any property is determined to be a nuisance, and 20 days has elapsed after such notice has been served, deposited in the United States mail, or posted upon the premises, then the county administrator may enter upon any such property and abate such nuisance by removing and disposing of the solid waste, and the cost of doing so may become a lien upon the property affected, or may be recovered by the county through judgment proceedings initiated in a court of competent jurisdiction.

(Ord. No. 2002-5, § VII, 2-11-02; Ord. No. 2018/47, 11-5-2018)

Sec. 38-33 Weeds and rank vegetation. RELOCATED FROM SW&R CHAPTER 62

- (1) It shall be the duty of the owner, agent, occupant, or lessee of any improved residential or commercial property in any unincorporated area within the county, to cut, or cause to be cut any, overgrowth of grasses, weeds, and rank vegetation as often as may be necessary to prevent the property becoming unsightly.
- (2) ***Declaration of nuisance.*** Any residential lot/parcel or any nonresidential lot/parcel located contiguous to a residential lot in the county that becomes substantially overgrown with grass, weeds, and/or rank vegetation such that it poses potential safety risks to humans and/or becomes a harborage for vectors may be deemed and declared a nuisance by the County Administrator.
- (3) ***Duties of owner, etc.*** It shall be the duty of any owner, lessee, occupant, agent, or representative of the owner of any residential lot/parcel or any nonresidential lot/parcel located contiguous to a

residential lot in the county to cut, trim and remove for proper disposal such grass, weeds, and/or rank vegetation as often as may be necessary to prevent the growth of such weeds and rank vegetation that shall constitute a nuisance. However, lots of three acres or more shall only be required to cut 100 feet from contiguous road(s) and each side property line.

- (4) **Notice to owner, etc., to remove.** Whenever the County Administrator shall find that overgrowth of grass, weeds, and/or rank vegetation on a residential lot/parcel or any nonresidential lot/parcel located contiguous to a residential lot in the county constitutes a nuisance, the County Administrator may serve written notice upon the owner, or the occupant of the premises, or upon the agent or representative of the owner of such land having control thereof to comply with the provisions of this section. It shall be sufficient notification to personally deliver the notice to the owner (or occupant or agent), or to deposit a copy of such in the United States mail, properly stamped, and directed to the owner (or occupant or agent) at his/her address of record, or to post a copy of the notice upon such premises.
- (5) **Failure to comply with notice.** If the person to whom the notice is directed, under the provisions of the preceding subsection fails or neglects to cause such overgrowth of weeds and rank vegetation to be removed from any such premises and properly disposed of within ten days after such notice has been served or deposited in the United States mail, or posted upon premises, such person shall be deemed guilty of a misdemeanor and subject to the penalty provisions of this chapter.
- (6) **Removal by County.** In the event any overgrowth of weeds and rank vegetation is determined to be a nuisance, and twenty (20) days has elapsed after such notice has been served, deposited in the United States mail, or posted upon the premises, then the county administrator or his/her designated contractor may enter upon any such property and abate such nuisance by cutting, trimming, removing and disposing of the vegetative waste, and the cost of doing so, pursuant to the cleanup fee structure noted below, may become a lien upon the property affected, or may be recovered by the County through judgment proceedings initiated in a court of competent jurisdiction.

Sec. 38-33 38-34. Correction of violations.

- (1) If an owner or his/her agent fails to comply with the written notice or citation to correct a violation of this article and said violation is determined to be a threat to the health and safety of the citizens of Beaufort County, the county may, at the county's sole discretion, utilize employees of Beaufort County or any other person employed for that purpose to go upon the property to correct the conditions thereupon existing.
- (2) All costs incurred for correcting the conditions on said property and/or for the removal of all litter and/or solid waste, or other unhealthy or unsightly materials or any other actions reasonably taken by Beaufort County to abate the same or to remove the threat to the public's health and safety shall be a lien against the real property upon which such cost was incurred. All costs incurred by the county in preparing, recording, collecting and satisfying said lien shall be included therein including, but not limited to, reasonable attorney's fees, costs and disbursements.

(Ord. No. 2002-5, § VIII, 2-11-02)

Sec. 38-35. Dumping and depositing material in the rivers, creeks, drainage canals and ditches prohibited.

- (1) No person shall throw or place any refuse, paper, trash, glass, nails, tacks, wire, bottles, cans, grass clippings, brush, yard trash, concrete, earthen fill, garbage, containers, or litter or other debris in any ditch, stream, river, or retention basin that regularly or periodically carries surface water runoff. Any

persons who deposits any of the above shall remove it or shall cause it to be removed therefrom immediately.

- (2) ~~Any person violating the provisions of this section is guilty of a misdemeanor and upon conviction must be fined not less than \$500.00 or 30 days in jail for each offense.~~
- (3) ~~In the event that the County of Beaufort deems it necessary to bring civil action to enforce the terms of this section, the violator shall be responsible for all court costs and attorney fees incurred by the county.~~

(Ord. No. 95-45, §§ 1—3, 12-11-95)

Sec. ~~38-34~~ 38-36. Penalties.

- (1) A person violating the provisions of this article is guilty of a misdemeanor and, upon conviction, must be fined not ~~less than \$100.00 nor more than \$200.00~~ more than \$500.00 or confined for not more than 30 days, or both for each offense.
- (2) ~~Violations and~~ Enforcement of this article shall be ~~executed and prosecuted~~ by commissioned code enforcement officers, using the County Courtesy Summons Ordinance (93/34), or by the ~~sheriff and his deputies~~ Beaufort County Sheriff's Office or any other Law Enforcement Agency which has jurisdiction over the area in which the violation occurs.
- (3) Each violation of this Ordinance shall constitute a separate offense. Each day a violation continues shall constitute a separate offense and may subject the violator to the penalties prescribed in this article for each offense.
- (4) In the event that the County deems it necessary to bring civil action to enforce the terms of this chapter, the violator shall be responsible for all court costs and attorney fees incurred by the county.

(Ord. No. 2002-5, § I, 2-11-02)

Secs. ~~38-36~~ 38-37—38-60. Reserved.

ARTICLE II. TRASH AND LITTER CONTROL

Sec. 38-26. Definitions.

The following words and terms shall have the meaning respectively ascribed to them in this section:

- (1) **Bulky waste** means household furniture, electronic appliances (such as televisions, stereos, microwave ovens), lawn mowers, door and window screens, swing sets, oversized children's toys, lawn furniture, wading pools, barbecue grills, scrap metal whole or parts of boats and automobiles, and items banned from the landfill such as white goods (stoves, refrigerators, freezers, washers, dryers, etc.), tires and waste tires or other items generated by a household as part of its solid waste which are too large for placement in a garbage container.
- (2) **Container** means a watertight receptacle made of metal, heavy-duty plastic, or material of similar strength with a tightfitting cover for storage and disposal of solid waste.
- (3) **County Administrator** means The Beaufort County Administrator or his/her designated agent.
- (4) **Litter** means any unsecured or inadequately secured and improperly stored or disposed solid waste placed, thrown, dropped, deposited, blown, leaked or in any other manner distributed as prohibited by the provisions of this article.
- (5) **Private property** includes, but is not limited to, the following exterior locations owned by private individuals, firms, corporations, institutions, or organizations: yards, grounds, driveways, entrance ways, passageways, parking areas, working areas, vacant lots, drainage basins and on-site stormwater collection/retention or detention areas, loading and unloading areas, storage facilities, contiguous and noncontiguous open lot storage areas and recreation facilities.
- (6) **Public property** includes, but is not limited to, the following exterior locations: streets, street medians, roads, road medians, catch basins, state, county or municipally maintained ditches, sidewalks, strips of land between sidewalk and street lanes, alleys, public rights-of-way, public parking lots, school grounds, housing project grounds, publicly owned vacant lots, recreational facilities, including, but not limited to, parks, conservation areas, boat landings, and beaches, waterways and bodies of water.
- (7) **Putrescible waste** means a solid waste that contains organic matter capable of being decomposed by microorganisms causing offensive odors, gases, or other offensive conditions, including, but is not limited to, food waste, garbage, general household, commercial, industrial, or agricultural waste.
- (8) **Solid waste** means garbage, refuse, litter, rubbish, trash or any material including recyclable materials, and arboreal or yard waste materials resulting from industrial, commercial, agricultural or residential activities not otherwise disposable or reusable in accordance with state regulations.
- (9) **Unightly maintenance of property** includes any overgrowth of grasses, bushes, shrubs, weeds, trees, vines, limbs or branches, rank vegetation, excessive collection and storage of putrescible or nonputrescible solid waste, loosely strewn construction and demolition debris (including, but not limited to, all residential and commercial building materials, paint, tools, lumber, fencing, bricks, concrete and other masonry materials), automobile repair or reconstruction items (including, but not limited to, used vehicle parts or whole and partial segments of vehicle engines, drive trains, frames, auto body panels, tires, and wheels), appliances, household fixtures and furnishings (including, but not limited to, stoves, refrigerators, freezers, washers, drivers, sinks, bathtubs, and furniture intended for interior use),

external to the primary residential, commercial or industrial unit or a defined screen storage area or secondary storage facility, which will or is likely to constitute a nuisance or health hazard.

- (10) **Vehicle** means any device capable of being moved upon a public highway or roadway and in, upon or by which any property is, or may be transported or drawn upon a public highway or roadway.
- (11) **Waste** means a material, substance or byproduct eliminated or discarded as no longer useful required or wanted (including, but not limited to, refuse, litter, debris, junk, scrap, rubbish, garbage, trash, leftover, unused).
- (12) **Rank vegetation** means dense, uncultivated, vegetative overgrowth or uncultivated briars, vines, or other similar vegetation.
- (13) **Yard waste** means solid waste consisting solely of vegetative matter resulting from landscaping maintenance.

(Ord. No. 2002-5, § I, 2-11-02)

Sec. 38-27. Littering by pedestrians and motorists.

Provisions in this section are not intended to replace provisions of S.C. Code, 1976, § 16-11-700, as amended, which section is incorporated herein by reference.

- (1) It shall be unlawful for any person to drop, leave, throw, discard, place or in any way to intentionally or unintentionally deposit or dispose of litter or solid waste in any manner or amount on any public or private property or along any street, road, highway, curb, sidewalk, or public right of way within Beaufort County, except in containers or areas lawfully provided for such purposes.
- (2) In the prosecution charging a violation of the above subsection (1), from any vehicle, proof that the particular vehicle described in the complaint was the origin of the litter or solid waste, together with proof that the defendant named in the complaint was at the time of such violation, the registered owner of said vehicle, shall constitute in evidence a presumption that the registered owner or his designee to whom he gave permission or authorization to operate said vehicle, committed the violation. Origin of the litter or solid waste may be substantiated by documentation or information contained on, within or through the litter or solid waste which establishes ownership of the litter or solid waste to either the registered owner or a designee to whom permission or authorization was granted or because of assumed permission or authorization being granted due to the relationship between the registered owner and the driver.
- (3) It shall be the duty of every person distributing commercial handbills, leaflets, posters, flyers or any other advertising or information materials to take all appropriate and necessary measures to keep such materials from littering public or private property.
- (4) To prevent litter by pedestrians, motorists and property owners, all publicly used establishments and institutions, shall provide readily accessible solid waste containers that shall be regularly emptied and maintained in good condition. Such containers shall be of sufficient size and dimension to adequately handle the solid waste generated as a part of the delivery of goods and services to the public. This requirement shall be applicable to, but not limited to, fast-food outlets, shopping centers, convenience stores, supermarkets, service stations, commercial parking lots, mobile canteens, motels and hotels, hospitals, schools, colleges or other public/private institutions.

(Ord. No. 2002-5, § II, 2-11-02)

Sec. 38-28. Litter to be covered to prevent it from escaping from vehicle during transportation.

No vehicle which transports litter may be driven or moved on any highway unless the litter is secured by means of a covering which is fastened securely so as to prevent any of its load from dropping, sifting, leaking, or otherwise escaping from the vehicle.

(Ord. No. 2002-5, § III, 2-11-02)

Sec. 38-29. Loading and unloading operations.

- (1) The owner or principal manager of any establishment or institution where packing and unpacking, and/or loading and unloading of materials takes place at exterior locations, shall provide suitable containers there for the proper collection and storage of waste materials. Such establishment owners and managers shall ensure that all tenants and their employees are aware of good waste handling practices and that these practices are being routinely practiced to prevent the blowing, dropping, or scattering of solid waste materials from their storage units or during transfer to a collection vehicle for disposal or recycling.
- (2) It shall be the duty and responsibility of the owner, tenant, lessee, or their designees to remove or cause to be removed, at the end of each working day, any solid waste materials that have not been containerized in the proximity of these establishments and in and around the public access areas of these establishments.

(Ord. No. 2002-5, § IV, 2-11-02)

Sec. 38-30. Construction, renovation or demolition projects.

- (1) This article shall make enforceable those provisions contained in the standard A.I.A. contract between an owner and contractor governing the responsibility for solid waste and construction debris.
- (2) It shall be the duty and responsibility of the owner, agent, contractor, or subcontractor to have adequate on-site containers and organized temporary storage areas, which are of sufficient size and dimension to prevent the scattering, dropping, sifting, blowing of solid waste on-site and during the transfer of such solid waste to a solid waste collection vehicle for disposal or recycling, for the retention of all solid waste materials produced as a direct or indirect result of a construction, renovation or demolition project. It shall be the responsibility of the owner, agent, contractor or subcontractor to ensure all solid waste materials are properly disposed in a county designated disposal facility.
- (3) It shall be unlawful to dispose of broken or whole bricks, broken or whole blocks, or cured/uncured concrete, land-clearing debris or another other type of solid waste anywhere in the unincorporated area of the county except at landfills permitted by the state under regulations R.61-107.11, Part IV, R.61-107.16 or R.61-107.258 and permitted consistent with the provisions of Sec. 62-46 of this chapter. Responsibility for the immediate removal and proper disposal of such waste from property is upon the person convicted under this chapter. However, if there is no conviction, the responsibility for removal and proper disposal shall be upon the owner and/or occupant of the property where the waste was deposited.
- (4) Organized collection of solid waste shall be at a frequency which ensures the prevention of hazards and nuisances to human health and the environment. It shall be unlawful for the owner(s) of such

container(s) to fail to pick up and properly dispose of the waste therein at a frequency that ensures the container does not overflow the container.

- (5) It shall be the duty of the owner, agent, contractor, or subcontractor to remove solid waste and/or bulky waste as often as may be necessary to prevent the accumulation of such waste.

(Ord. No. 2002-5, § V, 2-11-02)

Sec. 38-31. Commercial material containerization and removal.

- (1) All establishments, businesses or institutions including, but not limited to, apartments, condominium complexes, restaurants, schools, convenience stores, offices, retail and wholesale business concerns, which generate solid waste requiring collection, shall use containers to accommodate the normal volume of materials generated therein between collection events.
- (2) It shall be the duty and responsibility of any establishment, institution, business, commercial or industrial activity to make appropriate arrangements for collection and disposal of all solid waste generated by the business or its customers.
- (3) It shall be the duty and responsibility of any establishment, institution, business, commercial or industrial activity to ensure the area surrounding solid waste containers remain free of litter and that all solid waste materials have been containerized or bulky items, too large to be containerized, be stored in a defined storage area, screened from view.
- (4) It shall be the duty of any establishment, institution, business, commercial or industrial activity, to remove solid waste and/or bulky waste as often as may be necessary to prevent the accumulation of such waste.

(Ord. No. 2002-5, § VI, 2-11-02)

Sec. 38-32. Property Maintenance

- (1) It shall be the duty and responsibility of the owner, tenant, lessee, or designee of any property to keep exterior private and public property free of litter and solid waste. This requirement applies not only to removal of loose litter and solid waste, but to litter and solid waste that is or has become trapped at such locations as fences, wall bases, ditches, grassy and planted areas, borders, embankments, bumper stops, curbed area or other such lodging points.
- (2) It shall be unlawful to sweep or push litter from buildings, or property, onto strips in the street, sidewalks or storm drainage ditches.
- (3) It shall be unlawful to accumulate solid or bulky waste on, or maintain private property in an unsightly manner, as defined above in Section 38-26 of this Article. It shall be the duty of the owner, agent, occupant, or lessee of any improved or unimproved property in any unincorporated area within the county, to remove solid waste and/or bulky waste as often as may be necessary to prevent the accumulation of such waste.
- (4) **Unlawful disposal or accumulation.** It shall be unlawful for any person to dispose of, or cause to be disposed of, or allow to accumulate, or for any property owner to allow any person to dispose of, or cause to be disposed of, or cause to accumulate any type of solid waste anywhere in the county except at a solid waste management facility that has been approved by County Council and/or the South Carolina DHEC.
- (5) **Duties of owner, etc.** It shall be the duty of any owner, lessee, occupant, agent, or representative of the owner of any lot or parcel of land in the county to remove and properly dispose of such solid

waste as often as may be necessary to prevent the accumulation of such waste. Furthermore, it shall be the responsibility of the owner, lessee, occupant, agent, or representative of the owner to limit access to said property such that indiscriminate disposal of solid waste is minimized.

- (6) **Declaration of nuisance.** Solid waste allowed to accumulate and remain on any lot or parcel of land in the unincorporated area of the county may be deemed and declared a nuisance by the County Administrator.
- (7) **Notice to owner, etc., to remove.** Whenever the County Administrator shall find that solid waste has been allowed to accumulate and remain upon any lot or parcel of land in the county in such a manner as to constitute a nuisance, the county administrator may serve written notice upon the owner, or the occupant of the premises, or upon the agent or representative of the owner of such land having control thereof to comply with the provisions of this chapter. It shall be sufficient notification to personally deliver the notice to the owner (or occupant or agent), or to deposit a copy of such in the United States mail, properly stamped, and directed to the owner (or occupant or agent) at his/her address of record, or to post a copy of the notice upon such premises.
- (8) **Failure to comply with notice.** If the person to whom the notice is directed, under the provisions of the preceding subsection fails or neglects to cause such solid waste to be removed from any such premises and properly disposed of within ten days after such notice has been served or deposited in the United States mail, or posted upon premises, such person shall be deemed guilty of a misdemeanor and subject to the penalty provisions of this chapter.
- (9) **Removal by the County.** In the event any property is determined to be a nuisance, and 20 days has elapsed after such notice has been served, deposited in the United States mail, or posted upon the premises, then the county administrator may enter upon any such property and abate such nuisance by removing and disposing of the solid waste, and the cost of doing so may become a lien upon the property affected, or may be recovered by the county through judgment proceedings initiated in a court of competent jurisdiction.

(Ord. No. 2002-5, § VII, 2-11-02; Ord. No. 2018/47, 11-5-2018)

Sec. 38-33. Weeds and rank vegetation.

- (1) It shall be the duty of the owner, agent, occupant, or lessee of any improved residential or commercial property in any unincorporated area within the county, to cut, or cause to cut any, overgrowth of grasses, weeds, and rank vegetation as often as may be necessary to prevent the property becoming unsightly.
- (2) **Declaration of nuisance.** Any residential lot/parcel or any nonresidential lot/parcel located contiguous to a residential lot in the county that becomes substantially overgrown with grass, weeds, and/or rank vegetation such that it poses potential safety risk to humans and/or becomes a harborage for vectors may be deemed and declared a nuisance by the County Administrator.
- (3) **Duties of owner, etc.** It shall be the duty of any owner, lessee, occupant, agent, or representative of the owner of any residential lot/parcel or any nonresidential lot/parcel located contiguous to a residential lot in the county to cut, trim, and remove for proper disposal such grass, weeds, and or rank vegetation as often as may be necessary to prevent the growth of such weeds and rank vegetation that shall constitute a nuisance. However, lots of three acres or more shall only be required to cut 100 feet from contiguous road(s) and each side property line.
- (4) **Notice to owner, etc., to remove.** Whenever the County Administrator shall find that overgrowth of grass, weeds, and/or vegetation on a residential lot or any nonresidential lot/parcel located contiguous to a residential lot in the county constitutes a nuisance, the County Administrator may serve written notice upon the owner, or the occupant of the premises, or upon the agent or representative of the

owner of such land having control thereof to comply with the provisions of this section. It shall be sufficient notification to personally deliver the notice to the owner (or occupant or agent), or to deposit a copy of such in the United States mail, properly stamped, and directed to the owner (or occupant or agent) at his/her address of record, or to post a copy of the notice upon such premises.

- (5) **Failure to comply with notice.** If the person to whom the notice is directed, under the provisions of the preceding subsection fails or neglects to cause such overgrowth of weeds and rank vegetation to be removed from any such premises and properly disposed of within ten days after such notice has been served or deposited in the United States mail, or posted upon premises, such person shall be deemed guilty of a misdemeanor and subject to the penalty provisions of this chapter.
- (6) **Removal by County.** In the event any overgrowth of weeds and rank vegetation is determined to be a nuisance, and twenty (20) days has elapsed after such notice has been served, deposited in the United States mail, or posted upon the premises, then the county administrator or his/her designated contractor may enter upon any such property and abate such nuisance by cutting, trimming, removing and disposing of the vegetative waste, and the cost of doing so, pursuant to the cleanup fee structure noted below, may become a lien upon the property affected, or may be recovered by the County through judgment proceedings initiated in a court of competent jurisdiction.

Sec. 38-34. Correction of violations.

- (1) If an owner or his/her agent fails to comply with the written notice or citation to correct a violation of this article and said violation is determined to be a threat to the health and safety of the citizens of Beaufort County, the county may, at the county's sole discretion, utilize employees of Beaufort County or any other person employed for that purpose to go upon the property to correct the conditions thereupon existing.
- (2) All costs incurred for correcting the conditions on said property and/or for the removal of all litter and/or solid waste, or other unhealthy or unsightly materials or any other actions reasonably taken by Beaufort County to abate the same or to remove the threat to the public's health and safety shall be a lien against the real property upon which such cost was incurred. All costs incurred by the county in preparing, recording, collecting, and satisfying said lien shall be included therein including, but not limited to, reasonable attorney's fees, costs and disbursements.

(Ord. No. 2002-5, § VIII, 2-11-02)

Sec. 38-35. Dumping and depositing material in the rivers, creeks, drainage canals and ditches prohibited.

- (1) No person shall throw or place any refuse, paper, trash, glass, nails, tacks, wire, bottles, cans, grass clippings, brush, yard trash, concrete, earthen fill, garbage, containers, or litter or other debris in any ditch, stream, river, or retention basin that regularly or periodically carries surface water runoff. Any persons who deposit any of the above shall remove it or shall cause it to be removed therefrom immediately.

(Ord. No. 95-45, §§ 1—3, 12-11-95)

Sec. 38-36. Penalties.

- (1) A person violating the provisions of this article is guilty of a misdemeanor and, upon conviction, must be fined not more than \$500.00 or confined for not more than 30 days, or both_for each offense.

- (2) Enforcement of this article shall be by commissioned code enforcement officers, using the County Courtesy Summons Ordinance (93/34), or by the Beaufort County Sheriff's Office or any other Law Enforcement Agency which has jurisdiction over the area in which the violation occurs.
- (3) Each violation of this Ordinance shall constitute a separate offense. Each day a violation continues shall constitute a separate offense and may subject the violator to the penalties prescribed in this article for each offense.
- (4) In the event that the County deems it necessary to bring civil action to enforce the terms of this chapter, the violator shall be responsible for all court costs and attorney fees incurred by the county.

(Ord. No. 2002-5, § I, 2-11-02)

Secs. 38-37—38-60. Reserved.



BEAUFORT COUNTY COUNCIL AGENDA ITEM SUMMARY

Item 15.

ITEM TITLE:
An Ordinance Adopting Amendments to Ch 62. Solid Waste of the Beaufort County Code of Ordinance (\$0.00)
MEETING NAME AND DATE:
Community Services and Land Use – August 10th, 2023
PRESENTER INFORMATION
Jared Fralix, P.E. – Assistant County Administrator, Infrastructure Neil Desai, P.E. – Public Works Director (Alternate) (10 min)
ITEM BACKGROUND:
May 2005 – County Council adopted Article II of the Code of Ordinances for litter. October 2007 – County Council adopted Chapter 62 of the Code of Ordinances for Solid Waste.
PROJECT / ITEM NARRATIVE:
As Beaufort County has enforced the ordinances pertaining to Litter between both Code Enforcement and Public Works Staff, conflicting language between the two ordinances was recognized. The adoption of the amendments to Chapter 62, as noted in Exhibit A, of the Beaufort County Code of Ordinances provides continuity to the language, as well as the enforcement effort of both departments.
FISCAL IMPACT:
There are no fiscal impacts associated with the adoption of the proposed amendments to Ch 62.
STAFF RECOMMENDATIONS TO COUNCIL:
Staff recommends approval of the amendments to Chapter 62. Solid Waste of the Beaufort County Code of Ordinances.
OPTIONS FOR COUNCIL MOTION:
Motion to approve/deny the adoption of the amendments to Chapter 62. Solid Waste of the Beaufort County Code of Ordinances.
(Next Step – Upon approval, send to County Council for First Reading)

Chapter 62 SOLID WASTE¹

ARTICLE I. IN GENERAL

Sec. 62-1. Establishment and administration of solid waste and recycling enterprise system.

- (a) There is hereby created the "solid waste and recycling enterprise system" of the county. The solid waste and recycling enterprise system shall be operated as an administrative division of the county under the responsibility of the county administrator. The county administrator is authorized to (i) establish and organize the county's solid waste and recycling facilities and services as necessary for their useful and efficient operation, (ii) to establish necessary procedures, policies and guidelines for the use of the county's solid waste and recycling facilities and services, and (iii) to recommend appropriate millage or fee and rate schedules for consideration and approval by county council, including any appropriate exemptions. Any millage, fee, or rate recommendations shall be based upon considerations that the county's solid waste and recycling enterprise system will be self-supporting, and adequately funded by all users and classes of users that benefit from county solid waste and recycling facilities and services in future periods. The county administrator is further directed to keep county council advised as to the progress in accomplishing these requirements.
- (b) These provisions shall be applicable within the county and for all solid waste and recycling facilities and services provided by the County.

In addition to collection and disposal of solid waste and collection and processing of recovered materials, other solid waste and recycling facilities and services may be provided within the county. Such other solid waste and recycling facilities and services may be provided within the corporate limits of a municipality in the county by contract with an individual, corporation or municipal governing body in the event (1) the municipality is not providing such services, or (2) permission of the municipal governing body has been obtained in connection with the provision of such facilities and services; otherwise, the county shall not render such facilities and services within such municipality.

The county finds, after due investigation, that the solid waste and recycling enterprise system programs do not conflict, or compete in any way, with the solid waste and recycling services of the municipalities within the county and are entirely complementary thereof and separate therefrom. To the extent that a municipality engages in collection and disposal of solid waste and collection and processing of recovered materials, the county shall not engage in such service within such municipality, and appropriate fee exemptions, if necessary, shall be implemented.

¹Editor's note(s)—Ord. No. 2007/37, adopted Oct. 22, 2007, amended Ch. 62 in its entirety to read as herein set out. Former Ch. 62 consisted of §§ 62-1—62-68, pertained to similar subject matter and derived from the 1982 Code; Ord. No. 064-94, adopted Sept. 6, 1994; an ordinance adopted Nov. 9, 1998; and Ord. No. 006-02HR, adopted Mar. 19, 2002.

Cross reference(s)—Environment, ch. 38; trash and litter control, § 38-26 et seq.; littering or dumping of refuse in rivers, creeks, canals and ditches, § 38-35; health and sanitation, ch. 46; buildings and building regulations, ch. 74; manufactured homes and trailers, ch. 86; littering at Bluffton dock, § 102-66; waste disposal facilities, § 106-1367.

The county administrator may request assistance from the various departments and other officials of the county or municipalities, as may be necessary for the orderly implementation of this chapter. Agreements, including any intergovernmental agreements with municipalities within the county and any necessary or desirable regulations promulgated to carry out this chapter are authorized and shall be subject to prior review and approval of county council.

(Ord. No. 2007/37, 10-22-2007; Ord. No. 2020/19, § 2.A, 6-8-2020; Ord. No. 2021/24, § 2.A, 5-24-2021)

Sec. 62-2. Authority.

- (a) *Authority and purpose.* Beaufort County ("the county") shall provide for the management, collection, and disposal of residential solid waste collected by the county or its agent. The landfills are established pursuant to the authority conferred by S.C. Code 1976, §§ 44-55-1010 through 44-55-1060, as amended, S.C. Code 1976, §44-1-140(11), as amended, and Section 9, Part II, Act No. 410 of 1971 also South Carolina Regulation PC-SW-2, and for the public health, welfare and safety of the citizens of the county. The rules and regulations herein are adopted along with all other South Carolina Department of Health and Environmental Control rules and regulations. All recycling and solid waste activities not in the county system shall coordinate with the county for the purpose of assisting the county with achievement of established state diversion and recycling goals.
- (b) *General.* Section 9 of the General Appropriations Act (Act No. 410) South Carolina Solid Waste Management and Policy Act of 1991, assigns the South Carolina State Board of Health as "the agency over these matters involving real or potential threats to the health of the people of South Carolina, including the handling and disposal of garbage and municipal solid waste . . ." Improper storage, collection and transportation systems create health hazards, odors, impair the aesthetic appearance of the State, encourage wild and domestic animal feeding and exposes residents to undue risks. Section 44-96-20 of the South Carolina Solid Waste Management and Policy Act of 1991, establishes goals for solid waste diversion from municipal solid waste (MSW) landfills and for recycling on a statewide basis, and confer upon counties the responsibility for establishing solid waste management plans, including ordinances, policies and regulations, which support the achievement of the established waste reduction goal to reduce the amount of municipal solid waste disposed of to 3.25 pounds per/person/day or less and to recycle at least 40 percent of municipal solid waste.
- (c) In addition to the foregoing authority, purposes, and general matters, the county finds the solid waste and recycling enterprise system shall serve the following additional purposes:
- (1) To promote the public health, safety and welfare;
 - (2) To ensure that solid waste is transported, stored, treated, processed and disposed of in a manner adequate to protect human health, safety and welfare and the environment;
 - (3) To promote the reduction, recycling, reuse and treatment of solid waste and the recycling of materials which would otherwise be disposed of as solid waste;
 - (4) To provide an efficient method for the collection, transportation, storage, handling, treatment, reduction, recycling, reuse and disposal of solid waste in the county through the establishment, construction and operation of solid waste collection sites and other facilities for the use and benefit of residents of the county and other municipalities, entities or persons who contract for the use of county facilities for the collection of permitted solid waste in accordance with county ordinances and regulations; and
 - (5) To protect and preserve the quality of the environment and to conserve and recycle natural resources.

(Ord. No. 2007/37, 10-22-2007; Ord. No. 2020/19, § 2.B, 6-8-2020; Ord. No. 2021/24, § 2.B, 5-24-2021)

Sec. 62-3. Definitions.

For the purpose of this chapter, any definitions contained herein shall apply unless specifically stated. In addition to the definitions contained in this chapter, the articles of this chapter adopt by reference the definition of terms (to the extent they are not inconsistent with definitions specifically contained herein) defined in the South Carolina Solid Waste Policy and Management Act of 1991, S.C. Code § 44-96-10, et seq. and in any regulations promulgated pursuant thereto. Any term not specifically defined shall be construed pursuant to its plain and ordinary meaning. When not inconsistent with the context, words used in the present tense include the future, words used in the plural include the singular, and words used in the singular include the plural. The word "shall" is always mandatory and not merely discretionary.

Agricultural operation: Raising, harvesting, or storing crops or feed, breeding or managing livestock, including the preparation of the products raised thereon for human use and disposed of by marketing or other means. It includes, but is not limited to, agriculture, grazing, horticulture, forestry, and dairy farming.

Apartment: Any building containing more than four contiguous dwelling units or any group of buildings or mobile homes located on a single lot that contains a total of six or more dwelling units owned by the same person.

Backyard composting: The on-site composting of yard waste by the owner or tenant for nonrevenue generating use when all materials are generated and composted on-site.

Bulk container: A manufactured container suitable for emptying by mechanical equipment that has been approved by the county administrator.

Bulky waste: Household furniture, electronic appliances (such as televisions, stereos, microwave ovens), lawn mowers, door and window screens, swing sets, over-sized children's toys, lawn furniture, wading pools, barbecue grills, whole or parts of boats and automobiles, and items banned from landfill such as white goods (stoves, refrigerators, washers, dryers, etc.), tires or other items generated by a household as part of its solid waste which are too large for placement in a garbage container.

Code: The Code of Ordinances of Beaufort County, South Carolina.

Collection: The act of picking up solid waste or recovered materials from residents, businesses, institutions, or industrial generators.

Collector/hauler: Any individual, business, or municipal organization which collects solid waste or recovered materials commercially or as a public service and transports it to a permitted solid waste facility, landfill or recovered materials processing facility.

Combined waste stream: The aggregate waste stream of all tenants or occupants of a business property or complex.

Commercial establishment: Any hotel, motel, apartment, rooming house, business, industrial, public or semipublic establishment of any nature.

Commercial solid waste: Municipal solid waste (including unrecovered recyclable materials) generated by industrial, commercial or business activities. This includes solid waste generated within multifamily residences and all solid waste placed in public receptacles on public streets, parks and playgrounds, beaches and other public places (excluding industrial waste as defined herein).

Compost: Humus-like end product of the process of composting waste.

Composting: The process of making compost.

Composting facility: Any facility used in the composting of yard waste, land-clearing debris, chipped untreated wood waste, and/or other organic material thereby providing aerobic, thermophilic decomposition of the solid organic constituents of solid waste to produce a stable, humus-like material.

Construction: Any physical modification to the site at which a potential or proposed solid waste management facility is to be located including, but not limited to, site preparation, clearing, grading, excavation, construction of buildings, installation of liners, etc.

Construction and demolition debris: Any discarded solid wastes resulting from construction, remodeling, repair, and demolition of structures, and road construction. The wastes include, but are not limited to, bricks, concrete, other masonry materials, lumber, road spoils, and paving materials, but do not include solid waste from agricultural operations.

Container means a watertight receptacle made of metal, heavy-duty plastic, or material of similar strength with a tightfitting cover for storage and disposal of solid waste or recovered materials.

Contractor: The person that has entered into a contract with the county to perform solid waste collection.

County: Beaufort County, South Carolina.

County administrator: The Beaufort County Administrator or his/her designated agent.

County council: The governing body of Beaufort County, South Carolina.

Collection center: Any county authorized site designated for collection of residential solid waste, yard waste, bulky items, waste oil and other designated solid waste or recovered materials. Collection centers are intended for residential solid waste and recovered materials.

Debris: Includes, but not limited to, equipment, yard toys, furniture, packaging items, shipping containers, construction and demolition waste, bricks, blocks, concrete, asphalt, metals, lumber, trees, tree limbs, tree stumps, brush or parts thereof, or brush stumps, and/or building materials that are determined to be potentially deleterious to good health, public sanitation and/or public safety.

DHEC: The South Carolina Department of Health and Environmental Control.

Director: Beaufort County Director of Public Works or his/her designated agent.

Disposal: The discharge, deposition, injection, dumping, spilling, or placing of any solid waste into or on any land or water, so that the substance or any constituent thereof may enter the environment or be emitted into the air or discharged into any waters, including groundwater.

Dwelling unit: One or more habitable rooms that are intended to be occupied by one family with facilities for living, sleeping, cooking and eating municipal solid waste(excludes commercial establishments).

Expand or expansion: Any change to a solid waste management facility including a composting facility or change in the status of that facility that:

- (1) Allows or results in an increase in the solid waste disposal capacity for the facility (including either lateral or vertical expansion capacity); or
- (2) Allows or results in an increase (or potential increase) in the annual disposal rate, tonnage limit and/or capacity limit for the facility; or
- (3) Includes or otherwise involves the purchase of additional property that may be utilized for solid waste management of any kind at the facility.

Fiscal year: A twelve-month period from July 1 of the current year to June 30 of the following year.

Franchise collector: The person that has entered into a franchise agreement with the county to perform solid waste and/or recovered materials collection.

Garbage: All accumulations of animal, fruit or vegetable matter that attend the preparation, use, cooking and dealing in, or storage of meats, fish, fowl, fruit, vegetables and any other matter of any nature whatsoever which is subject to decay, putrefaction and the generation of noxious and offensive smells or odors, or which during and after decay may serve as breeding or feeding material for flies and/or germ-carrying insects or vermin; items which due to their ability to retain water can serve as a breeding place for mosquitoes and other water-breeding insects.

Groundwater: Water beneath the land surface in the saturated zone.

Hazardous wastes: Wastes that are defined as hazardous in Section 44-56-20 of the South Carolina Hazardous Waste Management Act.

Household: A person or group of people who occupy a dwelling unit as their usual place of residence.

Household hazardous waste: Any commonly used household hazardous material that is not regulated as hazardous waste when disposed of. This includes, but is not limited to, insecticides, pesticides, paints, lubricants, fertilizers, cleaning agents and polishing compounds. For purposes of this definition, household hazardous waste does not include gasoline or motor oil.

Household quantities: Quantities of solid waste reasonably generated in the course of typical domestic activities from single-family residential dwelling units including minor renovations to a dwelling unit. Solid wastes from construction projects that require a building permit or evictions of tenants are not considered household quantities. The fact that waste is generated from a single-family primary residence does not necessarily establish household quantities.

Industrial solid waste: Any and all solid waste generated by manufacturing or industrial processes that is not a hazardous waste reduction under subtitle C of the Resource Conservation and Recovery Act.

Land-clearing debris: Organic waste such as trees, limbs, brush, and stumps mingled with small amounts of dirt that is produced as a result of clearing and grubbing operations but does not include solid waste from agricultural operations.

Landfill: A disposal facility or part of a facility where solid waste is placed in or on land, and which is not a land treatment facility, a surface impoundment, or an injection well.

Litter: means any unsecured or inadequately secured and improperly stored or disposed solid waste placed, thrown, dropped, deposited, blown, leaked or in any other manner distributed as prohibited by the provisions of this article.

Modify or modification: Any change to a solid waste management facility or change in the status of that facility that:

- (1) Is considered a modification (major or minor) by DHEC; or
- (2) Requires a modification of any kind to the facility's operating permit issued by DHEC; or
- (3) Involves construction, renovation and/or other changes to existing buildings, structures or units, other than normal daily operating changes; or
- (4) Results in a different classification, designation and/or use for a solid waste management facility or composting facility; or
- (5) Results in a change of ownership and/or operation of a solid waste management facility or composting facility; or
- (6) Results in any addition and/or deletion of a waste stream for a significant user of a solid waste management facility or composting facility.

Municipal solid waste. Any solid waste (including garbage, trash, and sanitary waste in septic tanks) derived from households (including single and multiple residences, hotels and motels, bunkhouses, ranger stations, crew quarters, campgrounds, picnic grounds, and day-use recreation areas), generated by commercial establishments (stores, offices, restaurants, warehouses, and other nonmanufacturing activities, excluding industrial facilities) and nonhazardous sludge.

Owner/operator: The person who owns the land on which a solid waste management facility or composting facility is located or the person who is responsible for the overall operation of the facility, or both.

Person: An individual, partnership, copartnership, cooperative, association, firm, company, public or private corporation, political subdivision, agency of the state, agency of the federal government, trust, estate, joint structure company or any other legal entity or its legal representative, agent or assigns.

Pickup truck: A motor truck with a manufacturer's gross vehicle weight rating of less than 11,500 pounds, an unladen weight of less than 8,001 pounds, and which is equipped with an open box-type bed less than nine feet in length. Pickup truck does not include a motor vehicle, otherwise meeting the above definition that is equipped with a bed-mounted storage compartment commonly called a utility body.

Primary residence: Residential dwelling unit that is occupied by the owner or renter of such unit. For purposes of this chapter, owners and renters shall designate only one primary residence.

Recovered materials: Materials which have known use, reuse, or recycling potential; can be feasibly used, reused, or recycled; and have been diverted or removed from the solid waste stream for sale, use, reuse, or recycling, whether or not requiring subsequent separation and processing.

Recovered Materials Processing Facility: A facility engaged solely in the recycling, storage, processing, and resale or reuse of recovered materials.

Recyclable material: Those materials which would otherwise become municipal solid waste, and which can be collected, separated or processed and returned to the economic mainstream in the form of raw materials or products.

Recycling: Any process by which materials which would otherwise become solid waste are collected, separated, or processed and reused or returned to use in the form of raw materials or products (including composting).

Residential property: Property that contains one or more residential dwelling units other than those defined as apartments.

Residential solid waste: Any and all accumulations of municipal solid waste (including unrecovered recyclable materials) generated by single-family residential units or multifamily residential facilities where aggregate municipal solid waste collection is not provided to the tenant as part of a rental agreement.

Reuse: The return of a commodity into the economic stream for use in the same kind of application as before without change in its identity.

Roll cart: Containers, mounted on wheels, which are used to store residential solid waste or recovered materials between collections by collectors.

Single-family residential unit: Residential properties classified by the county assessor as having only one dwelling unit per property or parcel.

Solid waste management plan: The local solid waste management plan that must be developed and implemented by each county pursuant to S.C. Code § 44-96-80.

Solid waste: Garbage, municipal solid waste, or sludge from a waste treatment facility, water supply plant, or air pollution control facility and other discarded material, including solid, liquid, semi-solid, or contained gaseous material resulting from industrial, commercial, mining, and agricultural operations and from community activities.

This term does not include solid or dissolved material in domestic sewage, recovered materials, or solid or dissolved materials in irrigation return flows or industrial discharges which are point sources subject to NPDES permits under the Federal Water Pollution Control Act, as amended, or the Pollution Control Act of South Carolina, as amended, or source, special nuclear, or by-product material as defined by the Atomic Energy Act of 1964, as amended. Also excluded from this definition are application of fertilizer and animal manure during normal agricultural operations or municipal solid waste as defined and regulated pursuant to the South Carolina Mining Act, including processed mineral waste, which will not have a significant adverse impact on the environment.

Solid waste management facility: Any solid waste disposal area (including public and private landfills), volume reduction plant; transfer station, collection center, or other facility, the purpose of which is the storage, collection, transportation, treatment, utilization, processing, recycling, or disposal, or any combination thereof, of solid waste. For purposes of this chapter, this term does not include composting facilities, or noncommercial industrial facilities managing solid waste generated in the course of normal operations on property under the same ownership or control as the waste management facility.

Source reduction: The reduction of solid waste before it enters the solid waste stream by methods such as product redesign or reduced packaging.

Transfer station: Any permitted temporary holding site for the collection and transfer of solid waste from private citizens and by collector/haulers and commercial collector/haulers to a disposal facility.

Vector: A carrier that is capable of transmitting a pathogen from one organism to another including, but not limited to, flies and other insects, rodents, birds and vermin.

Vehicle: Any device capable of being moved upon a public highway or roadway and in, upon or by which any person or property is or shall be transported or drawn upon a public highway or roadway.

Yard waste: Any and all accumulations of grass, leaves, pine straw, small trees and branches, shrubs, vines and other similar items of less than six inches in diameter, four feet in length generated by the typical maintenance of lawns, shrubs, gardens and trees from residential properties. Yard waste shall not be commingled with garbage or solid waste.

Weeds and rank vegetation: Dense, uncultivated, herbaceous overgrowth over two feet in height, or briars and trailing vines exceeding ten feet in length.

White goods: Includes refrigerators, ranges, water heaters, freezers, dishwashers, residential trash compactors, dryers, air conditioners, and other large appliances.

(Ord. No. 2007/37, 10-22-2007)

Sec. 62-4. Enforcement.

- (1) The Department of Public Works Office of Solid Waste and Recycling , County Code Enforcement Officers, and other law enforcement agencies shall be charged with the enforcement of this section and shall be authorized to obtain for their personnel such law enforcement commissions as may be necessary. Litter control officers, any commissioned law enforcement officer and appointed code enforcement officers shall have the authority to enforce the provisions of this ~~section~~ chapter and may issue a summons to any violator to appear in the magistrate's court of the county to answer the charge of violation of this ~~section~~ chapter.
- (2) If any solid waste improperly or unlawfully disposed of in violation of this chapter can be identified as having last belonged to, been in the possession of, sent to, or received by, or to have been the property of any person prior to its being disposed of as prohibited herein, such identification shall be presumed to be prima facie evidence that such person disposed of or caused to be disposed of such solid waste in violation of this chapter.

- (3) Proof of means used for proper disposal of solid wastes at businesses and commercial enterprises shall be presented to the law enforcement officers or code enforcement officers when requested by the officer.
- (4) Responsibility for the removal of litter from property or receptacles is upon the person convicted pursuant to this section of littering the property or receptacles. If there is no conviction for littering, the responsibility is upon the owner of the property.

(Ord. No. 2007/37, 10-22-2007)

Sec. 62-5. Penalties.

- (a) ~~A person, from a vehicle or otherwise, shall not dump, throw, drop, deposit, discard, or otherwise dispose of litter or other solid waste, as defined by S.C. § 44-96-40(46), upon public or private property or waters in the state including, but not limited to, a highway, park, beach, campground, forest land, recreational area, trailer park, road, street, or alley except:~~
- (1) ~~On property designated by the state for the disposal of litter and other solid waste and the person is authorized to use the property for that purpose; or~~
- (2) ~~Into a litter receptacle in a manner that the litter is prevented from being carried away or deposited by the elements upon a part of the private or public property or waters.~~
- (b) ~~Responsibility for the removal of litter from property or receptacles is upon the person convicted pursuant to this section of littering the property or receptacles. If there is no conviction for littering, the responsibility is upon the owner of the property.~~
- (c) (1) A person who willfully violates the provisions of this ~~section~~ chapter is guilty of a misdemeanor and, upon conviction, shall be fined not more than \$500.00~~\$200.00~~ or imprisoned for not more than 30 days, or both. ~~for a first or second conviction, or shall be fined \$500.00 or imprisoned for not more than 30 days, or both for a third second or subsequent conviction. In addition to the fine or term of imprisonment, the court also must impose eight hours of litter-gathering labor for a first conviction, 16 hours of litter-gathering labor for a second conviction, and 24 hours of litter-gathering labor for a third or subsequent conviction, or other form of public service, under the supervision of the court, as the court may order because of physical or other incapacities.~~
- (2) ~~The fine for a deposit of a collection of litter or solid waste in an area or facility not intended for public deposit of litter or solid waste is \$1,000.00. The provisions of this item apply to a deposit of litter or solid waste, as defined in S.C. § 44-67-30 (4), in an area or facility not intended for public deposit of litter or solid waste. This item does not prohibit a private property owner from depositing litter or solid waste as a property enhancement if the depositing does not violate applicable local or state health and safety regulations. In addition to a fine and for each offense pursuant to the provisions of this item, the court also shall impose a minimum of five hours of litter-gathering labor or other form of public service, under the supervision of the court, as the court may order because of physical or other incapacities.~~
- (3)(2) ~~The court, instead of payment of the monetary fine imposed for a violation of this sectionchapter, may direct the substitution of additional litter-gathering labor or other form of public service, under the supervision of the court, as it may order because of physical or other incapacities not to exceed one hour for each \$5.00 \$25.00 of fine imposed.~~
- (4)(3) ~~In addition to other punishment authorized by this section, in the discretion of the court in which conviction is obtained, the person may be directed by the judge to pick up and remove from any public place or any private property, with prior permission of the legal owner of the property upon~~

which it is established by competent evidence that the person has deposited litter, all litter deposited on the place or property by any person before the date of execution of sentence.

- (d)(b) — In cases in which a person who violates the provisions of this section in an amount exceeding 15 pounds in weight or 27 cubic feet in volume, but not exceeding 500 pounds or 100 cubic feet, is guilty of a misdemeanor and, upon conviction, shall be fined not less than \$200.00 nor more than \$500.00 or imprisoned for not more than 90 days. In addition, the court shall require the violator to pick up litter or perform other community service commensurate with the offense committed, up to 100 hours.
- (e) (1) A person who violates the provisions of this section in an amount exceeding 50 pounds in weight or 100 cubic feet in volume is guilty of a misdemeanor and, upon conviction, shall be fined not less than \$500.00 or more than \$1,000.00, or imprisoned not more than one year, or both. In addition, the court may order the violator to:
- a. — Remove or render harmless the litter that he dumped in violation of this subsection;
 - b. — Repair or restore property damaged by, or pay damages for damage arising out of, his dumping of litter in violation of this subsection; or
 - c. — Perform community public service relating to the removal of litter dumped in violation of this subsection or relating to the restoration of an area polluted by litter dumped in violation of this subsection.
- (2) — A court may enjoin a violation of this subsection.
- (3) — A motor vehicle, vessel, aircraft, container, crane, winch, or machine involved in the disposal of more than 500 pounds in weight or more than 100 cubic feet in volume of litter in violation of this subsection is declared contraband and is subject to seizure and summary forfeiture to the state.
- (4) — If a person sustains damages in connection with a violation of this subsection that gives rise to a felony against the person or his property, a court, in a civil action for those damages, shall order the wrongdoer to pay the injured party threefold the actual damages or \$200.00, whichever amount is greater. In addition, the court shall order the wrongdoer to pay the injured party's court costs and attorney's fees.
- (5) — A fine imposed pursuant to this subsection shall not be suspended, in whole or in part.
- (f) (1) — When the penalty for a violation of this section includes litter gathering labor in addition to a fine or imprisonment, the litter gathering portion of the penalty is mandatory and shall not be suspended; however, the court, upon the request of a person convicted of violating this section, may direct that the person pay an additional monetary penalty instead of the litter gathering portion of the penalty that must be equal to the amount of \$5.00 an hour of litter gathering labor. Probation shall not be granted instead of the litter gathering requirement, except for a person's physical or other incapacities.
- (2) — Funds collected pursuant to this subsection instead of the mandatory litter gathering labor shall be remitted to the county or municipality where the littering violation took place. The money collected may be used for the litter gathering supervision.
- (g) — For purposes of the offenses established by this section, litter includes cigarettes and cigarette filters.
- (h) — A prior violation within the meaning of this section means only a violation of this section which occurred within a period of five years including and immediately preceding the date of the last violation.
- (i) — Magistrates and municipal courts have jurisdiction to try violations of subsections (a), (b), (c), and (d) of this section.

(Ord. No. 2007/37, 10-22-2007)

Sec. 62-6. Uniform service charges.

- (a) The county council shall impose millage as part of its annual budget process to fund the solid waste and recycling enterprise system. At any point in the future, county council may, by ordinance, impose uniform service charges, and rates fees, and charges. The proceeds from the millage, uniform service charges, and rates, fees and charges established by county council shall be used to pay in whole or in part the costs of acquiring, equipping, operating, and maintaining facilities and services for the collection, transportation, storage, handling, separation, treatment, reduction, recycling, reuse, and disposal of residential solid waste generated within the county.
- (b) If imposed, there shall be a uniform residential solid waste fee annually imposed upon the owner of record of each residence in the county, including all single and multi-family homes, mobile homes, and all lease and rental properties, in accordance with the then prevailing fee schedule, subject to the rules and regulations governing the solid waste and recycling enterprise system, and further subject to any applicable exemptions, which exemptions shall include, but not be limited to, a complete or partial exemption for users in any municipality within the county to the extent the respective municipality provides a service in lieu of the county. In addition to fees, charges, and rates with respect to solid waste and recycling facilities and services, fees, charges, and rates in connection with other solid waste and recycling facilities and services may be imposed within the corporate limits of a municipality in the county by contract with an individual, corporation, or municipal governing body to the extent the county is providing solid waste and recycling services in a municipality pursuant to subsection 62-1(b).

Residential solid waste fees, if imposed, shall be levied as a uniform assessment by the county auditor and placed upon the annual real estate tax notice and collected by the county treasurer, pursuant to state law. The fiscal officers of the county shall have the authority to nulla bona or abate these fees to the same extent and under the same conditions as they do for a comparable tax.

- (c) Further, if residential solid waste charges are imposed, there shall be imposed a late fee and supplemental processing charge, for all solid waste fees not timely remitted to the county treasurer by March 16 of the year when due. For all past due accounts in excess of one year, the county shall impose an additional annual penalty. The county shall pursue all legal remedies available to it to recover past due amounts, and shall hold the property owner or record responsible for all costs of collection, including reasonable attorney fees, as a part of such collection efforts and as a part of the fees imposed by county council pursuant to state law, in order that lawful tax-paying citizens not be forced to subsidize those taxpayers who do not pay this lawful fee in a timely manner.

(Ord. No. 2020/19, § 2.C, 6-8-2020; Ord. No. 2021/24, § 2.C, 5-24-2021)

Sec. 62-7. Special fund.

All taxes, charges, rates, fees, or other revenues collected pursuant to this chapter shall be deposited to a special fund to be known as the solid waste and recycling enterprise fund, and all funds deposited in the solid waste and recycling enterprise fund shall be expended for the administration, operation, and maintenance of the county solid waste and recycling programs and the acquiring, constructing, renovating, and equipping of apparatus and facilities necessary or convenient therefor. Should the county issue bonds or enter into other obligations the proceeds of which benefit the solid waste and recycling enterprise system, it may secure such bonds and other obligations with a pledge of all or a portion of the revenues deposited to or derived from the solid waste and recycling enterprise fund. Nothing shall prohibit the creation of sub-funds or accounts as may be necessary or appropriate.

(Ord. No. 2020/19, § 2.D, 6-8-2020; Ord. No. 2021/24, § 2.D, 5-24-2021)

Sec. 62-8. Severability.

If any section, subsection, or clause of this chapter shall be deemed unconstitutional or otherwise invalid, the validity of the remaining sections, subsections, and clauses shall not be affected thereby.

Secs. 62-9 to 62-19 ~~8-62-9~~. Reserved.

Move this Article II to Chapter 38 as a more appropriate location to address this.

~~ARTICLE II. LITTERING, SCAVENGING, AND PROPERTY MAINTENANCE~~**~~Sec. 62-10. Littering on or along public rights of way prohibited.~~**

- (1) ~~It shall be unlawful for any person to throw, drop, leave, or in any way to intentionally or unintentionally deposit or dispose of litter on any property or on or along any street, road, highway, curb, sidewalk, or public right-of-way, except as required by the authorized and franchise municipal solid waste collector for that district; nor shall any person throw or deposit any litter in any stream or other body of water within the boundaries of the county.~~
- (2) ~~Furthermore, when litter is thrown, blown or allowed to escape from a vehicle, if the identity of the driver cannot be determined, the operator and/or the owner of the vehicle shall be held responsible even when the operator or owner did not throw the litter out or allow the litter to escape.~~
- (3) ~~Responsibility for the immediate removal and proper disposal of litter from property is upon the person convicted under this chapter of littering. However, if there is no conviction, the responsibility for removal and proper disposal shall be upon the owner and/or occupant of the property where the litter was deposited.~~

~~(Ord. No. 2007/37, 10-22-2007)~~

~~Sec. 62-11. Scavenging at county solid waste management facilities.~~

~~It shall be unlawful for any person to rummage through, remove, salvage items or otherwise scavenge from county-operated or private solid waste management facilities to include solid waste collection and storage containers. A summons may be issued to any violator to appear in the magistrate's court of the county to answer the charge of violation of this section.~~

~~(Ord. No. 2007/37, 10-22-2007)~~

~~Sec. 62-12. Solid waste on lots.~~

- (1) ~~[Unlawful disposal or accumulation.] It shall be unlawful for any person to dispose of or cause to be disposed of or allow to accumulate, or for any property owner to allow any person to dispose of or cause to be disposed of or cause to accumulate any type of solid waste anywhere in the county except at a solid waste~~

management facility that has been approved by county council and/or the South Carolina DHEC or as otherwise provided for under article III of this chapter.

- (2) ~~*Declaration of nuisance.*~~ Solid waste allowed to accumulate and remain on any lot or parcel of land in the county may be deemed and declared a nuisance in the judgment of the county administrator.
- (3) ~~*Duties of owner, etc.*~~ It shall be the duty of any owner, lessee, occupant, agent, or representative of the owner of any lot or parcel of land in the county to remove and properly dispose of such solid waste as often as may be necessary to prevent the accumulation of such waste. Furthermore, it shall be the responsibility of the owner, lessee, occupant, agent, or representative of the owner to limit access to said property such that indiscriminate disposal of solid waste is minimized.
- (4) ~~*Notice to owner, etc., to remove.*~~ Whenever the county administrator shall find that solid waste has been allowed to accumulate and remain upon any lot or parcel of land in the county in such a manner as to constitute a nuisance, the county administrator may serve written notice upon the owner, or the occupant of the premises, or upon the agent or representative of the owner of such land having control thereof to comply with the provisions of this chapter. It shall be sufficient notification to personally deliver the notice to the owner (or occupant or agent), or to deposit a copy of such in the United States mail, properly stamped, and directed to the owner (or occupant or agent) at his/her address of record, or to post a copy of the notice upon such premises.
- (5) ~~*Failure to comply with notice.*~~ If the person to whom the notice is directed, under the provisions of the preceding subsection fails or neglects to cause such solid waste to be removed from any such premises and properly disposed of within ten days after such notice has been served or deposited in the United States mail, or posted upon premises, such person shall be deemed guilty of a misdemeanor and subject to the penalty provisions of this chapter.
- (6) ~~*Removal by county.*~~ In the event any property is determined to be a nuisance, and 20 days has elapsed after such notice has been served, deposited in the United States mail, or posted upon the premises, then the county administrator may enter upon any such property and abate such nuisance by removing and disposing of the solid waste, and the cost of doing so may become a lien upon the property affected, or may be recovered by the county through judgment proceedings initiated in a court of competent jurisdiction.
- (7) ~~*Work may be done by county upon request.*~~ Upon the written request to the county administrator by the owner or the person in control of any lot or parcel of land subject to the provisions of this section and payment to the county for the services consistent with the overgrowth cleanup fee structure, the county administrator or his/her designated contractor may enter onto such land and perform such cleanup activities as necessary to remove and properly dispose of the solid waste thereon.
- (8) ~~*Solid waste on lots cleanup fee structure.*~~ A fee schedule and any amendments thereto for disposal of solid waste resulting from cleanup of such waste on lots shall be developed and approved by the county administrator.

(Ord. No. 2007/37, 10-22-2007)

Sec. 62-13. Unlawful acts.

- (1) It shall be unlawful to dispose of broken or whole bricks, broken or whole blocks, or cured/uncured concrete, land clearing debris or another other type of solid waste anywhere in the unincorporated area of the county except at landfills permitted by the state under regulations R.61-107.11, Part IV, R.61-107.16 or R.61-107.258 and permitted consistent with the provisions of Sec. 62-46 of this chapter. Responsibility for the immediate removal and proper disposal of such waste from property is upon the person convicted under this chapter. However, if there is no conviction, the responsibility for removal and proper disposal shall be upon the owner and/or occupant of the property where the waste was deposited.

(2) Organized collection, e.g., green boxes, etc., of solid waste shall be at a frequency which ensures the prevention of hazards and nuisances to human health and the environment. It shall be unlawful for the owner(s) of such container(s) to fail to pick up and properly dispose of the waste therein at a frequency that exceeds seven calendar days.

(Ord. No. 2007/37, 10-22-2007)

Sec. 62-14. Weeds and rank vegetation.

(1) *Declaration of nuisance.* Any residential lot/parcel or any nonresidential lot/parcel located contiguous to a residential lot in the county that becomes substantially overgrown with weeds and rank vegetation such that it poses potential safety risks to humans and/or becomes a harborage for vectors may be deemed and declared a nuisance in the judgment of the county administrator.

(2) *Duties of owner, etc.* It shall be the duty of any owner, lessee, occupant, agent, or representative of the owner of any residential lot/parcel or any nonresidential lot/parcel located contiguous to a residential lot in the county to cut, trim and remove for proper disposal such weeds and rank vegetation as often as may be necessary to prevent the growth of such weeds and rank vegetation that shall constitute a nuisance. However, lots of three acres or more shall only be required to cut 100 feet from contiguous road(s) and each side property line.

(3) *Notice to owner, etc., to remove.* Whenever the county administrator shall find that overgrowth of weeds and rank vegetation on a residential lot/parcel or any nonresidential lot/parcel located contiguous to a residential lot in the county constitutes a nuisance, the county administrator may serve written notice upon the owner, or the occupant of the premises, or upon the agent or representative of the owner of such land having control thereof to comply with the provisions of this section. It shall be sufficient notification to personally deliver the notice to the owner (or occupant or agent), or to deposit a copy of such in the United States mail, properly stamped, and directed to the owner (or occupant or agent) at his/her address of record, or to post a copy of the notice upon such premises.

(4) *Failure to comply with notice.* If the person to whom the notice is directed, under the provisions of the preceding subsection fails or neglects to cause such overgrowth of weeds and rank vegetation to be removed from any such premises and properly disposed of within ten days after such notice has been served or deposited in the United States mail, or posted upon premises, such person shall be deemed guilty of a misdemeanor and subject to the penalty provisions of this chapter.

(5) *Removal by county.* In the event any overgrowth of weeds and rank vegetation is determined to be a nuisance, and twenty (20) days has elapsed after such notice has been served, deposited in the United States mail, or posted upon the premises, then the county administrator or his/her designated contractor may enter upon any such property and abate such nuisance by cutting, trimming, removing and disposing of the vegetative waste, and the cost of doing so, pursuant to the cleanup fee structure noted below, may become a lien upon the property affected, or may be recovered by the county through judgment proceedings initiated in a court of competent jurisdiction.

(6) *Work may be done by county upon request.* Upon the written request to the county administrator by the owner or the person in control of any lot or parcel of land subject to the provisions of this section and payment to the county for the services consistent with the overgrowth cleanup fee structure, the county administrator or his/her designated contractor may enter onto such land and perform such cleanup activities as necessary to remove and properly dispose of the weeds and rank vegetation thereon.

(h) *Overgrowth cleanup fee structure.* A fee schedule and any amendments thereto for necessary or requested cleanup and disposal of waste resulting from cleanup of nuisance overgrowth of weeds and rank vegetation on lots shall be developed and approved by the county administrator.

(Ord. No. 2007/37, 10-22-2007)

~~Secs. 62-15~~

~~Secs. 62-16 — 62-19. Reserved.~~

**ARTICLE ~~III~~ II. COLLECTION, TRANSPORTATION, AND DISPOSAL OF MUNICIPAL
SOLID WASTE**

Sec. 62-20. Applicability.

This article shall apply to the preparation, storage, collection, transportation and disposal of all municipal solid waste in the area under jurisdiction of the county council as presently or hereafter established. It shall prescribe rules and regulations relating to collection and disposal of municipal solid waste; prescribing rules and regulations for hauling municipal solid waste within and through the county; providing for the proper disposal of municipal solid waste; and prohibiting the spilling of loads within the county.

(Ord. No. 2007/37, 10-22-2007)

Sec. 62-21. Establishment of solid waste districts.

- (1) Beaufort County shall be divided into nine solid waste districts. They shall be designated numerically as follows:
 - (a) District 1, City of Beaufort. All of the area within the boundaries of that incorporated city. Includes Tax District 120.
 - (b) District 2, Town of Port Royal. All of the area within the boundaries of that incorporated town. Includes Tax District 110.
 - (c) District 3, Town of Hilton Head Island. All of the area within the boundaries of that incorporated town and Jenkins Island and Pinckney Island. Includes Tax Districts 500, 501, 510, 520, 530, 540, 541 and 550.
 - (d) District 4, Town of Bluffton. All of the area within the boundaries of that incorporated town. Includes Tax District 610.
 - (e) District 5, Sheldon Township. All of the area within Beaufort County which is on the north side of the Whale Branch River. This includes the Beaufort County portion of the Town of Yemassee. Includes Tax Districts 700 and 710.
 - (f) District 6, Unincorporated Port Royal Island (Burton). All of the area between the Whale Branch River, the Beaufort River, and the Broad River exclusive of previously listed incorporated areas. Includes Tax District 100.
 - (g) District 7, Lady's Island. All of the area between the Beaufort River and Chowan Creek including Coosaw Island exclusive of the City of Beaufort. Includes Tax District 200.
 - (h) District 8, Saint Helena Island and Islands East. All of the area and islands east of Chowan Creek within Beaufort County. Includes Tax Districts 300 and 400.
 - (i) District 9, Bluffton Township. All of the area south of the Broad River and west of Pinckney Island exclusive of the Town of Bluffton and Daufuskie Island. Includes Tax District 600.

Created: 2022-06-21 16:57:26 [EST]

(Supp. No. 47, Update 4)

- (j) Because of the remote nature of Daufuskie Island, the minimum level of solid waste services differs from that in other solid waste districts in the county. Recovered materials are not collected by the county on Daufuskie Island.

Note(s)—Solid waste collection, transportation and disposal from Daufuskie Island generated outside of the planned unit developments (PUDs) shall be paid for from the county general fund.

- (2) Solid waste districts are established in order to track expenditures for all publicly provided solid waste and recycling services within that district. Solid waste and recycling services include the collection, transportation, processing or disposal of solid waste or recovered material. Collection methods may vary between districts depending upon demographics, population or other factors.
- (3) Solid waste districts 1, 2, 3 and 4 shall be administered through intergovernmental agreements between the Beaufort County Council and the City Council of Beaufort, the Town Council of Port Royal, the Town Council of Hilton Head Island and the Town Council of Bluffton respectively. Solid waste districts 5, 6, 7, 8 and 9 shall be collectively administered by the county administrator.

(Ord. No. 2007/37, 10-22-2007)

Sec. 62-22. Residential solid waste and recovered materials collection

- (1) Municipal solid waste and recovered materials shall be collected from single-family county residences by roll-cart service and/or bin service only by:
- Collectors who are licensed by the county.
 - Licensed collectors who are franchised by the county for collection in specific areas of the county.
 - Licensed collectors under contract with a municipality to provide curbside service.
 - Municipal collectors in an incorporated solid waste district.
 - County collectors in an unincorporated solid waste district.
- (2) Collectors providing curbside collection of residential solid waste shall provide curbside collection of recovered materials to same residential properties. Failure to provide collection of recovered materials shall be cause for suspension of the collector's license.
- (3) Collectors shall deliver collected recovered materials to a recovered materials processing facility. Disposal of collected recovered material in any other manner, without written permission from the county administrator, is deemed as illegal dumping and shall be prosecuted subject to the penalties in section 62-5.
- (4) Collection and disposal of municipal solid waste and/or discarded materials resulting from evictions shall be the responsibility of the property owner or his/her designated agent. Municipal solid waste and/or discarded materials resulting from evictions shall not be placed within 25 feet of any curbside.

(Ord. No. 2007/37, 10-22-2007)

Sec. 62-23. Preparation and storage of residential solid waste and recovered materials for collection.

- (1) It shall be the duty of the occupant or owner of any residential property to store all solid waste and recovered materials properly prior to collection by the county or its contractor or licensed hauler..
- (2) All solid waste and recovered material containers shall be kept clean and free of accumulated waste.

(Supp. No. 47, Update 4)

Created: 2022-06-21 16:57:26 [EST]

- (3) Each property owner shall prevent the continued, excessive, and unsightly accumulations of solid waste upon the property he and/or she owns.
- (4) No person shall place or cause to be placed in any municipal solid waste or recovered material container for collection any acid, explosive material, flammable liquid, or dangerous or corrosive material of any kind, or any other hazardous waste beyond household quantities of household hazardous wastes.
- (5) No person other than the owner thereof, his or her agents or employees, or employees of licensed haulers or contractors of the county for the collection of municipal solid waste or recovered materials shall tamper or meddle with any municipal solid waste or recovered materials container or the contents thereof or remove the contents of the container from the location where the same shall have been placed by the owner thereof or his agents.
- (6) Property owners shall be prohibited from receiving for deposit in their municipal solid waste containers any type municipal solid waste that originates outside of their designated collection area.
- (7) Property owners shall be responsible for policing any litter resulting from municipal solid waste or recovered materials not properly prepared for collection or from any other cause other than mishandling by the contractor or licensed hauler.

(Ord. No. 2007/37, 10-22-2007)

Sec. 62-24. Transporting loads of solid waste or recovered materials.

- (1) No person shall operate on any public highway or roadway in the county any vehicle with any load of solid waste or recovered materials unless such load and any covering thereon is securely fastened so as to prevent such covering or load from becoming loose, detached or in any manner a hazard to other users of the highway or roadway.
- (2) No vehicle may be driven or moved on any public highway or roadway in the county unless the vehicle is so constructed or loaded with solid waste or recovered material as to prevent any of its load from dropping, sifting, leaking, or otherwise escaping from the vehicle, except that sand, salt, or other chemicals may be dropped for the purpose of securing traction, and water or other substance may be sprinkled on a highway in the cleaning or maintaining of the highway by the public authority having jurisdiction.
- (3) Trucks, trailers, or other vehicles when loaded with rock, gravel, stone, metals, or other similar substances which could blow, leak, sift, or drop shall not be driven or moved on any public highway or roadway in the county unless the height of the load against all four walls does not extend above a horizontal line six inches below their tops when loaded at the loading point; or, if the load is not level, unless the height of the sides of the load against all four walls does not extend above a horizontal line six inches below their tops, and the highest point of the load does not extend above their tops, when loaded at the loading point; or, if not so loaded, unless the load is securely covered by tarpaulin or some other suitable covering; or unless it is otherwise constructed so as to prevent any of its load from dropping, sifting, leaking, blowing, or otherwise escaping from the vehicle.
- (4) Proof of litter, as defined herein, escaping from a vehicle shall not be necessary to be in violation of the requirements of this section.
- ~~(5) Violations of this section shall be prosecuted subject to penalties prescribed by South Carolina law.~~

(Ord. No. 2007/37, 10-22-2007)

Sec. 62-25. Items not covered in residential solid waste collection service.

- (1) *Dead animals.* Disposal of dead animals or household pets shall be the responsibility of the animal owner.
- (2) *Construction and demolition (C&D) debris.* The county shall not be responsible for collection or disposal of construction and demolition debris when quantities exceed household quantities.
- (3) *Industrial and hazardous waste.* The county shall not be responsible for collection or disposal of discarded industrial and/or hazardous waste except when such wastes are household quantities of household hazardous waste.
- (4) *Waste generated by commercial tree or yard contractor activities.* Waste from commercial tree cutters and surgeons shall be properly disposed of by the person performing the work or by the owner who engaged that person at their expense.

(Ord. No. 2007/37, 10-22-2007)

Sec. 62-26. Collected municipal solid waste is county property.

- (a) All municipal solid waste collected by county forces or franchised collectors shall be disposed of and/or delivered to such places and used for such purposes as may be ordered by the county administrator.
- (b) The County may request that franchised collectors provide evidence/proof that all municipal solid waste collected as residential solid waste originated from Beaufort County residents.

(Ord. No. 2007/37, 10-22-2007)

Sec. 62-27. Revenue for solid waste and recycling services.

- (a) All required Beaufort County solid waste and recycling revenue shall be generated through a combination of property tax millage, other fees as may be approved by the county council, reimbursement by federal government organizations and the sale of recovered materials.
- (b) Municipal governments which choose to provide collection or recycling services may fund their programs through appropriate municipal fees or taxes or a combination thereof.
- (c) A fee schedule, and any amendments thereto, for disposal of waste or handling of waste at any county-operated solid waste management facility, to include but not be limited to county collection centers or transfer stations shall be developed and approved by the county administrator.
- (d) Residents may deliver to collection centers household quantities of construction, demolition and land-clearing debris and other solid wastes as allowed in the receiving facility's operating permit, which are generated from his/her primary residence.
- (e) Rental and investment properties are considered commercial. Therefore, owners of such property will pay the disposal fee for solid waste originating from such properties.

(Ord. No. 2007/37, 10-22-2007)

Sec. 62-28. County facility acceptance of solid waste generated outside county.

- (1) All solid waste generated from outside the boundaries of the county are banned from being disposed of in any county-operated facility.

- (2) The term "generated," as used in this section, shall relate to the point of origin of the solid waste.
- (3) The county administrator is hereby authorized to implement such programs and procedures as deemed necessary to further implement this ban; to inspect all loads designated for any county facility for any violations thereof; and to issue warrants according to law for any violations of this section.
- (4) Any person bringing waste to any county facility shall, on request, sign a statement authenticating that said solid waste was generated within the county.
- ~~(5) Any residential solid waste collector found in violation of this section by the county shall forfeit their license to collect/haul solid waste within Beaufort County.~~
- (65) Any dispute as to the point of origin of the solid waste shall be resolved by the county administrator.
- (76) Any and each false statement signed by a person disposing of solid waste referred to in subsection (4) of this section shall constitute a violation of this chapter.
- (87) The county administrator may seek an injunction to enforce the provisions of this section.

(Ord. No. 2007/37, 10-22-2007)

Sec. 62-29. Use of county-operated collection centers.

- (1) It shall be a violation of this chapter for any person to:
 - (a) Fail to comply with directions for proper disposal that are given by county personnel charged with the operation of county solid waste management facilities.
 - (b) Exhibit disruptive or abusive conduct towards county personnel or other patrons at county-operated solid waste management facilities.
 - (c) Dispose of unauthorized solid waste at county-operated solid waste management facilities. Out-of-county generated solid waste shall be included as an unauthorized solid waste.
- (2) In addition to the penalty provisions of this chapter, the county administrator may ban any person who violates any requirement of this section from the use of county-operated solid waste management facilities for indefinite periods of time.

(Ord. No. 2007/37, 10-22-2007)

Sec. 62 - 30 Scavenging at county solid waste management facilities prohibited. (moved from 62-11)

It shall be unlawful for any person to rummage through, remove, salvage items or otherwise scavenge from county-operated or private solid waste management facilities to include solid waste collection and storage containers. A summons may be issued to any violator to appear in the magistrate's court of the county to answer the charge of violation of this section.

Sec. 62-30 31. Collection centers.

- (a) The county administrator is empowered and directed to establish procedures and guidelines for the efficient and safe operation of county collection centers.
- (b) No commercial waste shall be accepted at the collection centers. Any commercial waste dumped at collection centers shall be treated as illegal dumping and subject to enforcement actions as specified by South Carolina Law.

(Supp. No. 47, Update 4)

Created: 2022-06-21 16:57:26 [EST]

- (c) Allowable truck/trailer loads for disposal at collection centers are defined as follows:
- (1) No trucks larger than a pickup or utility trailer (eight feet long, five feet wide, 28 inches or less inside height) are allowed at the collection centers.
 - (2) No loaded pickups with loaded trailers are allowed at the collection centers.
 - (3) A truck load is a load at or below the 28 inches side height of the pickup/trailer; no over-the-bed loads are allowed at the collection centers.
 - (4) No commercial trucks may use the collection centers for solid waste disposal except as described in subsection (g) of this section.
- (d) A ten-gallon per visit limit for oil disposal is established for the collection centers.
- (e) A four-tire per visit disposal limit for residents is established for the collection centers and the landfill.
- (f) No tires on rims shall be accepted at collection centers.
- (g) Residents driving commercial vehicles may bring one fifty-gallon trash bag or two thirty-gallon tall kitchen bags or less at a time into a collection center. Larger loads must be taken to the landfill and shall be treated as commercial waste.
- (h) Hours and days of operation at collection centers shall be posted at the sites and all changes to such hours or days (except in emergency situations) shall be posted/advertised prior to the effective date of the change.
- (Ord. No. 2007/37, 10-22-2007)

Sec. 62- 32. Collector/hauler licenses.

- (a) Collectors/haulers of solid waste shall dispose of all such waste at a DHEC approved landfill, with the exception of items specifically prohibited from such facilities which should be disposed at facilities permitted to take such items.
- (b) All privately operated solid waste collectors operating within Beaufort County shall be required to possess a collector/hauler license and a vehicle permits for each of the vehicles in their fleet traveling within the county. The collector/hauler license and vehicle permits shall be issued by the county administrator. Collector/hauler licenses and vehicle permits shall remain in effect from issuance to a period ending on June 30 annually for up to 12 months. **Operating in Beaufort County without a collector/hauler license and a permit on each vehicle operating in the county is a misdemeanor, and violators shall be fined not less than \$500.00 and not more than \$1,000.00.**
- (c) All licensed collectors/haulers are required to report on a monthly basis to the county administrator, by solid waste district, the number of residential customers served and the tons of residential solid waste and recovered material collected. Reports of previous month activity are due by the close of business on the tenth business day of each month.
- (d) Under no circumstance shall licensed collectors/haulers mix loads of residential and commercial solid waste. Any licensed collector found in violation of this section by the county shall forfeit their license to collect/haul solid waste within Beaufort County.
- (e) Licensed solid waste haulers shall advertise and offer, at a minimum, a residential curbside recycling program to all of their residential customers, where not otherwise offered by the county or a municipal government.
- (f) Upon approval of an application for a license to collect municipal solid waste in the county, collectors/haulers shall be furnished a copy of the following information pertaining to solid waste in Beaufort County and the State of South Carolina:

- (1) This ordinance [Ord. No. 2007/37]; 2023/_____
- (2) Section 16-11-700 of the Code of Laws of South Carolina, 1976, as amended, regarding dumping trash or refuse on property of another or on highways, oceans or riverfronts, etc.
- (g) Collectors shall sign a written statement that they have received and read this ordinance [Ord. No. 2007/37], 2023/_____ rules and regulations and information in paragraph (c) and agree to abide by them.
- (h) The following fees shall accompany all applications for a collector/hauler license:
- (1) Annual license fee for collectors of residential, business, commercial or industrial MSW and recovered material:
- Initial vehicle charge: \$100.00
- Additional vehicle charge: \$50.00
- (i) All collectors/haulers shall be required as a condition of their license to offer recycling services for their business, commercial and industrial customers.
- (j) Any residential solid waste collector found to have committed repeated violations of this chapter by the County Administrator, in addition to being subject to prosecution for the violation, may have their license to collect/haul solid waste within Beaufort County revoked. A residential solid waste collector who has had their license to collect/haul solid waste revoked by the County Administrator may appeal the decision to County Council in writing within 15 days of such decision by the County Administrator.

(Ord. No. 2007/37, 10-22-2007)

Sec. 62-~~32~~ 33. Collectors'/haulers' vehicles.

- (a) All vehicles used to collect and haul solid waste or recovered materials in the county must meet the standard for solid waste hauling established by SCDOT.
- (b) All vehicles used to transport solid waste or recovered materials for a fee shall be owned and operated under the supervision of the collector/hauler holding a valid collectors/haulers license issued by the county. Every permitted vehicle shall display a current permit in the vehicle windshield.
- (c) Solid waste and recovered materials collection vehicles shall be kept in a clean and sanitary condition. No wastes shall be permitted to remain overnight anywhere in the vehicle body. The county administrator may inspect any collector/hauler vehicle at any time. If the vehicle is found to be unsanitary, the operator shall be required to steam-clean and deodorize the equipment at their expense.
- (d) All vehicles used for the collection and transportation of solid waste or recovered materials are to be so constructed, maintained, and operated to prevent liquid leakage and loss of materials in transit. The body of all vehicles that transport solid waste or recovered materials shall be wholly enclosed or shall be covered with a canvas cover or net with eyelets and rope tie-downs or any other approved method which will prevent blowing or spillage of the vehicle's contents.
- (e) All collectors/haulers shall furnish the county administrator a list identifying, by unique number or designator, all equipment to be used in the collection and transportation of solid waste or recovered materials.

(Ord. No. 2007/37, 10-22-2007)

Secs. 62-33 —Penalties**Secs. 62-34—62-41. Reserved.**

***ARTICLE IV-III. CONSTRUCTION, MODIFICATION, EXPANSION, AND/OR
OPERATION OF SOLID WASTE MANAGEMENT FACILITIES AND COMPOSTING
FACILITIES***

Sec. 62-42. Applicability.

- (1) This article applies to solid waste management facilities and composting facilities.
- (2) The following uses are exempt from the requirements of this article:
 - (a) Landfills used solely for disposal of industrial solid waste generated in the course of normal operations on property under the same ownership or control as the landfill.
 - (b) Land-clearing debris generated and disposed of on the same property.
 - (c) Backyard composting where the compost is produced from materials generated on-site.
 - (d) Agricultural operations where the compost is produced from materials generated on the owner's land.
 - (e) Mobile chipping/shredding equipment which chips/shreds wood waste, e.g., the type used by utilities to clear rights-of-way or manage storm debris, and which may spread the wood waste on rights-of-way after it has been chipped or shredded. Chipped and unchipped material related to this exemption shall not be stockpiled more than 90 days.
 - f. Temporary chipping/shredding and storage of wood waste for distribution to the public, e.g., grinding of the greens and other similar programs, as approved by the county council.
 - g. Shredding or chipping of untreated wooden pallets or other wooden packaging utilized by industry in its own operations that have not been in direct contact with hazardous constituents, e.g., petroleum products, pesticides, lead-based paint, etc.
 - h. Composting at industrial sites where the compost is produced from materials generated on properties under the same ownership or control within one-fourth mile of each other, unless otherwise approved by the county council and where the compost product is used for noncommercial purposes.
 - i. Land application sites permitted by DHEC under Regulation R.61-107.15 (Solid Waste Management: Land Application of Solid Waste).
 - j. Construction sites where an engineered foundation requires the use of clean sand, clean soil, and/or clean rocks. Such sites shall possess a valid county building permit.

(Ord. No. 2007/37, 10-22-2007)

Sec. 62-43. Federal, state and local law.

All solid waste management facilities and composting facilities shall adhere to all federal and state rules and regulations, and all local zoning, land use and other applicable local ordinances.

(Ord. No. 2007/37, 10-22-2007)

Secs. 62-44—62-46. Reserved.**Sec. 62-47. Remedies.**

In case any solid waste management facility or composting facility is operated, constructed, modified, or expanded in violation of this article, the county council, county attorney, or any person aggrieved, may, in addition to other remedies provided by law, institute injunction, abatement, or any other appropriate action or proceeding to prevent, enjoin, abate, or remove such unlawful construction, modification, or expansion.

(Ord. No. 2007/37, 10-22-2007)

ARTICLE IV ~~¶~~. RESIDENTIAL SOLID WASTE COLLECTION CONTRACTS**Sec. 62-48. General conditions for granting contracts or franchises for residential solid waste collection**

The unincorporated areas of the county are divided into solid waste districts which shall be designated as service areas. Contracts or franchises may be awarded for the unincorporated areas of the county incrementally, when approved by county council. These areas shall be plainly outlined on a map of the county as approved by county council. Such maps shall be made a part of the contract with the collectors and shall be available for public inspection.

(Ord. No. 2007/37, 10-22-2007)

Sec. 62-49. Collection contract.

Upon award by the county council, a franchise or contract shall not become effective until the collector has executed a written agreement or contract consistent with the terms of the bid specifications.

(Ord. No. 2007/37, 10-22-2007)

Secs. 62-50, 62-51. Reserved.**ARTICLE ~~IV~~ V . SOLID WASTE AND RECYCLING BOARD²****Sec. 62-52. Purpose.**

In compliance with and under authority of section 62-21 et seq., the county council establishes the solid waste and recycling board (referred to in this article as the board) to advise the council and county staff in determining appropriate levels of public recycling and solid waste management services for residential, commercial and industrial taxpayers and governmental entities within the county; to recommend appropriate funding levels for provision of services in the aforementioned sectors; and to support and promote source

²Cross reference(s)—Boards and commissions, § 2-191 et seq.

reduction, reuse, recycling and composting and means of diverting and managing the solid waste stream within the county.

(Ord. No. 2007/37, 10-22-2007)

Sec. 62-53. Membership.

- (a) The solid waste and recycling board shall consist of one nonvoting representative from the following districts as defined in section 62-29:

Solid Waste District	Municipality
1	City of Beaufort
2	Town of Port Royal
3	Town of Hilton Head Island
4	Town of Bluffton

- (b) The board shall consist of one voting representative from each of the following districts as defined in section 62-29:

Solid Waste District	Area
5	Sheldon Township
6	Unincorporated Port Royal Island
7	Lady's Island
8	Saint Helena Island and Islands East
9	Bluffton Township

- (c) Terms of office shall be staggered. Of the first five members appointed, three shall be appointed for four-year terms, and two shall be appointed for two-year terms. A chairman and vice-chairman shall be elected by the voting members of the board. The chairman and vice-chairman must be voting members of the board.
- (d) The board may consult, from time to time, with representatives of public and private solid waste management organizations.
- (e) While no other eligibility criteria are established, it is requested that members possess experience in one or more of the following areas:
 - (1) Solid waste management.
 - (2) Solid waste facilities planning.
 - (3) Environmental education.
 - (4) Budget and finance issues.
- (f) The board may invite military installations in Beaufort County to appoint a liaison person to serve as a nonvoting member of the board. The board may appoint representatives from other government organizations to serve as nonvoting members of the board.

(Ord. No. 2007/37, 10-22-2007)

Sec. 62-54. Powers and duties.

The powers and duties of the solid waste and recycling board shall be as follows:

- (1) Review and recommend to the county council for approval, a comprehensive county solid waste management plan which is in accordance with the state Solid Waste Management and Policy Act of 1991;
- (2) Develop and submit to the county council for approval service level plans for each of the five unincorporated area solid waste districts;
- (3) Review and approve the annual solid waste and recycling budgets prepared for each of the nine solid waste districts before submission to the county administrator; and present to the county council comments on the budget recommended by the county administrator;
- (4) Seek development of public/private partnership and facilitate intergovernmental contracting for provision of services where appropriate;
- (5) Cooperate with the state DHEC, office of waste reduction and recycling, as well as other public and private agencies having programs directed toward solid waste management programs; and
- (6) Review and make recommendations concerning development of any new public or private solid waste management facilities and services, or changes in existing solid waste management facilities or services to ensure consistency with the comprehensive solid waste management plan of the county.

(Ord. No. 2007/37, 10-22-2007)

~~Sec. 62-55. Severability.~~ Moved to Section 62-8

~~If any section, subsection, or clause of this chapter shall be deemed unconstitutional or otherwise invalid, the validity of the remaining sections, subsections, and clauses shall not be affected thereby.~~

~~(Ord. No. 2007/37, 10-22-2007)~~

~~Sec. 62-56 55. Conflicting ordinances.~~

All ordinances or parts of ordinances in conflict with the provisions of this chapter are hereby repealed.

(Ord. No. 2007/37, 10-22-2007)

~~Sec. 62-5756. Effective dates.~~

This ordinance [Ord. No. ~~2007/3723/~~_____] shall be effective from and after July 1, ~~2008~~-2023.

(Ord. No. 2007/37, 10-22-2007 2023/____Section 62-57 Reserved.

ARTICLE ~~VI~~ VI . LITTER CONTROL AND BEAUTIFICATION BOARD

Sec. 62-58. Title.

The name of the organization shall be known as the Keep Beaufort County Beautiful Board (KBCBB).

(Ord. No. 2018/4, 1-22-2018)

Sec. 62-59 Composition.

The board shall be comprised of the following membership:

- (a) One member from county council district 1.
- (b) One member from county council district 2.
One member from county council district 3.
- (d) One member from county council district 4.
- (e) One member from county council district 5.
- (f) One member from county council district 6.
- (g) One member from county council district 7.
- (h) One member from county council district 8.
- (i) One member from county council district 9.
- (j) One member from county council district 10.
- (l) One member from county council district 11.

(Ord. No. 2018/4, 1-22-2018)

Sec. 62-60. Filling of vacancies; removal of board members; terms.

- (1) A vacancy on the board is filled in the same manner as provided for under sections 2-191 through 2-198 of the Beaufort County Code of Ordinances, upon nomination of the respective member of county council.
- (2) Board members are subject to removal procedures provided in section 2-193 of the Beaufort County Code of Ordinances.
- (3) Board members shall serve at the pleasure of county council. Board members shall be appointed to one term. A term of appointment shall be for four years. No board member shall serve for more than four consecutive terms except that county council may approve a fifth term by unanimous vote.
 - a. Upon passage of this article, all 11 board members shall be appointed by county council.
 - b. For districts 1, 2, 3, 4, 5, and 6 the board members shall be re-appointed after the initial two years for a full four-year term, thereby staggering appointments of board members. The initial two-year term shall not count toward the four-term limit.
 - c. For districts 7, 8, 9, 10, and 11, the board members' term shall expire after the full four-year term and vacancies be filled by re-appointment or filled by new appointment.

(Ord. No. 2018/4, 1-22-2018)

Sec. 62-. Officers, officers' duties, and elections of officers.

The members shall elect three officers from its membership, a chairperson, a co-chairperson and a secretary. A majority of board members present and voting, when a quorum is established, shall elect the officers.

- (1) *Chairperson.* The chairperson shall be responsible for leading the board in program development and policy consistent with the Keep American Beautiful objectives. The chairperson shall be spokesperson for the board

at functions, prepare and work with the county staff in preparation of reports including but not limited to the annual Keep America Beautiful report and perform such other duties as the board shall elect.

- (2) *Co-chairperson*. The co-chairperson shall serve as the chairperson in his or her absence and shall discharge such other duties as the board shall direct.
- (3) *Secretary*. The secretary shall keep minutes of all board meetings and shall forward the approved minutes to the appropriate county staff person for record keeping and storage. The secretary shall also perform such other duties as the board shall direct.

(Ord. No. 2018/4, 1-22-2018)

Sec. 62-62. Meetings.

The board shall meet at the call of the chairperson, at least quarterly, and shall be conducted in compliance with the South Carolina Freedom of Information Act. Minutes shall be kept of any meetings and the minutes shall be stored in the Department of Public Works Office of Solid Waste and Recycling or the Records Management Department of the county. A majority of the number of members on the board shall constitute a quorum for transaction of business at any meeting. A majority of those present and voting shall be required to decide any issue after a quorum has been established.

(Ord. No. 2018/4, 1-22-2018)

Sec. 62-63. Purpose.

The purpose of the board will be to educate and empower the Beaufort County Community (including governments, businesses, schools, and citizens) to participate directly in improving the environment through an all-out effort in beautification, litter control, and waste reduction.

(Ord. No. 2018/4, 1-22-2018)

Sec. 62-. Objectives.

The objectives of the board include, but are not limited to:

- (a) Conduct and promote continuing education programs; and
- (b) Develop new programs which will result in the sustained reduction of litter, graffiti and increase recycling in Beaufort County; and
- (c) Encourage stricter code enforcement regarding litter and dumping; and
- (d) Review and recommend appropriate legislative changes regarding environmental ordinances in Beaufort County; and
- (e) Encourage placing, planting and preservation of trees, flowers, shrubs and objects of ornamentation in Beaufort County; and
- (f) Maintain affiliate certification with Keep America Beautiful; and
- (g) File the required annual report to Keep America Beautiful; and
- (h) Pursue and secure funding from available sources.

(Ord. No. 2018/4, 1-22-2018)

Sec. 62-65. Keep America Beautiful affiliation.

The board shall maintain the Keep America Beautiful affiliation status and utilize the KAB resources whenever possible. The board's activities are limited to the boundaries of Beaufort County but should not be construed to exclude activities within the municipal boundaries located in Beaufort County.

(Ord. No. 2018/4, 1-22-2018)

Sec. 62-66. Annual budget.

The board shall submit a recommended annual budget to Beaufort County Council for review and adoption indicating all anticipated sources of revenue, all anticipated expenditures, and any remaining funds that have been carried over from previous years. Additionally, the board shall advise and make recommendations to county council on the expenditure of any and all county funds that may be appropriate to it as well as the design and implementation of any improvement projects that will occur on land owned, maintained, or subject to the control of Beaufort County Council.

(Ord. No. 2018/4, 1-22-2018)

Sec. 62-. Appointment of other committees.

The board may appoint such other standing, special, or advisory committees from time to time as it deems appropriate. Members of such committees may include board members, as well as individuals representing specialized interests in areas that would be beneficial to the board carrying out its purpose.

(Ord. No. 2018/4, 1-22-2018)

Sec. 62-. Conflict of interest.

The board shall adhere to all conflict of interest prohibitions and disclosure requirements provided in S.C. § 8-13-700 et seq., as well as any applicable provisions of the Beaufort County Code of Ordinances.

(Ord. No. 2018/4, 1-22-2018)

ORDINANCE 2023/ XX

An Ordinance amending Ordinance 2007/27, Chapter 62 Solid Waste

WHEREAS, on October 22, 2007, Beaufort County adopted Chapter 62 of the Beaufort County Code of Ordinance for Solid Waste; and

WHEREAS, in May of 2005, Beaufort County adopted Article II – Trash and Litter control ; and

WHEREAS, staff of both Code Enforcement and Public Works Departments found conflicting language for litter control enforcement between Article II and Chapter 62; and

WHEREAS, staff wish to amend Chapter 62 to reflect language found within Article II, contained here within as exhibit A.

NOW, THEREFORE, BE IT ORDAINED BY BEAUFORT COUNTY COUNCIL THAT Ordinance 2007/37 which appears in Beaufort County Code of Ordinances at Chapter 262, Solid Waste are hereby amended.

Adopted this _____ day of _____ 2023

COUNTY COUNCIL OF BEAUFORT COUNTY

By: _____

Joseph Passiment, Chairman

ATTEST:

Sarah w. Brock, JD, Clerk to Council

RESOLUTION NO. 2023 /

A RESOLUTION TO ACCEPT A GRANT FROM THE SC DEPARTMENT OF AGRICULTURE IN THE AMOUNT OF \$50,000 FOR PROJECT COMIDA.

WHEREAS, The SC Department of Agriculture has awarded a total grant of \$50,000 to the Project Comida, and

WHEREAS, these projects reflect an \$8.1 M investment and 40 new jobs in Beaufort County, and

WHEREAS, the company associated with the project, SERG Restaurant Group, will be sourcing agricultural related products from within South Carolina, and

WHEREAS, the \$50,000 grant is a reimbursement grant from SCDOA to the company for building/infrastructure costs, and

WHEREAS, SC Department of Agriculture grants are structured as ‘flow through’ grants with the County. This requires SC Department of Agriculture to send the funds to the County and the County to provide the grant to the company, and

NOW, THEREFORE, be it resolved that Beaufort County Council, duly assembled, does hereby authorize the County Administrator to accept a grant from the SC Department of Agriculture in the amount of \$50,000 for Project Comida.

Adopted this 25th day of September 2023.

COUNTY COUNCIL OF BEAUFORT COUNTY

BY: _____
Joseph Passiment, Chairman

ATTEST:

Sarah W. Brock, Clerk to Council



BEAUFORT COUNTY COUNCIL AGENDA ITEM SUMMARY

ITEM TITLE:
RECOMMEND APPROVAL OF AN ORDINANCE AUTHORIZING THE INTERIM COUNTY ADMINISTRATOR TO EXECUTE ANY AND ALL DOCUMENTS NECESSARY TO ACCEPT RIGHT OF WAY ON DIANAH'S DRIVE
MEETING NAME AND DATE:
Public Facilities & Safety Committee Meeting September 25,2023
PRESENTER INFORMATION:
Jared Fralix, P.E., Assistant County Administrator, Infrastructure Eric Claussen, Director of Engineering (5 Minutes)
ITEM BACKGROUND:
The County paved Dianah's Drive in 2006 as part of Contract 24. Parcel R510 011 000 0128 0000 had a platted 30' wide section of the road on which the County claimed a prescriptive easement based on recorded plats. The County acquired a 50' ROW from abutting property owners along Dianah's Drive but did not request a formal conveyance of ROW from the owner of parcel R510 011 000 0128 0000. Now the owner of parcel R510 011 000 0128 0000 is working with the Town of Hilton Head on development associated with parcel R510 011 000 0128 0000.
PROJECT / ITEM NARRATIVE:
The property owner of parcel R510 011 000 0128 0000 would like to deed their interest in a 30' ROW for the section of the road that traverses their parcel. They are working with the Town of Hilton Head Island planning department and the Town will approve their design plans if the County accepts the 30' ROW for this section of Dianah's Drive. County Engineers have performed a site visit and have approved the requested 30' ROW which will formalize the County's ROW interest in Dianah's Drive.
FISCAL IMPACT:
None
STAFF RECOMMENDATIONS TO COUNCIL:
Staff recommends acceptance of 30' ROW from owner of parcel R510 011 000 0128 0000
OPTIONS FOR COUNCIL MOTION:
Motion to approve/deny an ordinance authorizing the county administrator to execute any and all documents necessary to accept right of way on Dianah's drive. A Majority Vote for acceptance by Committee would move item to County Council for three readings and a public hearing to approve the ordinance.

Dianah's Drive Location Map

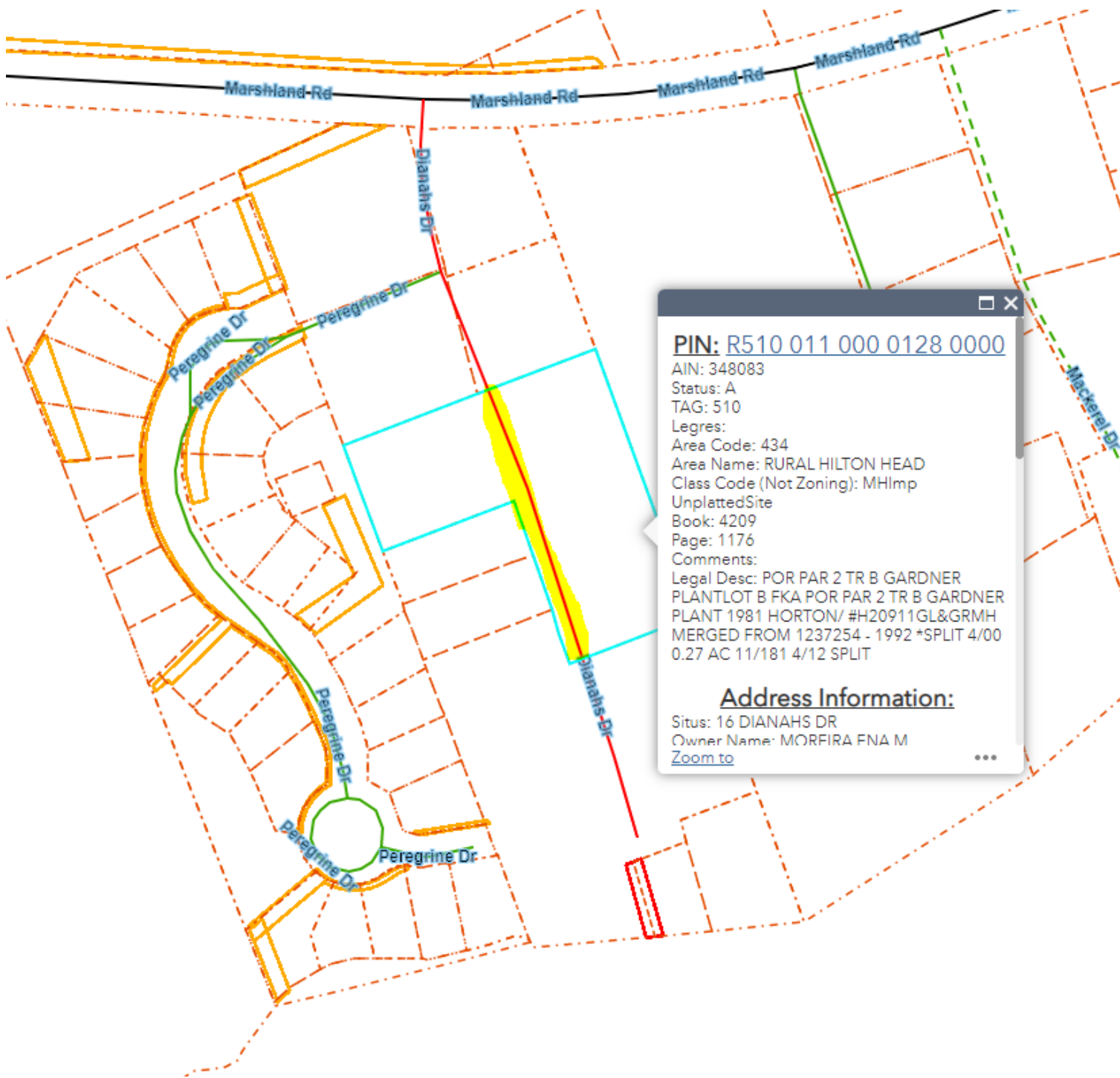



Exhibit "A"

SOME OR ALL AREAS ON THIS PLAT ARE FLOOD HAZARD AREAS AND HAVE BEEN IDENTIFIED AS HAVING AT LEAST A ONE PERCENT CHANCE OF BEING FLOODED IN ANY GIVEN YEAR BY RISING TIDAL WATERS ASSOCIATED WITH POSSIBLE HURRICANES. LOCAL REGULATIONS REQUIRE THAT CERTAIN FLOOD HAZARD PROTECTIVE MEASURES BE INCORPORATED IN THE DESIGN AND CONSTRUCTION OF STRUCTURES IN THESE DESIGNATED AREAS. REFERENCE SHALL BE MADE TO THE DEVELOPMENT COVENANTS AND RESTRICTIONS OF THIS DEVELOPMENT AND REQUIREMENTS OF THE TOWN BUILDING OFFICIAL. IN ADDITION, FEDERAL LAW REQUIRES MANDATORY PURCHASE OF FLOOD INSURANCE AS A PREREQUISITE TO FEDERALLY INSURED MORTGAGE FINANCING IN THESE DESIGNATED FLOOD HAZARD AREAS.

R510 011 000 022C 0000
 ROLLERS TRAILER PARK LLC
 3699 INVERNESS WAY
 MARTINEZ CA 90907



LINE	LENGTH	BEARING
L1	42.05'	N12°21'31"W
L2	29.59'	N19°20'10"W
L3	15.70'	N19°20'10"W
L4	35.02'	N19°20'10"W
L5	18.31'	N20°06'46"W
L6	33.47'	N20°06'46"W
L7	35.53'	N20°06'46"W
L8	51.28'	N20°06'46"W
L9	1.69'	N20°06'46"W
L10	85.13'	N18°48'18"W
L11	86.23'	N18°48'18"W
L12	140.13'	N20°06'46"W
L13	82.34'	N19°20'10"W
L14	39.01'	N12°21'31"W

AREA TABLE	
TOTAL AREA	1.82 AC. 79,120 S.F.
ACQUISITION AREA	0.24 AC. 10,431 S.F.
REMAINDER	1.58 AC. 68,690 S.F.

LEGEND & SYMBOLS:	
3" CMF □	3" CONCRETE MONUMENT FOUND
3/4" IPFF ○	3/4" IRON PIPE FOUND
1/2" IPF ○	1/2" IRON PIN FOUND
1/2" IPS ○	1/2" IRON PIN SET
⊕	ELECTRIC TRANSFORMER
☎	TELEPHONE SERVICE
Ⓜ	TELEVISION SERVICE
⚡	UTILITY POLE
→	GUY
⊕	WATER METER
⊕	ELECTRIC SERVICE
⊕	SANITARY MANHOLE
⊕	STORM MANHOLE
⊕	SFMPR LATERAL
⊕	FIBER OPTIC

REFERENCE PLAT

1) A RECOMBINATION PLAT OF LOTS B & C, DIANAHS DRIVE, HILTON HEAD ISLAND, BEAUFORT COUNTY, SOUTH CAROLINA. DRAWN: 10/06/10. HELD IN DEED BOOK 3087, PAGE 317, DATED 9/28/11. ROD. BEAUFORT COUNTY, SC. BY: MACK W. THOMAS III S.C.R.L.C. # 14531

PROPERTY AREA = 1.82 AC. 79,120 S.F.
 ADDRESS: 16 DIANAHS DRIVE
 DISTRICT: 510, MAP: 11, PARCEL: 128
 THIS PROPERTY LIES IN F.E.M.A. ZONE X & X SHADED
 BASE FLOOD ELEVATION = NO MINIMUM ELEVATION
 COMMUNITY NO. 450250, PANEL: 0453G, DATED: 3/23/2021

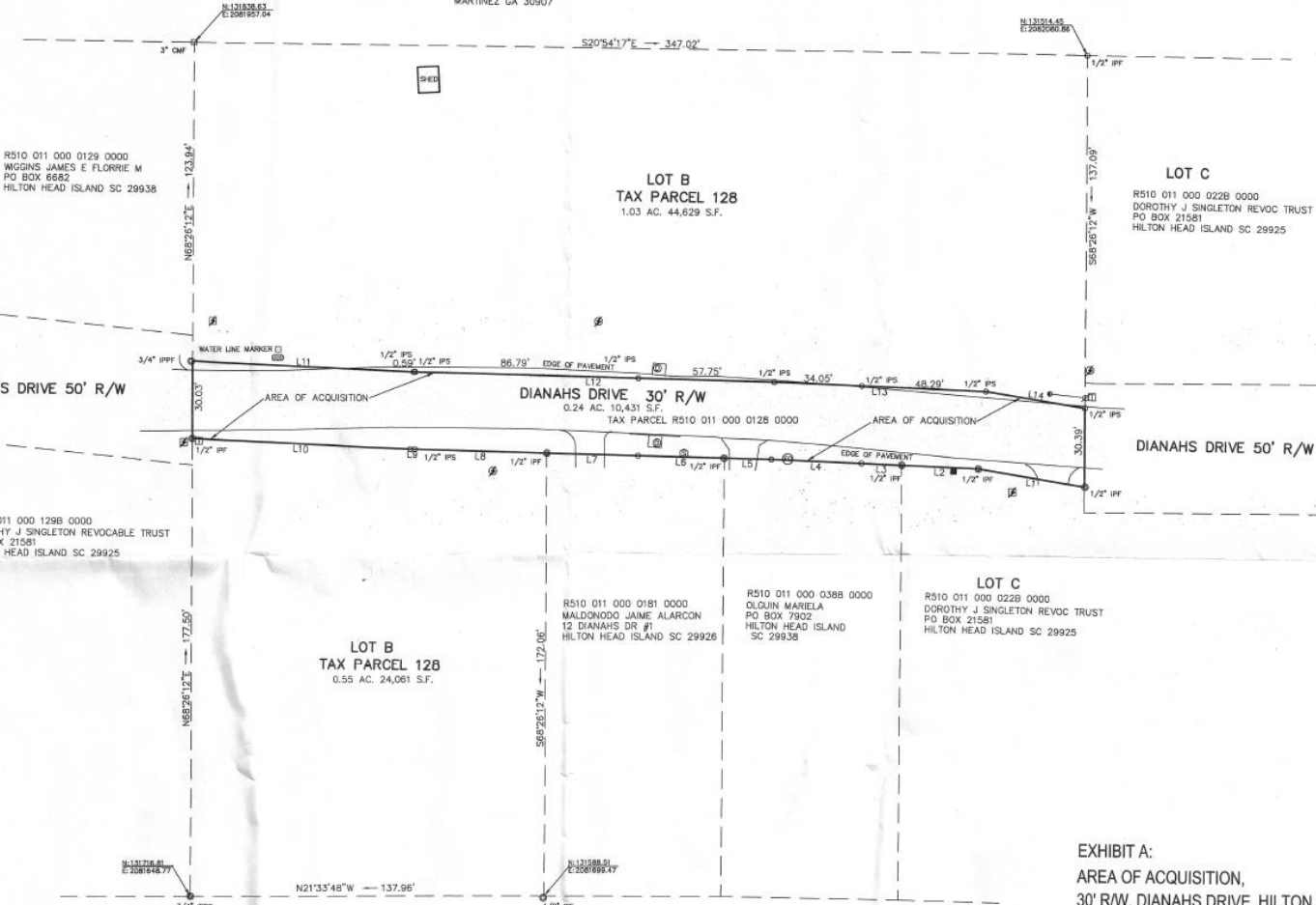

- NOTES:**
- 1) UNDERGROUND UTILITIES NOT LOCATED EXCEPT AS SHOWN.
 - 2) SUBJECT PROPERTY DOES NOT APPEAR TO BE AFFECTED BY THE BEACHFRONT SETBACK REQUIREMENTS OF THE S.C. BEACH PROTECTION ACT OF JULY 1, 1988.
 - 3) HORIZONTAL DATUM IS SOUTH CAROLINA STATE PLAIN NAD 83.
 - 4) BUILDING SETBACKS, WHETHER SHOWN OR NOT, SHOULD BE VERIFIED BY THE LOCAL BUILDING AUTHORITY OR ARCHITECTURAL REVIEW BOARD.
 - 5) THIS SURVEY HAS BEEN PREPARED WITHOUT BENEFIT OF A COMPLETE TITLE SEARCH AND IS SUBJECT TO EASEMENTS AND RESTRICTIONS OF RECORD.
 - 6) THIS SURVEY DOES NOT CERTIFY TO THE EXISTENCE OR ABSENCE OF FRESHWATER WETLANDS.
 - 7) THE ONLY ACTIVITIES PERMITTED IN THE EXTERIOR SUBDIVISION BUFFER AS LABELED ON THIS PLAN SHALL BE THOSE LISTED IN PERMITTED ACTIVITY IN OTHER BUFFER AREA AS PER THE LMO.

I HEREBY STATE THAT TO THE BEST OF MY KNOWLEDGE, INFORMATION, AND BELIEF, THE SURVEY SHOWN HEREON WAS MADE IN ACCORDANCE WITH THE REQUIREMENTS OF THE MINIMUM STANDARDS MANUAL FOR THE PRACTICE OF LAND SURVEYING IN SOUTH CAROLINA, AND MEETS OR EXCEEDS THE REQUIREMENTS FOR A CLASS "A" SURVEY AS SPECIFIED THEREIN. ALSO THERE ARE NO VISIBLE ENCROACHMENTS OR PROJECTIONS OTHER THAN SHOWN.



EXHIBIT A:
 AREA OF ACQUISITION,
 30' R/W, DIANAHS DRIVE, HILTON HEAD ISLAND,
 BEAUFORT COUNTY, SOUTH CAROLINA
 PREPARED FOR: ENA MOREIRA &
 BEAUFORT COUNTY
 DATE: 6/21/2023 SCALE: 1" = 30'



d.b.a. Sea Island Land Survey, Inc.
 10 Oak Park Drive, Unit C1, Hilton Head Island, SC 29926
 Tel (843) 681-3248
 Fax (843) 689-3871
 E-mail: admin@nandinainc.com
 FILE No. : 07322.4 DWG No. : 5-07322.4 RIGHT OF WAY
 COPYRIGHT © BY NANDINA, INC. CAD: BA, PLOD: GJ, MW

ORDINANCE 2023/_____

AN ORDINANCE AUTHORIZING THE INTERIM COUNTY ADMINISTRATOR TO EXECUTE ANY AND ALL DOCUMENTS NECESSARY TO ACCEPT RIGHT OF WAY ON DIANAH'S DRIVE

WHEREAS, Beaufort County (“County”) paved Dianah’s Drive in 2006 as part of Contract 24. The County does not hold title to any part of a parcel designated as Parcel R510 011 000 0128 0000 but it maintains (and in 2006, paved) a 30’ wide section of the parcel pursuant to a claim of a prescriptive easement; and

WHEREAS, the aforementioned property owner is currently working with the Town of Hilton Head Island (“Town”) on design plans . The County is told that the Town will approve the property owner’s proposed design plans if the County accepts conveyance of a 30’ ROW. The property owner now desires to convey their interest in a 30’ wide ROW to Beaufort County as shown on attached Exhibit “A” and the County wishes to accept it; and

WHEREAS, it is in the best interest of the Dianah’s Drive community and the County to accept the property from the property owner to perfect the right of way.

NOW, THEREFORE, BE IT RESOLVED that Beaufort County Council hereby authorizes the Interim County Administrator to execute any and all documents necessary to accept conveyance of a 30’ wide ROW on the above referenced parcel on Dianah’s Drive.

ADOPTED this _____ day of _____, 20____.

COUNTY COUNCIL OF BEAUFORT COUNTY

By: _____
Joseph Passiment, Chairman

ATTEST:

Sarah W. Brock,
Clerk to Council



BEAUFORT COUNTY COUNCIL

AGENDA ITEM SUMMARY

ITEM TITLE:
An ordinance to approve a lease agreement between Beaufort County and Edison Foard, Inc., at 30 Hunter Rd., Hilton Head Island.
MEETING NAME AND DATE:
Public Facilities and Safety Committee; September 25, 2023
PRESENTER INFORMATION:
Jon Rembold; Airports Director 3 minutes
ITEM BACKGROUND:
Edison Foard is the contractor that was selected to perform the Phase I Terminal Improvements Project. Their team and the Airport team have been in communication regarding office space for use during the construction project. The space at 30 Hunter Rd. appears to meet their needs. A DRAFT lease was generated and is included in this package. It was reviewed and approved by Legal Sept 5, 2023 . The legal review is also included in this package. The Airports Board will review the resolution at its monthly meeting scheduled for September 21, 2023.
PROJECT / ITEM NARRATIVE:
Edison Foard, the contractor for Phase I of the Terminal Improvements Project will lease office and warehouse space at 30 Hunter Road, Hilton Head Island, SC 29926. The space will serve as their base of operations during the construction project. The lease was drafted in accordance with the County's lease policy adopted in 2023.
FISCAL IMPACT:
Hilton Head Island Airport will receive income generated through lease revenue --Tenant shall pay \$1,390.00 for office space (814 square feet x \$20.50/12) and \$1,698 for warehouse space (1,406 square feet x \$14.50/12) in monthly base rental payments for premises located at 30 Hunter Rd. These lease rates are in accordance with current Beaufort County lease policies.
STAFF RECOMMENDATIONS TO COMMITTEE:
Staff recommends approval of an ordinance to approve the lease agreement between Beaufort County and Edison Foard, Inc.
OPTIONS FOR COMMITTEE MOTION:
Motion to approve/deny an ordinance to approve a lease agreement between Beaufort County and Edison Foard, Inc. Move forward to Council for Approval on October 9, 2023

STATE OF SOUTH CAROLINA)
)
COUNTY OF BEAUFORT)

**REAL PROPERTY
LEASE AGREEMENT**

THIS REAL PROPERTY LEASE AGREEMENT is made and entered into this _____ day of _____, 2023 (“Lease”), by and between **Beaufort County**, a political subdivision of the State of South Carolina, (“Landlord”) and **Edison Foard, Inc.** (“Tenant”), collectively referred to as the “Parties”.

NOW, THEREFORE, Landlord, for and in consideration of the rents paid and to be paid, and the covenants, conditions, and stipulations to be kept and performed by Tenant, agrees to lease the Premises described herein below.

I. DESCRIPTION OF LEASED PREMISES. The premises to be conveyed is located at **30 Hunter Road, Building 2 Suite C, Hilton Head Island, SC 29926** consisting of 814 sq ft of office space and 1,406 sq ft of warehouse space; hereinafter referred to as “Premises”.

II. TERM

2.1 *Term.* The Lease Term shall be for a term of one year (“Tenancy”) commencing on the date of execution by the County Administrator (“Commencement Date”) and terminating at 11:59 p.m. on **June 30, 2024** (“Termination Date”).

2.2 *Renewal.* This Lease may be renewed upon the mutual consent of the Parties and agreed upon in writing. Any Renewal Term shall include the same terms as this Lease and be for a period up to **three (3)** one-year periods, unless thirty (30) days' prior written notice of intent not to renew is given by either party. The terms set forth in this Paragraph shall collectively be referred to hereafter as a “Renewal Term”.

III. RENTAL PAYMENT

3.1 *Payment of Rent.* Tenant shall pay to Landlord **Three Thousand Eighty Eight Dollars (\$3,088.00)** in monthly rental payments (“Rent”) during the Lease Term, which is apportioned as follows: **Office Rent \$1,390.00 per month and Warehouse Space \$1,698.00.** If occupancy begins and/or ends on any day other than the first day of a month, Rent shall be prorated for the month of commencement and/or month of termination and monthly rent collected in advance thereafter.

The first Rent payment shall be made on or before the Commencement Date. Tenant shall pay all rents due and owing, without deduction or set off, to Landlord at the address set forth in Section 9. All Rent payments shall be made in the form of check or direct deposit.

3.2 *Renewal Rate.* The Rent shall increase by three percent (3%) the first month of any Renewal Term. If the Renewal Term is effective after the 5th of the month, the Rent shall be prorated appropriately.

3.3 *Late Payment of Rent.* Any Rent not paid within five (5) days of the due date shall be deemed late and shall obligate Tenant to pay a late charge of ten percent (10%) of the sum then due.

3.4 *Triple Net Lease.* The Parties agree this is a “triple net lease” and, except as otherwise provided herein, Tenant is responsible for all costs related to the Premises, together with all Improvements constructed thereon, including, without limitation, any taxes or fees, insurance and maintenance.

Landlord Initials _____ Tenant Initials _____

Landlord shall have no responsibility for any such expenses unless specifically provided for herein. The Rent payable under this Lease shall be paid to Landlord without any claim on the part of Tenant for diminution, set-off or abatement and nothing shall suspend, abate or reduce any Rent to be paid hereunder.

3.5 *Security Deposit.* The Landlord requires a Security Deposit equal to one (1) month’s Rent which is equal to **Three Thousand Eighty Eight Dollars (\$3,088.00)**. Landlord has the right to use said Security Deposit for any and all unpaid utilities or any damages to the Premise. If the Security Deposit is used for any reasons stated herein, the Landlord must provide the remaining Security Deposit within ninety (90) days of the date in which Tenant vacates the Premise.

IV. UTILITIES. Tenant shall be responsible for paying one hundred percent (100%) of all utility expenses associated with the Premises during the Initial Term and any Renewal Term. Tenant warrants and agrees to establish accounts in its name with the providing/billing entity or authority and pay for all water, gas, power, electric current, garbage collection and removal, sewer charges, and all other utilities and utility charges and fees charged to the Premises during the term of this Lease and all extensions hereof. Tenant agrees to maintain all utilities at all times during its tenancy, regardless of whether or not Tenant is physically occupying the Premise.

V. CONDITION, USE, MAINTENANCE AND REPAIRS OF PREMISES

5.1 *Acceptance and Condition of the Premises.* The Parties mutually agree that Tenant shall take possession of the Premises on the Commencement Date. Tenant stipulates that he or she has examined the Premises, including the grounds and all buildings and improvements, and that they are, at the time of this Agreement, in good order, repair, and in a safe, clean and tenantable condition. Landlord has made no representation in connection with the Premises and shall not be liable for any latent defects therein; provided, however, that if such latent defects render the Premises uninhabitable for the purposes of this Lease, Tenant may at its option, and upon written notice to Landlord, terminate this Lease.

5.2 *Use of Premises.* Tenant shall use the Premises for the sole purpose of **office and warehouse space rental** (“Permitted Use”). Any change in the use of the Premises may only be undertaken with the written consent of the Landlord. Tenant shall not use the Premises for any illegal purpose, nor violate any statute, regulation, rule or order of any governmental body in its use thereof, nor create or allow to exist any nuisances, nor do any act in or about the Premises or bring anything upon the Premises which will increase the premium for insurance on the Premises.

5.3 *Maintenance.* Tenant, at its sole cost and expense, shall handle or contract for the maintenance of the parking areas, landscaping, grounds and planting care for the Premises, and shall generally maintain the Premises in a neat and orderly condition.

5.4 *Repairs of Premises.* Tenant shall at its own expense keep the Premises in good repair. Tenant shall not perform any additional work upon the Premises without prior written consent of the Landlord. The Premises shall be maintained in a clean and orderly manner. In the event of any damage of the Premises which is the direct result of Tenant, Tenant shall, immediately upon receiving demand from Landlord, correct the damage.

5.5 *Tenant Improvements, Alterations, and Restorations.*

Landlord Initials _____ Tenant Initials _____

5.5.1 *Initial Improvements.* Promptly after Landlord delivers the Premises to Tenant, Tenant shall proceed to prepare the Premises and perform such improvements that are required to utilize the Premises for the Permitted Use, which shall include modifying the interior layout to allow for car rental services office space (the “Tenant’s Initial Improvements”). Prior to performing Tenant’s Initial Improvements and promptly after the Lease is executed, Tenant shall send plans and specifications to Landlord for Landlord’s approval, which approval shall not be unreasonably withheld and Tenant shall not commence any of Tenant’s Initial Improvements until Landlord has approved the plans and specifications.

5.5.2 *Additional Improvements.* Other than Tenant’s Initial Improvements, Tenant shall not make or permit to be made any structural alterations, modifications, additions, decorations or improvements to the Premises, nor shall Tenant make or permit any other work whatsoever that would directly or indirectly involve the penetration or removal (whether permanent or temporary) of, or require access through, in, under, or above any floor, wall or ceiling, or surface or covering thereof in the Premises.

5.5.3 *Cost of Improvements.* Tenant’s Initial Improvements, or any additional improvements as approved by the Landlord, shall be made at Tenant’s sole cost and expense, including the expense of complying with all present and future legal requirements, and any other work required to be performed in other areas within or outside the Premises.

5.5.4 *Compliance.* All such Tenant’s Work shall be performed diligently and in a first class workmanlike manner and in accordance with plans and specifications approved by Landlord, and shall comply with all legal requirements. Any of Tenant’s Initial Improvements or other alterations, including, without limitation, moveable partitions that are affixed to the Premise (but excluding moveable, free standing partitions) and all carpeting, shall at once become part of the Premises and the property of Landlord.

5.6 *Right of Inspection.* Landlord shall have the unfettered right at all reasonable times during the Initial Term or any Renewal Term to enter the Premises for any reason whatsoever. Landlord agrees, when able, to provide Tenant with reasonable notice of said entry upon the Premises. No notice will be required in emergency situations or for access or entry upon the Premises.

VI. DESTRUCTION OR DAMAGE

6.1 If the Premises shall be damaged or destroyed during the term of this Lease by any casualty insured under Landlord's standard fire and casualty insurance, Landlord shall, except as otherwise provided in this Lease and subject to any delay or inability from causes beyond its control, repair and/or rebuild the same substantially to what had been the condition thereof immediately prior to such damage or destruction.

6.2 If the Premises shall be damaged or destroyed to the extent of fifty percent (50%) or more of the insurable value thereof, or if such casualty shall not have been insured against by Landlord's standard fire and casualty policies, then Landlord or Tenant may terminate this Lease or elect to repair such damage or rebuild the Premises. Within thirty (30) calendar days after any such casualty, Landlord shall notify Tenant whether Landlord intends to repair or rebuild the Premises, and Tenant shall notify Landlord whether Tenant intends to terminate this Lease. If Landlord elects to repair or rebuild the Premises, Landlord shall perform such repair or rebuilding as provided in this Agreement. If Landlord elects not to repair or rebuild, the Lease shall terminate without further

Landlord Initials _____ Tenant Initials _____

notice and all further obligations of both parties hereunder shall cease (other than those which shall theretofore have accrued), effective as of the date on which Tenant ceases doing business on the Premises.

- 6.3 If Landlord elects to repair the Premises and Tenant does not elect to terminate the Lease, and if Landlord's repairs are not substantially completed within one hundred twenty (120) calendar days following the date of the casualty, then Tenant, upon not less than thirty (30) calendar days written notice to Landlord, may terminate this Lease if Landlord has not substantially completed such repairs within the time period (which shall not be less than 30 calendar days) set forth in such notice. Substantial completion, as used herein, shall mean that the Premises are restored to the condition that they may be occupied and utilized for their intended purpose, notwithstanding that there may be additional "punch list" or other non-essential items to be completed, which neither affect nor impact Tenant's use and enjoyment of the Premises. Nevertheless, Landlord shall diligently pursue the completion of all remaining work in a timely manner.
- 6.4 During any period of reconstruction or repair of the Premises, provided Tenant has not elected to terminate this Lease, Tenant may at its sole option continue the operation of Tenant's business in the Premises to the extent reasonably practicable from the standpoint of good business practice. Tenant shall not interfere with the repair or restoration activities of Landlord or its contractors, and will adapt and modify its business activities as deemed necessary by Landlord to allow such repair or restoration activities to continue expeditiously.
- 6.5 During any period in which, by reason of any damage or destruction not resulting from the negligence of Tenant, Tenant's employees, agents, or invitees, Tenant is unable to occupy all or a portion of the Premises, Tenant's rent shall be appropriately abated for that part of the Premises rendered unusable for the conduct of Tenant's business. Such abatement shall continue for the period commencing with such destruction or damage and ending with the substantial completion by Landlord of Landlord's repairs and/or rebuilding of the Premises, as described in this Lease.

VII. ASSIGNMENT AND SUBLETTING

The Tenant shall not, without the Landlord's prior written consent: (i) mortgage, pledge, encumber, or otherwise transfer (whether voluntarily, by operation of law, or otherwise) this lease or any interest hereunder; (ii) allow any lien to attach to Tenant's interest in the Premises or this Lease; (iii) permit the use or occupancy of the Premises or any part thereof by anyone for a purpose other than as set forth herein; (iv) assign or convey this Lease or any interest herein; or (v) sublet the Premises or any part thereof; and any attempt to consummate any of the foregoing without Landlord's consent shall be void. Any assignment or subletting of this Lease must be approved in writing by Landlord, which approval shall not be unreasonably withheld. Assignment of the Lease will not relieve the Tenant or the Guarantors of their respective obligations under this Lease and Guaranty Agreement unless otherwise agreed by Landlord in writing.

VIII. TERMINATION. This Lease shall end on the Termination Date. This Lease may be terminated by Landlord prior to the Termination Date upon providing a thirty (30) day notice to Tenant and/or upon the occurrence of any default event as set forth in Section 8.

- 8.1 *Surrender of Property.* At the termination of this Lease, Tenant agrees to quit and deliver the Premises peaceably and quietly to Landlord, or its attorney, or other duly authorized agent, at the expiration or other termination of this Lease. The Tenant shall surrender the Premises in as good

Landlord Initials _____ Tenant Initials _____

state and condition as delivered to Tenant at the commencement of this Lease, reasonable use and wear thereof expected.

- 8.2 *Hold Over.* If, without objection by Landlord, Tenant holds possession of the Premises after expiration of the term of this Lease, Tenant shall become a Tenant from month to month upon the terms herein specified, but at a monthly rent amount equivalent to 150% of the gross rent being paid (starting sixty (60) calendar days after the expiration of the term of this Lease) at the end of the term of this Lease, and all fees, assessments, costs and other items must continue to be paid pursuant to all the provisions set forth herein. Such month to month rent and other amounts shall be payable in advance on or before the fifteenth (15th) calendar day of each month.

IX. DEFAULT

- 9.1 *Default by Tenant.* The occurrence of any of the following shall constitute an event of default:

- (a) The rent of any other sum of money payable under this Lease, whether to Landlord or otherwise, is not paid within ten (10) days of the due date.
- (b) Tenant's interest in the Lease of the Premises shall be subjected to any attachment, levy, or sale pursuant to any order or decree entered against Tenant in any legal proceeding and such order or decree shall not be vacated within thirty (30) days of entry thereof; unless with respect to any attachment, levy or sale, which cannot be vacated within thirty (30) days, Tenant in good faith shall have commenced and thereafter shall continue to diligently pursue the vacation of such order or decree by lawful means.
- (c) Tenant breaches or fails to comply with any term, provision, condition, or covenant of this Lease, other than the payment of rent, or with any of the rules and regulations now or hereafter established from time to time by the Landlord to govern the operation of the building and such breach or failure to comply is not cured within ten (10) days after written notice of such breach or failure to comply is given to Tenant.

- 9.2 *Remedies of Landlord.* Upon the occurrence of an event of default by Tenant other than a failure of Tenant to timely pay a sum that is due and payable, Landlord shall notify Tenant in writing of the event of default, and Tenant shall, within twenty (20) days of receipt of such written notice cure such event of default. Where the Tenant fails to cure such event of default within twenty (20) days of receipt of the above-referenced written notice, Landlord shall have the option to do and perform any one or more of the following in addition to, and not in limitation of, any other remedy or right permitted by law or in equity or by this Lease. In electing to do any one or more of the following courses of conduct, the Landlord must reasonably undertake its best efforts to properly mitigate any damages caused or sustained by Landlord due to the occurrence of an event of default by the Tenant. The options and courses of conduct which may be undertaken by the Landlord in an event of default by the Tenant are as follows:

- (a) Landlord, with or without terminating this Lease, may immediately or at any time thereafter re-enter the Premises and correct or repair any condition which shall constitute a failure on Tenant's part to keep, observe, perform, satisfy, or abide by any term, condition, covenant, agreement or obligation of this Lease or of the rules and regulations adopted by the Landlord or of any notice given Tenant by Landlord pursuant to the terms of this Lease, and Tenant shall fully reimburse and compensate Landlord on demand for all reasonable expenses.

Landlord Initials _____ Tenant Initials _____

(b) Landlord, with or without terminating this Lease may immediately or at any time thereafter demand in writing that Tenant immediately vacate the Premises whereupon Tenant shall immediately vacate the Premises and, immediately remove therefrom all personal property belonging to Tenant, whereupon Landlord shall have the right to immediately re-enter and take possession of the Premises. Any such demand, re-entry and taking of possession of the Premises by Landlord shall not of itself constitute an acceptance by Landlord of a surrender of this Lease or of the Premises by Tenant and shall not of itself constitute a termination of this Lease by Landlord. In the event the Landlord re-enters and takes possession of the Premises as provided above and the Tenant has failed upon request by Landlord to immediately remove from the Premises all property belonging to or placed upon the Premises by the Tenant, the Landlord shall have the right to have such property of the Tenant removed from the Premises and reasonably be placed within a secure storage facility for a period of time not to exceed thirty (30) days, and all costs of handling, moving and storing such property of the Tenant shall be paid by the Tenant. Notwithstanding any of the foregoing, Landlord shall be required to comply with applicable South Carolina law regarding reentry and possession of the Premises.

(c) Landlord may immediately or at any time thereafter terminate this Lease, and this Lease shall be deemed to have been terminated upon receipt by Tenant of written notice of such termination; upon such termination Landlord shall recover from Tenant all damages Landlord may suffer by reason of such termination including, without limitation, all arrearages in rentals, costs, charges, additional rentals, and reimbursements, the cost (including court costs and attorneys' fees) of recovering possession of the Premises, and, in addition thereto, Landlord at its election shall have and recover from Tenant either: (1) an amount equal to the excess, if any, of the total amount of all rents and other charges to be paid by Tenant for the remainder of the term of this Lease over the then reasonable rental value of the Premises for the remainder of the Term of this Lease, or (2) the rents and other charges which Landlord would be entitled to receive from Tenant if the Lease were not terminated. Such election shall be made by Landlord by serving written notice upon Tenant of its choice of the alternatives within thirty (30) days of the notice of termination. Notwithstanding anything hereunder to the contrary, Landlord must use its reasonable best efforts to re-let the Premises and abate Landlord's damages.

9.3 *No Waiver.* No course of dealing between Landlord and Tenant or any failure or delay on the part of Landlord in exercising any rights of Landlord under any provisions of this Lease shall operate as a waiver of any rights of Landlord, nor shall any waiver of a default on one occasion operate as a waiver of any subsequent default or any other default. No express waiver shall affect any condition, covenant, rule or regulation other than the one specified in such waiver and that one only for the time and in the manner specifically stated.

9.4 *No Election of Remedies.* The exercise by Landlord of any right or remedy shall not prevent the subsequent exercise by Landlord of other rights and remedies. All remedies provided for in this Lease are cumulative and may, at the election of Landlord, be exercised alternatively, successively, or in any other manner, and all remedies provided for in this Lease are in addition to any other rights provided for or allowed by law or in equity.

9.5 *Insolvency or Bankruptcy.* The appointment of a receiver to take possession of all or substantially all of the assets of Tenant, or an assignment by Tenant for the benefit of creditors, or any action taken or suffered by Tenant, or any action against Tenant, under any insolvency, bankruptcy, or reorganization, shall at Landlord's option constitute an event of default under this Lease. Upon the

Landlord Initials _____ Tenant Initials _____

happening of any such event of default or at any time thereafter, this Lease shall terminate five (5) days after written notice of termination from Landlord to Tenant. In no event shall this Lease be assigned or assignable by operation of law or by voluntary or involuntary bankruptcy proceedings or otherwise and in no event shall this Lease or any rights or privileges hereunder be an asset of Tenant under any bankruptcy, insolvency, or reorganization proceedings.

9.6 *Abandonment.* Tenant shall not be considered to have abandoned or vacated the Premises as long as Tenant continues to pay rent and fulfill all other obligations of this Lease, regardless of whether Tenant is actually continuously occupying the space or not, unless Tenant gives notice of termination if and as allowed by this Lease. If Landlord's right of entry is exercised following abandonment of the Leased Premises by Tenant, then Landlord may consider any personal property belonging to Tenant and left on the Leased Premises to have been abandoned, in which case Landlord may dispose of all such personal property in any manner Landlord shall deem proper and is hereby relieved of all liability for doing so.

X. SALE OF PREMISES. In the event the Landlord hereunder, or any successor owner of the Premises, shall sell or convey the Premises, all liabilities and obligations on the part of the Landlord, or such successor owner, under this Lease accruing thereafter shall remain for a minimum sixty (60) days or the Tenant may enter into a new Lease with the successor owner.

XI. COMPLIANCE WITH LAWS. Tenant shall comply, at its own expense, with all statutes, regulations, rules, ordinances and orders of any governmental body, department, or agency thereof which apply to or result from Tenant's use of the Premises.

XII. INSURANCE LIABILITY AND INDEMNIFICATION

12.1 *Insurance Liability.* Landlord has obtained Premise Liability Insurance, which does not cover Tenant's possessions or Tenant's negligence. Tenant must obtain a Renter's Insurance Policy, in an amount of no less than \$1,000,000 in commercial general liability, or other appropriate policies to cover damage or loss resulting from Tenant's negligence. Tenant shall name Landlord as an additional party in any and all insurance policies, and shall provide Landlord with a copy of all policies.

12.1.1 Tenant shall provide proof that payment for the insurance policy has been made initially and thereafter and that the policy has been renewed at least fifteen (15) calendar days prior to the anniversary of the initial year of this lease. Landlord may contact Tenant's insurer(s) or insurer(s)' agent(s) directly at any time regarding Tenant's coverage, coverage amounts, or other such relevant and reasonable issues related to this Lease.

12.2 *Indemnity.* Tenant hereby agrees to indemnify and hold harmless Landlord against and from any and all claims for property damage, or for personal injury, arising out of or in any way arising out of Tenant's use of the Leased Premises or from any activity, work, or thing done, permitted or suffered by Tenant in or about the Leased Premises.

12.3 *Liens.* If any mechanic's or other lien is filed against the Premises for work claimed to have been for or materials furnished thereto, such lien shall be discharged by Tenant within Ten (10) days thereafter, at Tenant's expense by full payment thereof by filing a bond required by law. Tenant's failure to do so shall constitute a material default hereunder.

Landlord Initials _____ Tenant Initials _____

XIII. MISCELLANEOUS PROVISIONS

13.1 *Notices.* Any notice, communication, request, approval or consent which may be given or is required to be given under the terms of this Agreement shall be in writing and shall be transmitted (1) via hand delivery or express overnight delivery service to the Seller or the Purchaser, (2) via facsimile with the original to follow via hand delivery or overnight delivery service, or (3) via e-mail, provided that the sending party can show proof of delivery, as the case may be, at the addresses/numbers set forth below:

AS TO LANDLORD:
Beaufort County
Beaufort County Administration
Post Office Box 1228
Beaufort, SC 29901

Copy To:
Airport
Airport Director, Hilton Head Island Airport
120 Beach City Rd
Hilton Head Island, SC 29926

AS TO TENANT:

With a Copy to:

Edison Foard, Inc.
3900 Rose Lake Drive
Charlotte, NC 28217

13.2 *Entire Agreement.* This Lease constitutes as the sole and entire agreement of Landlord and Tenant and no prior or contemporaneous oral or written representations or agreements between the parties affecting the Premises shall have any legal effect.

13.3 *Counterparts.* This Agreement may be executed in counterparts. Each of the counterparts shall be deemed an original instrument, but all of the counterparts shall constitute one and the same instrument.

13.4 *Severability.* If any portion of this Lease shall be held to be invalid or unenforceable for any reason, the remaining provisions shall continue to be valid and enforceable. If a court finds that any provision of this Lease is invalid or unenforceable, then such provision shall be deemed to be written, construed and enforced as so limited.

13.5 *Amendment.* This Agreement cannot be amended orally or by a single party. No amendment or change to this Agreement shall be valid unless in writing and signed by both Parties to this Agreement.

13.6 *Captions.* The captions used in this Lease are for convenience only and do not in any way limit or amplify the terms and provisions hereof.

13.7 *Successors and Assigns.* The provisions of this Lease shall inure to the benefit of and be binding upon Landlord and Tenant, and their respective successors, heirs, legal representatives, and assigns.

Landlord Initials _____ Tenant Initials _____

- 13.8 *Applicable Law.* The laws of the State of South Carolina shall govern the interpretation, validity, performance and enforcement of this Lease; and, of any personal guarantees given in connection with this Lease.
- 13.9 *Authority.* Each individual and entity executing this Agreement hereby represents and warrants that he, she or it has the capacity set forth on the signature pages hereof with full power and authority to bind the party on whose behalf he, she or it is executing this Agreement to the terms hereof.
- 13.10 *Force Majeure.* Except for timely Rent payment, Landlord or Tenant shall not be in default hereunder when performance of any term or condition is prevented by a cause beyond its control.
- 13.11 *Time is of the Essence.* Time is of the essence of this Lease.
- 13.12 *Quiet Enjoyment.* Landlord hereby covenants, warrants and agrees that so long as Tenant is performing all of the covenants and agreements herein stipulated to be performed on the Tenant's part, Tenant shall at all times during the lease term have the peaceable quiet and enjoyment and possession of the Premises without any manner of hindrance from Landlord or any person or persons lawfully claiming the Premises, or any part thereof.

IN WITNESS WHEREOF, and in acknowledgement that the parties hereto have read and understood each and every provision hereof, the Parties have caused this Agreement to be executed on the date first written above.

LANDLORD:

Witness

Beaufort County Administrator

Witness

Date: _____

TENANT:

Witness

By: _____
Its: _____

Witness

Date: _____

Landlord Initials _____ Tenant Initials _____

PLEASE MAKE SURE YOU ARE USING INTERNET EXPLORER AS YOUR BROWSER

If you have already submitted this information via the Purchasing Contract Review Form, please do NOT submit it here via t

Legal Review Process Instructions



OFFICE OF THE COUNTY ATTORNEY

Post Office Drawer 1228 ž Beaufort, SC 29901
102 Industrial Village Road, Building #1
843.255.2055 (O) ž 843.255.9414 (F)

LEGAL REVIEW REQUEST FORM

Form Number: 2023 - 1406L

Originally submitted on: 9/5/2023 11:31:09 AM

Select Type:

Document Title: 30 Hunter Road Bld 2 Suite C: office&warehouse space lease with Edison Foard

Department:

Requester's Name: Marlene Myers

Ph: 843.255.2944

Em: tracy.myers@bcgov.net

Date Needed by: 9/6/2023

Is this item being presented to Council or Committee? Yes No
(If Yes, please provide meeting date)

Description of Document or Any Concerns:

Is the County receiving a reimbursement or any compensation? Yes No

Description of the Reimbursement or Compensation:

If applicable, please provide the total value amount of the contract:

- Amount BELOW \$50,000.00
- Amount \$50,000 to \$99,999
- Amount \$100,000 and above

Has the item been approved by Council Committee? Yes No N/A

Has the item been approved by full Council? Yes No N/A

Attachments:

 Edison Foard 30 Hunter Road Bld 2 Suite C lease.docx
46.2 KB

2023-09-05T11:35:53

 Lease Rate Breakdown 2023.pdf
144.7 KB

2023-09-05T11:36:53

 No file attached

LEGAL DEPARTMENT USE ONLY- INITIAL REVIEW

Attachments:

 No file attached

 No file attached

 No file attached

- Approved
- On Hold
- Disapproved
- Additional Documents Requested

Does this request need to go to Finance?

- Yes, send to Finance
- No, do not send to Finance
- Send to Contract Specialist

Comments:

Approved. Lease rates are correct for south of broad river office and warehouse. BH 9-5-23

1:14:01 PM

Legal Staff

9/5/2023

Date / Time

ORDINANCE 2023/_____

AN ORDINANCE AUTHORIZING THE COUNTY ADMINISTRATOR TO ENTER INTO A LEASE AGREEMENT BETWEEN BEAUFORT COUNTY AND EDISON FOARD, INC

WHEREAS, the Hilton Head Island Airport (“Airport”) is in the process of expanding the terminal in order to provide better service to both residents and tourists (“Terminal Improvements Project”); and

WHEREAS, Edison Foard, Inc. is the contractor that will execute the Terminal Improvements Project; and

WHEREAS, the Airport desires to enter into a lease agreement with Edison Foard, Inc. ("Lessee"), that shall include a reasonable lease rate based on square footage of the leased space; and

WHEREAS, the Lessee will use off-site office and storage space at 30 Hunter Road, Hilton Head Island, SC 29926, as its base of operations during the Terminal Improvements Project, and desires to use certain areas and facilities owned by the County and acquire from County certain rights and privileges in connection with its use of Airport; and

WHEREAS, the County has the right to permit use of the Airport upon the terms and conditions hereinafter set forth and has full power and authority to enter into this Agreement.

WHEREAS, County Council finds that it is in the best interest of the citizens and residents of Beaufort County for the County Administrator to enter into a Lease Agreement with Edison Foard, Inc.

NOW, THEREFORE, BE IT ORDAINED BY BEAUFORT COUNTY COUNCIL, duly assembled, does hereby authorize the County Administrator to enter into a Lease Agreement with Edison Foard, Inc.

Adopted this ____ day of _____, 2023.

COUNTY COUNCIL OF BEAUFORT COUNTY

BY: _____
Joseph Passiment, Chairman

ATTEST:

Sarah W. Brock, Clerk to Council



BEAUFORT COUNTY COUNCIL AGENDA ITEM SUMMARY

ITEM TITLE:
An ordinance to approve a lease agreement between Beaufort County and High Tide Aviation Scenic Tours
MEETING NAME AND DATE:
Public Facilities and Safety Committee; September 25, 2023
PRESENTER INFORMATION:
Jon Rembold; Airports Director 3 minutes
ITEM BACKGROUND:
High Tide Aviation approached Airport staff earlier this summer about expanding their business to Beaufort Executive Airport. They currently operate in coastal NC and coastal GA. They expressed an interest in leasing space for their operation at the airport. A DRAFT lease was generated and is included in this package. It was reviewed and approved by Legal Sept 8, 2023. The Airports Board reviewed and recommended approval of the agreement at its monthly meeting held July 20, 2023.
PROJECT / ITEM NARRATIVE:
High Tide Aviation has been in business since 2013 and would like to be the premier provider for Beaufort Executive Airport's scenic air tour offerings. Their fleet is made up of Cessna 172s and experienced pilots. High Tide Aviation offers packages designed for different preferences and budgets, and they take every precaution to ensure the safety and enjoyment of passengers. This is an opportunity to expand the opportunities for the general public to enjoy the airport's offerings.
FISCAL IMPACT:
Beaufort Executive Airport will receive income generated through fuel sales, the airport's standard 3% operating agreement, and lease revenue --Tenant shall pay \$231.00 (140 square feet x \$19.80/12) in monthly base rental payments for premises located at the Beaufort Executive Airport terminal. These lease rates are in accordance with current Beaufort County lease policies.
STAFF RECOMMENDATIONS TO COMMITTEE:
Staff recommends approval of an ordinance to approve the lease agreement between Beaufort County and High Tide Aviation Scenic Tours.
OPTIONS FOR COMMITTEE MOTION:
Motion to approve/deny an ordinance to approve a lease between Beaufort County and High Tide Aviation Scenic Tours Move forward to Council for Approval on October 9, 2023

STATE OF SOUTH CAROLINA)
)
COUNTY OF BEAUFORT)

**REAL PROPERTY
LEASE AGREEMENT**

THIS REAL PROPERTY LEASE AGREEMENT is made and entered into this ____day of _____ 2023, (“Lease”), by and between **Beaufort County**, a political subdivision of the State of South Carolina, (“Landlord”) and **High Tide Aviation LLC** (“Tenant”), collectively referred to as the “Parties”.

NOW, THEREFORE, Landlord, for and in consideration of the rents paid and to be paid, and the covenants, conditions, and stipulations to be kept and performed by Tenant, agrees to lease the Premises described herein below.

I. DESCRIPTION OF LEASED PREMISES. The premises to be conveyed is located at 39 Airport Circle, Beaufort SC 29907 (Beaufort Executive Airport - Terminal), hereinafter referred to as “Premises”.

Assigned Room number: 102

Total square feet: 140

II. TERM

2.1 *Term.* The Lease Term shall be effective on the date of execution by the County Administrator (“Commencement Date”) and terminating at 11:59 p.m. on **June 30, 2024** (“Termination Date”).

2.2 *Renewal.* This Lease may be renewed upon the mutual consent of the Parties and agreed upon in writing. Any Renewal Term shall include the same terms as this Lease and be for a period up to **three (3)** one-year periods, unless thirty (30) days prior written notice of intent not to renew is given by either party. The terms set forth in this Paragraph shall collectively be referred to hereafter as a “Renewal Term”.

III. RENTAL PAYMENT

3.1 *Payment of Rent.* Tenant shall pay to Landlord Two Hundred Thirty One dollars (**\$231.00**) (**total square feet x \$19.80/12**) in monthly base rental payments (“Rent”) during the Lease Term. If occupancy begins and/or ends on any day other than the first day of a month, Rent shall be prorated for the month of commencement and/or month of termination and monthly rent collected in advance thereafter.

The first Rent payment shall be made on or before the Commencement Date. Tenant shall pay all rents due and owing, without deduction or set off, to Landlord at the address set forth in Section 9. All Rent payments shall be made in the form of check or direct deposit.

3.2 *Renewal Rate.* The Rent shall increase by three percent (3%) the first month of any Renewal Term. If the Renewal Term is effective after the 5th of the month, the Rent shall be prorated appropriately.

3.3 *Late Payment of Rent.* Any Rent not paid within five (5) days of the due date shall be deemed late and shall obligate Tenant to pay a late charge of ten percent (10%) of the sum then due.

Landlord Initials _____ Tenant Initials _____

- 3.4 *Triple Net Lease.* The Parties agree this is a “triple net lease” and, except as otherwise provided herein, Tenant is responsible for all costs related to the Premises, together with all Improvements constructed thereon, including, without limitation, any taxes or fees, insurance and maintenance. Landlord shall have no responsibility for any such expenses unless specifically provided for herein. The Rent payable under this Lease shall be paid to Landlord without any claim on the part of Tenant for diminution, set-off or abatement and nothing shall suspend, abate or reduce any Rent to be paid hereunder.

IV. **CONDITION, USE, MAINTENANCE AND REPAIRS OF PREMISES**

- 4.1 *Acceptance and Condition of the Premises.* The Parties mutually agree that Tenant shall take possession of the Premises on the Commencement Date. Tenant stipulates that he or she has examined the Premises, including the grounds and all buildings and improvements, and that they are, at the time of this Agreement, in good order, repair, and in a safe, clean and tenantable condition. Landlord has made no representation in connection with the Premises and shall not be liable for any latent defects therein; provided, however, that if such latent defects render the Premises uninhabitable for the purposes of this Lease, Tenant may at its option, and upon written notice to Landlord, terminate this Lease.
- 4.2 *Use of Premises.* Tenant shall use the Premises for the sole purpose of operating fixed-wing scenic air tours and flight training (“Permitted Use”). Any change in the use of the Premises may only be undertaken with the written consent of the Landlord. Tenant shall not use the Premises for any illegal purpose, nor violate any statute, regulation, rule or order of any governmental body in its use thereof, nor create or allow to exist any nuisances, nor do any act in or about the Premises or bring anything upon the Premises which will increase the premium for insurance on the Premises.
- 4.3 *Repairs of Premises.* Tenant shall at its own expense keep the Premises in good repair. Tenant shall not perform any additional work upon the Premises without prior written consent of the Landlord. The Premises shall be maintained in a clean and orderly manner. In the event of any damage of the Premises which is the direct result of Tenant, Tenant shall, immediately upon receiving demand from Landlord, correct the damage.
- 4.4 *Tenant Improvements, Alterations, and Restorations.*

4.4.1 *Initial Improvements.* Promptly after Landlord delivers the Premises to Tenant, Tenant shall proceed to prepare the Premises and perform such improvements that are required to utilize the Premises for the Permitted Use, which shall include approved signage and marketing (the “Tenant’s Initial Improvements”). Prior to performing Tenant’s Initial Improvements and promptly after the Lease is executed, Tenant shall send plans and specifications to Landlord for Landlord’s approval, which approval shall not be unreasonably withheld and Tenant shall not commence any of Tenant’s Initial Improvements until Landlord has approved the plans and specifications.

4.4.2 *Additional Improvements.* Other than Tenant’s Initial Improvements, Tenant shall not make or permit to be made any structural alterations, modifications, additions, decorations or improvements to the Premises, nor shall Tenant make or permit any other work whatsoever that would directly or indirectly involve the penetration or removal (whether permanent or temporary) of, or require access through, in, under, or above any floor, wall or ceiling, or surface or covering thereof in the Premises.

Landlord Initials _____ Tenant Initials _____

4.4.3 *Cost of Improvements.* Tenant’s Initial Improvements, or any additional improvements as approved by the Landlord, shall be made at Tenant’s sole cost and expense, including the expense of complying with all present and future legal requirements, and any other work required to be performed in other areas within or outside the Premises.

4.4.4 *Compliance.* All such Tenant’s Work shall be performed diligently and in a first class workmanlike manner and in accordance with plans and specifications approved by Landlord, and shall comply with all legal requirements. Any of Tenant’s Initial Improvements or other alterations, including, without limitation, moveable partitions that are affixed to the Premise (but excluding moveable, free standing partitions) and all carpeting, shall at once become part of the Premises and the property of Landlord.

4.5 *Right of Inspection.* Landlord shall have the unfettered right at all reasonable times during the Initial Term or any Renewal Term to enter the Premises for any reason whatsoever. Landlord agrees, when able, to provide Tenant with reasonable notice of said entry upon the Premises. No notice will be required in emergency situations or for access or entry upon the Premises.

V. DESTRUCTION OR DAMAGE

5.1 If the Premises shall be damaged or destroyed during the term of this Lease by any casualty insured under Landlord's standard fire and casualty insurance, Landlord shall, except as otherwise provided in this Lease and subject to any delay or inability from causes beyond its control, repair and/or rebuild the same substantially to what had been the condition thereof immediately prior to such damage or destruction.

5.2 If the Premises shall be damaged or destroyed to the extent of fifty percent (50%) or more of the insurable value thereof, or if such casualty shall not have been insured against by Landlord's standard fire and casualty policies, then Landlord or Tenant may terminate this Lease or elect to repair such damage or rebuild the Premises. Within thirty (30) calendar days after any such casualty, Landlord shall notify Tenant whether Landlord intends to repair or rebuild the Premises, and Tenant shall notify Landlord whether Tenant intends to terminate this Lease. If Landlord elects to repair or rebuild the Premises, Landlord shall perform such repair or rebuilding as provided in this Agreement. If Landlord elects not to repair or rebuild, the Lease shall terminate without further notice and all further obligations of both parties hereunder shall cease (other than those which shall theretofore have accrued), effective as of the date on which Tenant ceases doing business on the Premises.

5.3 If Landlord elects to repair the Premises and Tenant does not elect to terminate the Lease, and if Landlord's repairs are not substantially completed within one hundred twenty (120) calendar days following the date of the casualty, then Tenant, upon not less than thirty (30) calendar days written notice to Landlord, may terminate this Lease if Landlord has not substantially completed such repairs within the time period (which shall not be less than 30 calendar days) set forth in such notice. Substantial completion, as used herein, shall mean that the Premises are restored to the condition that they may be occupied and utilized for their intended purpose, notwithstanding that there may be additional "punch list" or other non-essential items to be completed, which neither affect nor impact Tenant's use and enjoyment of the Premises. Nevertheless, Landlord shall diligently pursue the completion of all remaining work in a timely manner.

Landlord Initials _____ Tenant Initials _____

5.4 During any period of reconstruction or repair of the Premises, provided Tenant has not elected to terminate this Lease, Tenant may at its sole option continue the operation of Tenant's business in the Premises to the extent reasonably practicable from the standpoint of good business practice. Tenant shall not interfere with the repair or restoration activities of Landlord or its contractors, and will adapt and modify its business activities as deemed necessary by Landlord to allow such repair or restoration activities to continue expeditiously.

5.5 During any period in which, by reason of any damage or destruction not resulting from the negligence of Tenant, Tenants employees, agents, or invitees, Tenant is unable to occupy all or a portion of the Premises, Tenant's rent shall be appropriately abated for that part of the Premises rendered unusable for the conduct of Tenants business. Such abatement shall continue for the period commencing with such destruction or damage and ending with the substantial completion by Landlord of Landlord's repairs and/or rebuilding of the Premises, as described in this Lease.

VI. ASSIGNMENT AND SUBLETTING

The Tenant shall not, without the Landlord's prior written consent: (i) mortgage, pledge, encumber, or otherwise transfer (whether voluntarily, by operation of law, or otherwise) this lease or any interest hereunder; (ii) allow any lien to attach to Tenant's interest in the Premises or this Lease; (iii) permit the use or occupancy of the Premises or any part thereof by anyone for a purpose other than as set forth herein; (iv) assign or convey this Lease or any interest herein; or (v) sublet the Premises or any part thereof; and any attempt to consummate any of the foregoing without Landlord's consent shall be void. Any assignment or subletting of this Lease must be approved in writing by Landlord, which approval shall not be unreasonably withheld. Assignment of the Lease will not relieve the Tenant or the Guarantors of their respective obligations under this Lease and Guaranty Agreement unless otherwise agreed by Landlord in writing.

VII. TERMINATION. This Lease shall end on the Termination Date. This Lease may be terminated by Landlord prior to the Termination Date upon providing a thirty (30) day notice to Tenant and/or upon the occurrence of any default event as set forth in Section 8.

7.1 *Surrender of Property.* At the termination of this Lease, Tenant agrees to quit and deliver the Premises peaceably and quietly to Landlord, or its attorney, or other duly authorized agent, at the expiration or other termination of this Lease. The Tenant shall surrender the Premises in as good state and condition as delivered to Tenant at the commencement of this Lease, reasonable use and wear thereof expected.

7.2 *Hold Over.* If, without objection by Landlord, Tenant holds possession of the Premises after expiration of the term of this Lease, Tenant shall become a Tenant from month to month upon the terms herein specified, but at a monthly rent amount equivalent to 150% of the gross rent being paid (starting sixty (60) calendar days after the expiration of the term of this Lease) at the end of the term of this Lease, and all fees, assessments, costs and other items must continue to be paid pursuant to all the provisions set forth herein. Such month to month rent and other amounts shall be payable in advance on or before the fifteenth (15th) calendar day of each month.

VIII. DEFAULT

8.1 *Default by Tenant.* The occurrence of any of the following shall constitute an event of default:

Landlord Initials _____ Tenant Initials _____

- (a) The rent of any other sum of money payable under this Lease, whether to Landlord or otherwise, is not paid within ten (10) days of the due date.
- (b) Tenant's interest in the Lease of the Premises shall be subjected to any attachment, levy, or sale pursuant to any order or decree entered against Tenant in any legal proceeding and such order or decree shall not be vacated within thirty (30) days of entry thereof; unless with respect to any attachment, levy or sale, which cannot be vacated within thirty (30) days, Tenant in good faith shall have commenced and thereafter shall continue to diligently pursue the vacation of such order or decree by lawful means.
- (c) Tenant breaches or fails to comply with any term, provision, condition, or covenant of this Lease, other than the payment of rent, or with any of the rules and regulations now or hereafter established from time to time by the Landlord to govern the operation of the building and such breach or failure to comply is not cured within ten (10) days after written notice of such breach or failure to comply is given to Tenant.

8.2 *Remedies of Landlord.* Upon the occurrence of an event of default by Tenant other than a failure of Tenant to timely pay a sum that is due and payable, Landlord shall notify Tenant in writing of the event of default, and Tenant shall, within twenty (20) days of receipt of such written notice cure such event of default. Where the Tenant fails to cure such event of default within twenty (20) days of receipt of the above-referenced written notice, Landlord shall have the option to do and perform any one or more of the following in addition to, and not in limitation of, any other remedy or right permitted by law or in equity or by this Lease. In electing to do any one or more of the following courses of conduct, the Landlord must reasonably undertake its best efforts to properly mitigate any damages caused or sustained by Landlord due to the occurrence of an event of default by the Tenant. The options and courses of conduct which may be undertaken by the Landlord in an event of default by the Tenant are as follows:

- (a) Landlord, with or without terminating this Lease, may immediately or at any time thereafter re-enter the Premises and correct or repair any condition which shall constitute a failure on Tenant's part to keep, observe, perform, satisfy, or abide by any term, condition, covenant, agreement or obligation of this Lease or of the rules and regulations adopted by the Landlord or of any notice given Tenant by Landlord pursuant to the terms of this Lease, and Tenant shall fully reimburse and compensate Landlord on demand for all reasonable expenses.
- (b) Landlord, with or without terminating this Lease may immediately or at any time thereafter demand in writing that Tenant immediately vacate the Premises whereupon Tenant shall immediately vacate the Premises and, immediately remove therefrom all personal property belonging to Tenant, whereupon Landlord shall have the right to immediately re-enter and take possession of the Premises. Any such demand, re-entry and taking of possession of the Premises by Landlord shall not of itself constitute an acceptance by Landlord of a surrender of this Lease or of the Premises by Tenant and shall not of itself constitute a termination of this Lease by Landlord. In the event the Landlord re-enters and takes possession of the Premises as provided above and the Tenant has failed upon request by Landlord to immediately remove from the Premises all property belonging to or placed upon the Premises by the Tenant, the Landlord shall have the right to have such property of the Tenant removed from the Premises and reasonably be placed within a secure storage facility for a period of time not to exceed thirty (30) days, and all costs of handling, moving and storing such property of the Tenant shall

Landlord Initials _____ Tenant Initials _____

be paid by the Tenant. Notwithstanding any of the foregoing, Landlord shall be required to comply with applicable South Carolina law regarding reentry and possession of the Premises.

- (c) Landlord may immediately or at any time thereafter terminate this Lease, and this Lease shall be deemed to have been terminated upon receipt by Tenant of written notice of such termination; upon such termination Landlord shall recover from Tenant all damages Landlord may suffer by reason of such termination including, without limitation, all arrearages in rentals, costs, charges, additional rentals, and reimbursements, the cost (including court costs and attorneys' fees) of recovering possession of the Premises, and, in addition thereto, Landlord at its election shall have and recover from Tenant either: (1) an amount equal to the excess, if any, of the total amount of all rents and other charges to be paid by Tenant for the remainder of the term of this Lease over the then reasonable rental value of the Premises for the remainder of the Term of this Lease, or (2) the rents and other charges which Landlord would be entitled to receive from Tenant if the Lease were not terminated. Such election shall be made by Landlord by serving written notice upon Tenant of its choice of the alternatives within thirty (30) days of the notice of termination. Notwithstanding anything hereunder to the contrary, Landlord must use its reasonable best efforts to re-let the Premises and abate Landlord's damages.
- 8.3 *No Waiver.* No course of dealing between Landlord and Tenant or any failure or delay on the part of Landlord in exercising any rights of Landlord under any provisions of this Lease shall operate as a waiver of any rights of Landlord, nor shall any waiver of a default on one occasion operate as a waiver of any subsequent default or any other default. No express waiver shall affect any condition, covenant, rule or regulation other than the one specified in such waiver and that one only for the time and in the manner specifically stated.
- 8.4 *No Election of Remedies.* The exercise by Landlord of any right or remedy shall not prevent the subsequent exercise by Landlord of other rights and remedies. All remedies provided for in this Lease are cumulative and may, at the election of Landlord, be exercised alternatively, successively, or in any other manner, and all remedies provided for in this Lease are in addition to any other rights provided for or allowed by law or in equity.
- 8.5 *Insolvency or Bankruptcy.* The appointment of a receiver to take possession of all or substantially all of the assets of Tenant, or an assignment by Tenant for the benefit of creditors, or any action taken or suffered by Tenant, or any action against Tenant, under any insolvency, bankruptcy, or reorganization, shall at Landlord's option constitute an event of default under this Lease. Upon the happening of any such event of default or at any time thereafter, this Lease shall terminate five (5) days after written notice of termination from Landlord to Tenant. In no event shall this Lease be assigned or assignable by operation of law or by voluntary or involuntary bankruptcy proceedings or otherwise and in no event shall this Lease or any rights or privileges hereunder be an asset of Tenant under any bankruptcy, insolvency, or reorganization proceedings.
- 8.6 *Abandonment.* Tenant shall not be considered to have abandoned or vacated the Premises as long as Tenant continues to pay rent and fulfill all other obligations of this Lease, regardless of whether Tenant is actually continuously occupying the space or not, unless Tenant gives notice of termination if and as allowed by this Lease. If Landlord's right of entry is exercised following abandonment of the Leased Premises by Tenant, then Landlord may consider any personal property belonging to Tenant and left on the Leased Premises to have been abandoned, in which case

Landlord Initials _____ Tenant Initials _____

Landlord may dispose of all such personal property in any manner Landlord shall deem proper and is hereby relieved of all liability for doing so.

IX. SALE OF PREMISES. In the event the Landlord hereunder, or any successor owner of the Premises, shall sell or convey the Premises, all liabilities and obligations on the part of the Landlord, or such successor owner, under this Lease accruing thereafter shall remain for a minimum sixty (60) days or the Tenant may enter into a new Lease with the successor owner.

X. COMPLIANCE WITH LAWS. Tenant shall comply, at its own expense, with all statutes, regulations, rules, ordinances and orders of any governmental body, department, or agency thereof which apply to or result from Tenant’s use of the Premises.

XI. INSURANCE LIABILITY AND INDEMNIFICATION

11.1 *Insurance Liability.* Landlord has obtained Premise Liability Insurance, which does not cover Tenant's possessions or Tenant's negligence. Tenant must obtain a Renter's Insurance Policy, in an amount of no less than \$1,000,000 in commercial general liability, or other appropriate policies to cover damage or loss resulting from Tenant's negligence. Tenant shall name Landlord as an additional party in any and all insurance policies, and shall provide Landlord with a copy of all policies.

11.1.1 Tenant shall provide proof that payment for the insurance policy has been made initially and thereafter and that the policy has been renewed at least fifteen (15) calendar days prior to the anniversary of the initial year of this lease. Landlord may contact Tenant’s insurer(s) or insurer(s)' agent(s) directly at any time regarding Tenant’s coverage, coverage amounts, or other such relevant and reasonable issues related to this Lease.

11.2 *Indemnity.* Tenant hereby agrees to indemnify and hold harmless Landlord against and from any and all claims for property damage, or for personal injury, arising out of or in any way arising out of Tenant's use of the Leased Premises or from any activity, work, or thing done, permitted or suffered by Tenant in or about the Leased Premises.

11.3 *Liens.* If any mechanic’s or other lien is filed against the Premises for work claimed to have been for or materials furnished thereto, such lien shall be discharged by Tenant within Ten (10) days thereafter, at Tenant’s expense by full payment thereof by filing a bond required by law. Tenant’s failure to do so shall constitute a material default hereunder.

XII. MISCELLANEOUS PROVISIONS

12.1 *Notices.* Any notice, communication, request, approval or consent which may be given or is required to be given under the terms of this Agreement shall be in writing and shall be transmitted (1) via hand delivery or express overnight delivery service to the Seller or the Purchaser, (2) via facsimile with the original to follow via hand delivery or overnight delivery service, or (3) via e-mail, provided that the sending party can show proof of delivery, as the case may be, at the addresses/numbers set forth below:

AS TO LANDLORD: Beaufort County
 Attn: Beaufort County Administration
 Post Office Box 1228
 Beaufort, SC 29901

Landlord Initials _____ Tenant Initials _____

Copy To: Beaufort County
Attn: Beaufort County Public Facility Director
Post Office Box 1228
Beaufort, SC 29901

AS TO TENANT: _____

- 12.2 *Entire Agreement.* This Lease constitutes as the sole and entire agreement of Landlord and Tenant and no prior or contemporaneous oral or written representations or agreements between the parties affecting the Premises shall have any legal effect.
- 12.3 *Counterparts.* This Agreement may be executed in counterparts. Each of the counterparts shall be deemed an original instrument, but all of the counterparts shall constitute one and the same instrument.
- 12.4 *Severability.* If any portion of this Lease shall be held to be invalid or unenforceable for any reason, the remaining provisions shall continue to be valid and enforceable. If a court finds that any provision of this Lease is invalid or unenforceable, then such provision shall be deemed to be written, construed and enforced as so limited.
- 12.5 *Amendment.* This Agreement cannot be amended orally or by a single party. No amendment or change to this Agreement shall be valid unless in writing and signed by both Parties to this Agreement.
- 12.6 *Captions.* The captions used in this Lease are for convenience only and do not in any way limit or amplify the terms and provisions hereof.
- 12.7 *Successors and Assigns.* The provisions of this Lease shall inure to the benefit of and be binding upon Landlord and Tenant, and their respective successors, heirs, legal representatives, and assigns.
- 12.8 *Applicable Law.* The laws of the State of South Carolina shall govern the interpretation, validity, performance and enforcement of this Lease; and, of any personal guarantees given in connection with this Lease.
- 12.9 *Authority.* Each individual and entity executing this Agreement hereby represents and warrants that he, she or it has the capacity set forth on the signature pages hereof with full power and authority to bind the party on whose behalf he, she or it is executing this Agreement to the terms hereof.
- 12.10 *Force Majeure.* Except for timely Rent payment, Landlord or Tenant shall not be in default hereunder when performance of any term or condition is prevented by a cause beyond its control.
- 12.11 *Time is of the Essence.* Time is of the essence of this Lease.
- 12.12 *Quiet Enjoyment.* Landlord hereby covenants, warrants and agrees that so long as Tenant is performing all of the covenants and agreements herein stipulated to be performed on the Tenant's

Landlord Initials _____ Tenant Initials _____

part, Tenant shall at all times during the lease term have the peaceable quiet and enjoyment and possession of the Premises without any manner of hindrance from Landlord or any person or persons lawfully claiming the Premises, or any part thereof.

IN WITNESS WHEREOF, and in acknowledgement that the parties hereto have read and understood each and every provision hereof, the Parties have caused this Agreement to be executed on the date first written above.

LANDLORD:

Witness

Beaufort County Administrator

Witness

Date: _____

TENANT:

Witness

By: _____
Its: _____

Date: _____

Landlord Initials _____ Tenant Initials _____

PLEASE MAKE SURE YOU ARE USING INTERNET EXPLORER AS YOUR BROWSER

If you have already submitted this information via the Purchasing Contract Review Form, please do NOT submit it here via t

Legal Review Process Instructions



OFFICE OF THE COUNTY ATTORNEY

Post Office Drawer 1228 ž Beaufort, SC 29901
102 Industrial Village Road, Building #1
843.255.2055 (O) ž 843.255.9414 (F)

LEGAL REVIEW REQUEST FORM

Form Number: 2023 - 1408L

Originally submitted on: 9/7/2023 11:12:48 AM

Select Type:

Document Title: Lease (office space) at Beaufort Executive Airport: High Tide Aviation

Department: Requester's Name: Marlene Myers

Ph: 843.255.2944 Em: tracy.myers@bcgov.net

Date Needed by: 9/7/2023

Is this item being presented to Council or Committee? Yes No Meeting date: 9/11/2023
(If Yes, please provide meeting date)

Description of Document or Any Concerns:

Is the County receiving a reimbursement or any compensation? Yes No

Description of the Reimbursement or Compensation:

Office Space @ \$19.80 per sq ft (140) = \$231.00 per month
North of Broad Rate



If applicable, please provide the total value amount of the contract:

- Amount BELOW \$50,000.00
- Amount \$50,000 to \$99,999
- Amount \$100,000 and above

Has the item been approved by Council Committee? Yes No N/A



Has the item been approved by full Council? Yes No N/A

Attachments:

 High Tide Aviation Office Lease 090723.docx 44.96 KB	 Lease Rate Breakdown 2023.pdf 144.69 KB	 No file attached
2023-09-07T11:21:47	2023-09-07T11:25:56	

LEGAL DEPARTMENT USE ONLY- INITIAL REVIEW

Attachments:

 No file attached	 No file attached	 No file attached
--	--	--

- Approved
- On Hold
- Disapproved
- Additional Documents Requested

Does this request need to go to Finance?

- Yes, send to Finance
- No, do not send to Finance
- Send to Contract Specialist

Comments:

Approved to go to Council for public hearing and decision to approve or deny. BH

Item 18.

9:14:40 AM
Legal Staff

9/8/2023

Date / Time

ORDINANCE 2023/_____

AN ORDINANCE AUTHORIZING THE COUNTY ADMINISTRATOR TO ENTER INTO A LEASE AGREEMENT BETWEEN BEAUFORT COUNTY AND HIGH TIDE AVIATION, LLC

WHEREAS, the Beaufort Executive Airport (“Airport”) desires to enter into a lease agreement with High Tide Aviation, LLC ("Lessee"), that shall include a reasonable ground lease rate based on square footage of the area leased; and

WHEREAS, the Lessee will engage in the business of offering scenic flight tours, and desires to lease certain area owned by the County and acquire from County certain rights and privileges in connection with its use of Airport grounds; and

WHEREAS, the County has the right to permit use of the Airport grounds upon the terms and conditions hereinafter set forth and has full power and authority to enter into this Agreement; and

WHEREAS, County Council finds that it is in the best interest of the citizens and residents of Beaufort County for the County Administrator to enter into a Lease Agreement with High Tide Aviation, LLC.

NOW, THEREFORE, BE IT ORDAINED BY BEAUFORT COUNTY COUNCIL, duly assembled, does hereby authorize the County Administrator to enter into a Lease Agreement with High Tide Aviation, LLC.

Adopted this ____ day of _____, 2023.

COUNTY COUNCIL OF BEAUFORT COUNTY

BY: _____
Joseph Passiment, Chairman

ATTEST:

Sarah W. Brock, Clerk to Council



BEAUFORT COUNTY COUNCIL AGENDA ITEM SUMMARY

ITEM TITLE:
Recommend Approval of a Resolution to Enter into an Intergovernmental Support Agreement (IGSA) with the Department of Defense to support operations at the Marine Corps Recruit Depot Parris Island (MCRD Parris Island), the Marine Corps Air Station (MCAS) and the Naval Hospital by providing general governmental services. <i>(Fiscal Impact: In each task order, the County would quote a fee that covers all time and material costs to perform the identified work)</i>
MEETING NAME AND DATE:
Public Facilities and Safety Committee on September 25, 2023
PRESENTER INFORMATION:
Jared Fralix, ACA Infrastructure (10 minutes)
ITEM BACKGROUND:
The three military installations in the County not only play a big role in national security but also play a big role in our local economy. Entering into IGSA's with the Installations provides a meaningful way for the local jurisdictions to offer support to the installations and their overall mission. Currently MCRD Parris Island is Requesting we enter into an IGSA to provide swift action to control erosion along installation shore-lines.
PROJECT / ITEM NARRATIVE:
In order to achieve the overall mission of the three installations, many non-mission critical services are required to support the operations at each installation. The Department of Defense has established some parameters through the IGSA process for installations to coordinate with local jurisdictions for support. The installation would identify an area of need and define a specific project and scope. If the County currently provides the service, either directly or through contract, the County would provide a fee and schedule to offer the services. The installation would compare the offer rendered to their internal cost estimate and schedule. Should the proposal by the County prove beneficial from the installation's perspective, the County would execute the task order and perform the work pursuant to the IGSA.
FISCAL IMPACT:
In each task order issued pursuant to an IGSA, the County would quote a fee that covers all time and material costs to perform the identified work.
STAFF RECOMMENDATIONS TO COUNCIL:
Staff recommends approval of the Resolution to authorize the Interim County Administrator to enter into IGSA's to support operations at each of the three installations.
OPTIONS FOR COUNCIL MOTION:
Approve/ deny the Resolution to authorize the Administrator to enter into IGSA's with the U.S. Marine Corps and Department of the Navy for providing general governmental services to the three installations. <i>(Next Step: Pending approval to purchase, this item would move forward to County Council for approval on October 9, 2023)</i>

RESOLUTION 2023/

A RESOLUTION TO AUTHORIZE THE COUNTY ADMINISTRATOR TO ENTER INTO INTERGOVERNMENTAL SERVICE AGREEMENT(S) (IGSA) TO SUPPORT OPERATIONS AT THE MARINE CORPS RECRUIT DEPOT PARRIS ISLAND (MCRD PARRIS ISLAND), THE MARINE CORPS AIR STATION (MCAS), AND THE NAVAL HOSPITAL BY PROVIDING GENERAL GOVERNMENTAL SERVICES

WHEREAS, the MCRD Parris Island, MCAS, Beaufort, and Naval Hospital, Beaufort provide essential functions for the Marine Corp and Department of Defense in their overall mission of national security;

WHEREAS, many non-mission critical activities are required by the installation to provide operations and logistics in support of its overall mission;

WHEREAS, many of non-mission critical activities are similar to those that Beaufort County already provides as essential governmental services on a regular basis;

WHEREAS, some of the identified non-mission critical activities which could be part of an IGSA include, but are not limited to, services such as stormwater improvements, custodial services, and grounds maintenance services.

NOW THEREFORE, BE IT RESOLVED, by the County Council of Beaufort County, South Carolina, that:

1. County Council hereby authorizes the County Administrator to enter into Intergovernmental Service Agreements with the Department of Defense, U.S. Marine Corps, and Department of the Navy to support the three local installations by providing general support and services.
2. The County Administrator is authorized to execute any additional task orders that are within the framework of the said IGSA's.
3. County staff is directed to pursue reasonable compensation for all work and materials provided in the performance of work on the installations as agreed upon prior to providing the requested service.

ADOPTED, this 9th day of October 2023.

COUNTY COUNCIL OF BEAUFORT COUNTY

BY: _____
Joseph Passiment, Chairman

ATTEST:

Sarah W. Brock, Clerk to Council

INTERGOVERNMENTAL SERVICE AGREEMENT BETWEEN
MARINE CORPS RECRUIT DEPOT PARRIS ISLAND, SOUTH CAROLINA
AND BEAUFORT COUNTY, SOUTH CAROLINA, FOR SERVICES

M60169-A100-180807

This is an Intergovernmental Service Agreement (IGSA) between Marine Corps Recruit Depot Parris Island, South Carolina, hereafter referred to as "MCRD Parris Island" or "Installation," and Beaufort County, South Carolina, hereafter referred to as "County." MCRD Parris Island is located within Beaufort County, South Carolina. When referred to collectively, MCRD Parris Island and Beaufort County will be known as the Parties. The Parties undertake this Agreement in order to provide services to MCRD Parris Island.

This IGSA is entered into this ____ day of _____, 2023, pursuant to the statute on the "Installation- support services: intergovernmental support agreements," hereafter referred to as the IGSA statute, codified at 10 U.S.C. §2679. The IGSA statute authorizes the Secretary of the Navy to enter into an IGSA on a sole source basis with a state or local government to receive Installation support and services.

1. BACKGROUND:

1.1 In accordance with the authorities referenced in paragraphs 2.1- 2.3, the Parties began discussions to consider County providing erosion control services to MCRD Parris Island in support of base operations. After conducting a cost-benefit analysis, it was concluded that entering into a partnership with County for certain erosion control measures was reasonable and in the best interests of the Parties, as it achieves cost savings for MCRD Parris Island and provides additional revenues to the county government and their work forces.

1.2 County certifies that it already provides such installation support services for its own use as the term "installation support services" only includes services, supplies, resources, and support typically provided by County for its own needs and without regard to whether such services, supplies, resources, and support are provided to its residents generally, except that the term does not include security guard or firefighting services.

1.3 MCRD Parris Island and County certify that any contract for the provision of installation-support services awarded by the Federal Government or the State or local government pursuant to an IGSA was or shall be awarded on a competitive basis.

2. AUTHORITIES: The following authorities are referenced for the execution of this IGSA.

2.1 10 U.S.C. §2679; formerly 10 U.S.C. §2336, "Installation-support Services: Intergovernmental Support Agreements"

2.2 DoD Instruction 4000.19, "Support Agreements," Dec. 16, 2020

2.3 Commanders Handbook, "Marine Corps Installation Partnership Program Utilizing Intergovernmental Service Agreements" dated Sep. 19, 2017

3. **PURPOSE:** To provide a means by which MCRD Parris Island can employ the County to take swift action to control erosion along Installation shorelines by establishing a Partnership IGSA between the Parties delineating the roles and responsibilities of the Parties, identifying the supplies and services to be furnished by County, the prices to be paid by MCRD Parris Island, and the appropriate reimbursement and quality control procedures. This IGSA is intended to be employed upon signing to promptly control erosion along the Parris Island shore of the Broad River near the weapons housing area retention pond and to provide other Rip-Rap services as requested and able to be supported by the Parties.

3.1 **TASK ORDERS.** A Task Order shall be issued for each project MCRD Parris Island requests the County to assist with pursuant to this Agreement which details the specific details for each task to be completed. The County shall prepare a Supply List and Cost estimate and a Fee Schedule, as identified in Appendixes A and B for each Task Order. The County shall only proceed with work on a Task upon the approval of the submitted estimates for the Task.

4. **RESPONSIBILITIES OF THE PARTIES:**

4.1. County shall:

4.1.1. Coordinate with the designated Point of Contact (POC) for all matters regarding the execution of services arising from this IGSA, and in accordance with Appendix (A) and Appendix (B).

4.1.2. Invoice MCRD Parris Island for services rendered in accordance with the requirements in paragraph 7 of this IGSA.

4.1.3. Be responsible for the results of any actions performed by any County employees, staff, or third-party contractors, to include damages caused by said personnel and any costs associated with obtaining access to the installation. Such costs will not impact those costs associated with Appendix (A).

4.1.4. Coordinate and cooperate with MCRD Parris Island in meeting access requirements and respecting access policy.

4.2. MCRD Parris Island shall:

4.2.1. Designate the MCRD Parris Island Public Works Division to:

4.2.1.1. Inspect all services and supplies as listed in Appendix (A).

4.2.1.2. Ensure County employees, staff, and any third-party contractors involved in fulfilling this agreement comply with Installation access policy and requirements at all times, especially if access is required in sensitive restricted areas.

4.2.1.3. Ensure County is reimbursed for supplies and labor rendered in accordance with the requirements in paragraph 7 of this IGSA by coordinating with the financial POCs described in paragraph 7.2.

4.2.1.4. Retain overall responsibility and decision-making authority for environmental compliance with applicable local, state, and federal requirements, including identifying applicable authorities and obtaining required permissions, unless otherwise agreed upon in this document or in separate signed agreement.

4.2.1.5. Designate the Environmental Division Director to serve as the Installation's liaison with County regarding all matters arising from this IGSA.

4.3. Each and both parties shall:

4.3.1. Cooperate and coordinate in a timely and professional manner to schedule a meeting whenever requested by either Party to identify, present, and mutually resolve in good faith any issues or concerns that could potentially impede successful performance of the IGSA.

4.3.2. Ensure compliance with all applicable laws, regulations, policies, orders, and procedures.

5. PERSONNEL: Each party is responsible for payment of all costs of its personnel, including pay and benefits, support, and travel. Each party is responsible for supervision and management of its personnel. MCRD Parris Island shall reimburse the County for the labor costs of its personnel associated with the work performed pursuant to this Agreement as identified in Appendix A as labor for each specific task or project performed by the County pursuant to this Agreement.

6. GENERAL PROVISIONS:

6.1 POINTS OF CONTACT: The following POC will be used by the Parties to communicate in the implementation of this IGSA. Each party may change its POC in writing upon reasonable notice to the other party.

6.1.1. For County:

6.1.1.1. Primary: County Administrator
Phone: (843) 263-0650

6.1.1.2. Alternate: Assistant County
Phone: Administrator –
Infrastructure
(843) 929-2321

6.1.2. For MCRD Parris Island:

6.1.2.1. Primary: Public Works Division
Phone: (843) 228-4702

6.1.2.2. Alternate: Environmental Director
Phone: (843) 228-3423

6.2 CORRESPONDENCE: All correspondence to be sent and notices to be given pursuant to this IGSA will be addressed, if to County to:

6.2.1. Beaufort County: County Administrator
P.O. Box 1228, Beaufort, SC 29901

and if to MCRD Parris Island, to:

6.2.2. Commanding Officer
(Attn: Environmental Division Director)
MCRD Parris Island
P.O. Box 5028
Beaufort, SC 29902

6.3. FINANCIAL SPECIFICS: Appendix (A) provides all other details and information on the reimbursable support identified in paragraph 4 and in accordance with the fee schedule shown in Appendix (B).

6.4. PAYMENT OF BILLS: All MCRD Parris Island billing will be processed through the Wide Area Work Flow (WAWF) - MISC PAY by the Defense Finance and Accounting Service (DFAS). County will provide MCAS Beaufort a copy of the billed invoice no later than 30 days after the work is complete, for the purposes of reconciliation and concurrence. Bills rendered will not be subject to audit in advance of payment.

6.5 TERM OF THE AGREEMENT: The initial term of this Agreement shall cover a period of five (5) years commencing from the date of execution, unless terminated sooner by agreement of the parties. The term of the agreement may be extended for two additional five (5) year periods upon written approval of the County and MCRD Parris Island.

6.6. AUTHORITY TO EXECUTE: By executing this Agreement, the undersigned each affirms and certifies that he or she has authority to bind his or her principal thereto and that all necessary acts have been taken to duly authorize this Agreement under applicable law.

IN WITNESS WEHREOF, the Parties hereto have executed this Agreement as of the day and year first written above.

BEAUFORT COUNTY

MCRD PARRIS ISLAND

John Robinson
Interim County Administrator

C. D. Roberson
Chief of Staff, MCRD Parris Island

Date: _____

Date: _____

APPENDIX A
SUPPLY LIST AND COST

This IGSA is established for the following supplies:

<u>Material</u>	<u>Amount per load</u>	<u>Cost</u>
Labor		
Equipment rental (excavator, toilet, etc.)		
Geotextile fabric		
Erosion preventative	141 SY	\$X
Rip rap 100 lb. avg, dumped	170 LF	\$X
Rip rap 3/8 to 1/4 c.y. slope protection	325 tons	\$X
	241 SY	\$X

Additional taxes/fees:
NOT APPLICABLE

MCRD Parris Island is not required to pay State or local taxes and County shall not include any State or local taxes in its invoice. There are no additional fees associated with the supplies, and the cost per load is the installed price.

APPENDIX B
FEESCHEDULE

MCRD Parris Island will reimburse County for the supplies required to perform this service as authorized in this agreement, on the following schedule. It is estimated that MCRD Parris Island will require 325 tons of rip rap and 241 square yards of rip rap, 141 square yards of geotextile fabric, and 170 linear feet of erosion control materials, totaling \$XXX.00, for the initial year of this agreement. This agreement authorizes MCRD Parris Island to purchase additional supplies, as needed, for years two through five of this agreement, based on the costs per load established in Appendix A, not to exceed \$XXX.00 in total price paid to County per year.

<u>Material</u>	<u>Amount</u>	<u>Cost</u>
Labor		
Equipment rental (excavator, toilet, etc.)	141 SY	\$X
Geotextile fabric	170 LF	\$X
Erosion preventative	325 tons	\$X
Rip rap 100 lb. avg, dumped	241 SY	\$X
Rip rap 3/8 to 1/4 c.y. slope protection		

Estimated Total
\$XXX.00



BEAUFORT COUNTY COUNCIL AGENDA ITEM SUMMARY

ITEM TITLE:
Recommend Approval of a Resolution for an Addendum to a 2020 Memorandum of Understanding (MOU) with the Town of Hilton Head for the St. James Baptist Church relocation project
MEETING NAME AND DATE:
Public Facilities and Safety, September 25, 2023
PRESENTER INFORMATION:
Jared Fralix Assistant County Administrator – Infrastructure (5 minutes)
ITEM BACKGROUND:
The County and Town of Hilton Head Island have been working jointly with St. James Baptist Church to relocate the church and the historic Cherry Hill School to a new location outside of the runway safety area from the Hilton Head Island Airport. On March 9, 2020, a MOU was entered into by both entities to memorialize their respective commitments towards the project. The parties now wish to add an addendum to the MOU.
PROJECT / ITEM NARRATIVE:
Since the original agreement was entered into, there have been many changes in key project personnel for the County, Town, and Church. With the change in personnel and changes in the project since the original agreement, it has been determined that an addendum to the original agreement to re-memorialize the commitments of each of the stakeholders and to add the Church to it are advisable.
FISCAL IMPACT:
As part of the original MOU, both the Town and County deposited \$150,000 each, totaling \$300,000, into an account to share in the costs to prepare all of the preliminary documentation and studies necessary to secure FAA grant funding for the relocation of the Church and School. To date, there are still sufficient funds in the account for the expected expenses, and no additional funding is required by this Addendum.
STAFF RECOMMENDATIONS TO COUNCIL:
Staff recommends to approve the resolution for an addendum to the 2020 Memorandum of Understanding (MOU) with the Town of Hilton Head for the St. James Baptist Church relocation project
OPTIONS FOR COUNCIL MOTION:
Motion to approve/deny the resolution for an addendum to the 2020 Memorandum of Understanding (MOU) with the Town of Hilton Head for the St. James Baptist Church relocation project. <i>(Move forward to County Council for approval on October 9, 2023)</i>

RESOLUTION 2023/ _____

A RESOLUTION TO APPROVE AN ADDENDUM TO THE 2020 MEMORANDUM OF UNDERSTANDING WITH THE TOWN OF HILTON HEAD FOR THE ST. JAMES BAPTIST CHURCH RELOCATION PROJECT

The County Council of Beaufort County (the “*Council*”), the governing body of Beaufort County, South Carolina (the “*County*”), has made the following findings of fact;

WHEREAS, Beaufort County is the owner and operator of the Hilton Head Island Airport; and

WHEREAS, the Town is a South Carolina Municipal Corporation whose boundaries encompass the entirety of the Airport and is ancillary operations; and

WHEREAS, the St. James Baptist Church is a historic African-American congregation that is located adjacent to and in very close proximity to the north end of the Airport runway; and

WHEREAS, the County entered into a Memorandum of Understanding with the Town of Hilton Head Island relating to efforts to relocate the St. James Baptist Church and School. That agreement is dated March 9, 2020 (the “*Original MOA*”). It memorializes the respective commitments of the parties to evaluate the potential relocation of the Church and School. It also reaffirmed the commitment of the two parties to create a fund to cover anticipated preliminary expenses associated with this project and to contribute One Hundred Fifty Thousand Dollars (\$150,000) Dollars each to that fund; and

WHEREAS, the parties have agreed it is advisable to add an addendum to the original MOU adding St James Baptist Church as a party to the MOU and to state/reaffirm the commitments of the parties to the project. as set forth in Exhibit “A”.

NOW THEREFORE, BE IT RESOLVED BY COUNTY COUNCIL OF BEAUFORT COUNTY, in a meeting duly assembled, that the Addendum as set forth in Exhibit “A” is added to the 2020 MOU between the County and the Town of Hilton Head Island.

ADOPTED, this 25th day of September 2023.

COUNTY COUNCIL OF BEAUFORT COUNTY

BY: _____

Joseph Passiment, Chairman

ATTEST:

Sarah W. Brock, Clerk to Council

EXHIBIT "A"

STATE OF SOUTH CAROLINA)
) FIRST ADDENDUM TO A
) MEMORANDUM OF UNDERSTANDING
 COUNTY OF BEAUFORT) BETWEEN BEAUFORT COUNTY AND
) THE TOWN OF HILTON HEAD ISLAND
)

COOPERATIVE AGREEMENT FOR THE SHARING OF EXPENSES ASSOCIATED WITH THE RELOCATION AND MITIGATION OF ST. JAMES BAPTIST CHURCH

This is a First Addendum to a Memorandum of Understanding entered into between Beaufort County and the Town of Hilton Head Island on March 9, 2020 and is made and entered into this ____ day of _____, 2023, by Beaufort County, a body politic and political subdivision of the State of South Carolina (referred to in this Agreement as the "County"), the Town of Hilton Head Island, a South Carolina Municipal Corporation (referred to in this Agreement as the "Town"), and will now also include the St. James Baptist Church, (referred to in this Agreement as the "Church"). When referenced collectively, these entities will be referred to as the "Parties."

DECLARATION OF INTENT

WHEREAS, St. James Baptist Church is currently located under the approach path of the Hilton Head Island Airport at the immediate northern end of the Airport runway and desires to be relocated from this area due to safety concerns; and

WHEREAS, the Parties have agreed to cooperatively seek financial assistance from the Federal Aviation Administration to fund a portion of these relocation and mitigation expenses; and

WHEREAS, in support of these efforts, the County and the Town previously entered into a Memorandum of Understanding that outlined the cost sharing of various

actions that must be undertaken to develop an informational package detailing the relocation proposal for consideration by the Federal Aviation Administration; and

WHEREAS, it is the intent of the Parties that this First Addendum should be treated as clarification of the roles and responsibilities outlined in the March 9, 2020 Memorandum of Understanding, a copy of which is attached hereto as Exhibit "A."

NOW, THEREFORE, for and in consideration of the mutual covenants and promises set forth within this First Addendum, the Parties hereby agree as follows:

Parties Responsibilities. For the purposes of this agreement, it shall be the responsibility of the Parties to:

- A. Reimburse the Church for the expenses incurred in engaging the services of Your Church Partner, LLC, to develop a proposed relocation plan for the church, including, but not necessarily limited to, obtaining an updated appraisal, current building assessment, revised project scope, architectural design development and outline specifications, and any additional documentation that may be necessary to produce an updated opinion of probable cost. These actions must be done in such a manner so as to be consistent with those requirements set forth under the Federal Aviation Administration Advisory Circular AC150/5100-17, Land Acquisition and Relocation Assistance for Airport Improvement Program Assisted Projects, and the Uniform Relocation Assistance and Real Property Acquisition Act ("URA").
- B. Ensure that any services or expenses that are incurred and which are necessary to prepare the revised information package contemplated

herein are sufficiently documented in order to allow the County and the Town to seek reimbursement of such expenses from the Federal Aviation Administration.

- C. Upon completion of the revised relocation plan as outlined in item A, the Parties agree that they will engage in the following actions consistent with the critical path identified by the Parties at a joint meeting held in February of 2023 and stated herein as follows:
- i. Town Council will formulate a policy determination on the question of what consideration, if any, it will seek for the Town-owned property where the Church will be relocated.
 - ii. Review the revised information package prepared by Your Church Partner, LLC (including updated appraisal, updated building assessment, updated scope of project, and any additional documentation that may be necessary to produce an updated opinion of probable cost) and prepare any additional supporting documentation (i.e. Resolutions, Letters of Support, etc.) that may be necessary to fully communicate the Parties' support for this project.
 - iii. Engage the professional services of an engineering firm or other similarly qualified entity to review the revised information package and provide an opinion on its sufficiency and completeness.
 - iv. Submit the revised information package to the Federal Aviation Administration once deemed complete.

v. Following the determination that the project is eligible for Federal Aviation Administration funding, the Parties will meet to scope and execute any additional service contracts, inclusive of Your Church Partners, LLC, that may be necessary to successfully implement the approved relocation/mitigation plan.

D. The Parties agree that funding for those items identified in sections A, B, and C above shall be from those monies which have previously been contributed by both the County and the Town under the Memorandum of Agreement dated March 9, 2020.

IN WITNESS WHEREOF, the parties have affixed their signatures hereto the date first written herein above.

St. James Baptist Church

Date: _____

Herbert Ford, Trustee

Town of Hilton Head Island

Date: _____

Marc Orlando, Town Manager

Beaufort County, South Carolina

Date: _____

John Robinson, Interim County Administrator

STATE OF SOUTH CAROLINA)
) MEMORANDUM OF UNDERSTANDING
BEAUFORT COUNTY)

THIS MEMORANDUM OF UNDERSTANDING (“Understanding”) is made and entered into this 9 day of MARCH, 2020 by and between Beaufort County, South Carolina (“County”), a political subdivision of the State of South Carolina and the Town of Hilton Head Island, South Carolina (“Town”). The County and the Town will collectively be referred to as the “Parties”.

WHEREAS, County is the owner and operator of the Hilton Head Island Airport (“Airport”); and

WHEREAS, the Town is a South Carolina Municipal Corporation whose boundaries encompass the entirety of the Airport and its ancillary operations; and

WHEREAS, the St. James Baptist Church (“Church”) is a historic African American congregation that is located adjacent to and in very close proximity of the north end of the Airport runway; and

WHEREAS, the County and the Town have been working jointly with the Church to discuss the Airport’s impact on the Church, as well as discussing ways in which to possibly mitigate these impacts on the Church and its parishioners; and

WHEREAS, as a result of these continued discussions, the County, the Town, and the Church have all agreed explore to pursue the possible relocation of the Church and the Cherry Hill School (“School”) to land on Hilton Head Island; and

WHEREAS, in order to facilitate the discussions and analysis associated with this potential action, the County and the Town wish to enter into this Memorandum of Understanding to memorialize their respective commitments to evaluate the potential relocation of the Church and School.

NOW, THEREFORE, be it understood and agreed to between the Parties the following:

1. The County, as the owner and operator of the Airport, will ultimately be the party responsible for submitting a grant application to the Federal Aviation Administration (“FAA”) to facilitate the Church and School relocation. In order to submit this grant application, several preliminary studies and investigations need to be conducted, and have in fact already been conducted, in order to clearly develop a relocation plan which will meet the needs of the Church, be agreeable between the County and the Town, and be acceptable for funding by the FAA.

2. The County and the Town agree to work jointly to identify and contract for these preliminary services.

3. The Town and the County agree to share equally the past, present and future costs associated with these preliminary activities and that any such amounts (including those which have been incurred to date) should be credited as a respective contribution towards any local grant matching requirements that may be ultimately imposed by the FAA as a condition of receiving such grant funding.

4. Upon the signing of this Understanding, the Town will pay unto the County a deposit of One Hundred Fifty Thousand and No/100 Dollars (\$150,000.00) as a deposit to be utilized towards its share of the costs in preparing all preliminary documentation and studies necessary to secure FAA grant funding approval for the relocation of the Church and School.

5. The money received by the County from the Town shall be utilized only for the authorized expenses identified above and any funds which are not spent on such purposes will be returned to the Town upon request by the Town.

6. The County and Town desire to work jointly towards securing a commitment of grant funding from the FAA regarding the relocation of the Church and School. This Understanding shall not be construed as a commitment or as an obligation of either party to provide any additional funding in excess of the amounts discussed above. At no time shall this Understanding be interpreted as conferring a benefit upon a third party, including St. James Baptist Church and Cherry Hill School, nor shall it be interpreted as requiring either the County or the Town to facilitate such relocation of the church or school, either with or without FAA grant funding.

7. This Memorandum of Understanding represents the entire understanding of the Parties' respective obligations and expectations of each other. This Understanding is created and shall be interpreted under the laws of the State of South Carolina.

8. Either Party may withdraw from this Understanding at any time by providing thirty (30) day notice to the other Party in writing. A withdrawing party must satisfy the cost share obligations incurred or mutually agreed to up to the date of such notice.

IN WITNESS WHEREOF, and in acknowledgement that the Parties hereto have read and understood each and every provision hereof, the Parties have caused this Understanding to be executed on the date first written above.

BEAUFORT COUNTY



Ashley M. Jacobs, County Administrator

TOWN OF HILTON HEAD ISLAND

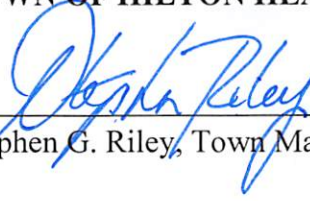

Stephen G. Riley, Town Manager



BEAUFORT COUNTY COUNCIL AGENDA ITEM SUMMARY

ITEM TITLE:
RECOMMEND APPROVAL OF A RESOLUTION AUTHORIZING THE INTERIM ADMINISTRATOR TO ENTER INTO A MOA BETWEEN BEAUFORT COUNTY AND THE CITY OF BEAUFORT TO EXPLORE THE FEASIBILITY OF CO-LOCATING MUNICIPAL FIRE SERVICE AND COUNTY EMS.
MEETING NAME AND DATE:
Public Facilities and Safety Committee September 25, 2023
PRESENTER INFORMATION:
Hank Amundson – Special Assistant to the County Administrator <i>5 Minutes</i>
ITEM BACKGROUND:
Beaufort/Port Royal Fire Department and Beaufort County Emergency Medical Services desire to conduct a feasibility study and conceptual design which may lead to construction documents, which may be used for the remodeling of the building and construction of new living quarters at 135 Ribaut Road, Beaufort SC 29902. If the feasibility study determines co-location at this location is feasible, and the Parties desire to proceed with the remodeling and construction of the Facility at this location, they will enter into a separate agreement establishing the terms and conditions of construction and the financing thereof.
PROJECT / ITEM NARRATIVE:
John Robinson and representatives from the City of Beaufort and Beaufort/Port Royal Fire have devised a potential plan to upgrade the current Beaufort/Port Royal Fire Headquarters to provide space for the collocation of Beaufort County EMS along-side Beaufort/Port Royal Fire staff. Beaufort County EMS is collocated with other fire districts in the County, but to date, not with Beaufort/Port Royal. This request is to authorize the Administrator to enter into an MOA with the City of Beaufort to take the first steps towards potentially making this plan a reality. The plan, if determined to be feasible, would save capital expenditures for the County and the City of Beaufort and enable the more seamless provision of service to the Citizens.
FISCAL IMPACT:
<i>FISCAL IMPACT: Funds in the amount of \$25,000+/- are allocated to the building of a new EMS station in the CIP budget Account #10401230-54420. The fund balance is \$1.5 Million</i>
STAFF RECOMMENDATIONS TO COUNCIL:
Staff recommends approval of a resolution authorizing the Interim County Administrator to enter into the MOA and proceed with this feasibility study.
OPTIONS FOR COUNCIL MOTION:
Motion to approve a Resolution authorizing the Interim County Administrator to enter into an MOA with the City of Beaufort to study the feasibility of co-locating fire and EMS services in the City of Beaufort.

A RESOLUTION TO AUTHORIZE THE INTERIM COUNTY ADMINISTRATOR TO ENTER INTO A MEMORANDUM OF AGREEMENT (MOA) BETWEEN BEAUFORT COUNTY AND THE CITY OF BEAUFORT TO EXPLORE THE FEASIBILITY OF CO-LOCATING MUNICIPAL FIRE SERVICE AND COUNTY EMS.

WHEREAS, Beaufort County Council has allocated funds for the construction of an Emergency Medical Services (EMS) Station, and

WHEREAS, the City of Beaufort, through its Beaufort/Port Royal Fire Department, provides fire and emergency response services to the citizens of the City of Beaufort and Town of Port Royal and needs additional facilities to continue to provide adequate services therein; and

WHEREAS Beaufort County Emergency Medical Services ("County EMS") provides emergency medical patient care for citizens and visitors of Beaufort County, City of Beaufort, and Town of Port Royal and needs additional facilities to continue to provide adequate services in the County; and

WHEREAS, the Parties are dedicated to providing high-quality fire response and emergency care and services to the community, and in furtherance of these goals, desire to enter into this mutually beneficial arrangement to determine the feasibility of co-located service providers; and

WHEREAS, the City of Beaufort currently owns property located at 135 Ribaut Road, Beaufort SC 29902 with current PIN R120 003 000 0078 0000 ("Facility") and operates fire and emergency services to their citizens from this site; and

WHEREAS, the Parties desire to determine the feasibility of co-locating Beaufort/Port Royal Fire Department and Beaufort County Emergency Medical Services on this property and deploying emergency resources out of this facility after completion of an addition and remodeling of the current facility; and

WHEREAS, the Parties desire to conduct a feasibility study and conceptual design in order to determine whether or not to proceed with full design and remodeling of the building to include the addition of new living quarters at 135 Ribaut Road, Beaufort SC 29902.

NOW, THEREFORE, be it resolved that Beaufort County Council, duly assembled, does hereby authorize the Interim County Administrator to enter into an MOA with the City of Beaufort to explore the feasibility of co-locating Municipal Fire Service and County EMS at 135 Ribaut Road, Beaufort, SC 29902.

Adopted this 9th day of October 2023.

COUNTY COUNCIL OF BEAUFORT COUNTY

BY: _____
Joseph Passiment, Chairman

ATTEST:

Sarah W. Brock, Clerk to Council

STATE OF SOUTH CAROLINA)	MEMORANDUM OF AGREEMENT
)	JOINT FIRE AND EMS FACILITY
COUNTY OF BEAUFORT)	CITY OF BEAUFORT

THIS MEMORANDUM OF AGREEMENT (“Agreement”) is made and entered into this ____ day of _____, 2023 (the “Effective Date”) by and between the City of Beaufort, South Carolina, a municipal corporation organized and existing under the laws of the State of South Carolina, (“City”) and Beaufort County, South Carolina (“County”), a political subdivision of the State of South Carolina. The City and the County hereinafter will collectively be referred to as the “Parties.”

WHEREAS, the City, through its Beaufort/Port Royal Fire Department, provides fire and emergency response services to the citizens of the City of Beaufort and Town of Port Royal and is in need of additional facilities to continue to provide adequate services therein; and

WHEREAS, Beaufort County Emergency Medical Services (“County EMS”) provides emergency medical patient care for citizens and visitors of Beaufort County, City of Beaufort, and Town of Port Royal and is in need of additional facilities to continue to provide adequate services in the County; and

WHEREAS, the Parties are dedicated to providing high-quality care and services to the community, and in furtherance of these goals, desire to enter into this mutually beneficial arrangement; and

WHEREAS, the City currently owns property located at 135 Ribaut Road, Beaufort SC 29902 with current PIN R120 003 000 0078 0000 (“Facility”) and operates fire and emergency services to their citizens from this site; and

WHEREAS, the Parties desire to co-locate Beaufort/Port Royal Fire Department and Beaufort County Emergency Medical Services on this property and deploy emergency resources out of this facility after completion of an addition to and remodeling of the current Facility; and

WHEREAS, the Parties desire to conduct a feasibility study and conceptual design which will lead to construction documents, which may be used for the remodeling of the building and construction of new living quarters at 135 Ribaut Road, Beaufort SC 29902; and

WHEREAS, after the completion of the feasibility study and conceptual design, if the Parties desire to proceed with the remodeling and construction of the Facility at this location they will enter into a separate agreement establishing the terms and conditions of construction and the financing thereof (“Construction Agreement”); and

WHEREAS, the Parties shall enter into a separate agreement establishing the terms and conditions of occupying the Facility upon completion of construction (the “Occupancy Agreement”); and

WHEREAS, the Parties recognize that if it is decided to proceed with the remodeling and construction then it is reasonable, necessary, and in the best interest of the public to cooperate and coordinate in the financing and construction of the Facility as described herein.

NOW, THEREFORE, in the public interest, and in consideration of the mutual promises, covenants, terms, and conditions set forth herein, the Parties mutually agree as follows:

I. SCOPE OF WORK.

The County shall contract with a firm to conduct a feasibility study, provide conceptual design, and provide an estimate of cost of construction documents and construction. The addition to the existing structure of living quarters as described in this Section, which shall hereinafter be referred to as the "Project."

II. EFFECTIVE DATE AND TERM.

This Agreement shall be effective as of the "Effective Date" and shall remain in effect for three-years, or upon the completion of the Scope of Work, whichever comes first.

III. CONTRIBUTIONS.

- a. Contributions by the County. The County agrees to provide the funding for the feasibility study, the conceptual design, and the construction cost estimate for property located at the property at 135 Ribaut Road, Beaufort SC 29902, hereinafter referred to as the "Facility".
- b. Contributions by the City. The City agrees to grant access to the Facility for the business of conducting the Project during the term of this Agreement and, if the Project goes forward, the Construction Agreement will provide for County access to the Facility for construction and integration of the additional living quarters with existing infrastructure. The City also contemplates that the Occupancy Agreement will provide for County EMS personnel and equipment to use and occupy the facility following completion of the Project. The terms and provisions of the Construction Agreement and Occupancy Agreement are subject to the terms and conditions agreed to by the Parties and set forth in such agreements.

IV. PROCEDURE.

- a. Design and Permits. The County will use its procurement process as necessary to contract for the feasibility study and conceptual design which will lead to construction documents. The City will cooperate with the County to obtain any and all permits necessary to complete the Project. The Beaufort County Public Safety Director, Beaufort County Director of Emergency Medical Services, and the Beaufort City Fire Chief, or their designees, will collaborate to develop the scope of work for the county procurement process as needed. These personnel will collaborate with County Capital Projects Department and third-party consultants on the design and will be responsible for the final proposed design. The final design shall be approved in writing by the Parties ("Final Design").
- b. Changes to Design. The Parties contemplate that, after the Final Design is approved, if either party requests a change to the Final Design, the requesting party shall be responsible for one hundred percent (100%) of any additional costs associated with drafting the change to the approved design. If the Parties mutually agree to change the Final Design because it is mutually beneficial and the Parties agree in writing to the change, the Parties shall each pay fifty percent (50%) of the costs associated with making the change to the approved Final Design.

V. MISCELLANEOUS

- a. **MUTUAL COOPERATION AND NOTICE.**

Notwithstanding anything contained herein, the County and the City each agree to cooperatively pursue their obligations set forth herein in good faith. Except as explicitly stated previously in this Agreement, all notices to be provided hereunder shall be provided in writing and delivered by U.S. Mail or by email to the following:

If to County, To: Beaufort County Administrator
P.O. Drawer 1228
Beaufort, SC 29901
Phone: 843-255-2027

With Copy to: Beaufort County Director of Public Safety
P.O. Drawer 1228
Beaufort, SC 29901
Phone: 843-255-5171

Beaufort County Director of EMS
2727 Depot Rd,
Beaufort, SC 29902
Phone: 843-255-5368

If to City, To: City Manager
City of Beaufort
1911 Boundary Street
Beaufort, SC 29902
Phone: 843-525-7070

With Copy to: Fire Chief
135 Ribaut Road
Beaufort, SC 29902
Phone: 843-525-7030

b. DEFAULT.

In the event of a default by either party, the non-defaulting party must allow the defaulting party a period of thirty (30) days in which to cure the alleged default. If, after the receipt of such Notice, the defaulting party has not cured the default, the other party may elect to immediately terminate this Agreement. The non-defaulting party may seek any available remedy in equity or at law as a result of such failure to perform, including but not limited to any action for specific performance of obligations recited in this Agreement.

c. TERMINATION.

Either party may terminate this Agreement by notifying the other party in writing with forty-five (45) days Notice.

d. DISPUTE RESOLUTION.

All claims, disputes, and controversies arising out of or in relation to the performance, interpretation, application, or enforcement of this Agreement, including but not limited to breach thereof, shall be first submitted to an agreed upon mediator.

e. **LIABILITY.**

Each Party shall be responsible for its own acts, omissions and negligence and shall not be responsible for the acts, omission, and negligence of the other Party. Neither Party shall be liable to the other Party for any claims, demands, expenses, liabilities, or losses (including attorney's fees) which may arise out of any acts or failures to act by the other party, its employees, or agents, in connection with the performance of services or responsibilities pursuant to this Agreement.

f. **ENTIRE AGREEMENT.**

This Agreement contains the entire agreement between the parties pertaining to the subject matter contained herein and fully supersedes all prior written or oral agreements and understanding between the parties pertaining to such subject matter. References herein to the terms and conditions of the Construction Agreement and the Occupancy Agreement that memorialize certain shared plans and expectations of the Parties will be memorialized, if at all, in definitive documents to be approved by each Party in connection with the Project, and are not binding and do not create any reliance interest on the part of any Party as to the future terms of such Construction Agreement and Occupancy Agreement.

g. **CONFLICTING TERMS.**

In the event that there is any conflict or inconsistency between the terms and conditions of this Agreement and those of any and all prior agreements associated with the Project, the terms and conditions of this Agreement shall control and govern the rights and obligations of the Parties.

h. **APPLICABLE LAW.**

This Agreement is enforceable in the State of South Carolina and shall in all respects be governed by, and constructed in accordance with, the substantive federal laws of the United States and the laws of the State of South Carolina. Any claims filed in connection with this Agreement shall be filed in Beaufort County, South Carolina.

IN WITNESS WHEREOF, and in acknowledgement that the Parties hereto have read and understood each and every provision hereof, the Parties have caused this Agreement to be executed on the Effective Date.

WITNESSES:

BEAUFORT COUNTY

By: _____
John Robinson
Interim County Administrator

WITNESSES:



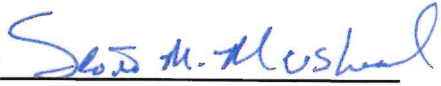

City of Beaufort

By: 

Scott M. Marshall
City Manager

MOA Joint Fire and EMS Facility



BEAUFORT COUNTY COUNCIL AGENDA ITEM SUMMARY

ITEM TITLE:
Recommend Approval of Contract Award to First Construction Management for IFB #082423E Spanish Moss Trail Port Royal Extension (\$1,172,703.89)
MEETING NAME AND DATE:
Public Facilities and Safety Committee – September 25, 2023
PRESENTER INFORMATION:
Eric Claussen, Director of Engineering (5 mins)
ITEM BACKGROUND:
<p>On July 25, 2023, Beaufort County published IFB #082423E Spanish Moss Trail Port Royal Extension requesting competitive bids for the construction of all aspects and scope of the Spanish Moss Trail Port Royal Extension Project. On August 24, 2023, the County received 3 bids. JS Construction’s bid was the lowest bid, but it was deemed non-responsive and rejected for the following reasons:</p> <ul style="list-style-type: none">• The firm is not on SCDOT’s prequalified Prime Contractors list to perform work within state-owned right-of-way.• The firm submitted a bid with a self-performance affidavit despite subcontractors as documented in the email received on August 31, 2023.• The firm’s previous performance on Beaufort County’s projects. <p>First Construction Management was the first qualified competitive bid received.</p>
PROJECT / ITEM NARRATIVE:
The project will consist of construction services for the extension of the Spanish Moss Trail from its current southern terminus, crossing Ribaut Road into Port Royal. The project will include all necessary trail construction, along with a Pedestrian Hybrid Beacon crossing of Ribaut Road. The contract fee is for materials and construction in the amount of \$977,253.24. Staff recommends a 20% contingency of \$195,450.648, bringing the project’s total cost to \$1,172,703.89.
FISCAL IMPACT:
The funding for this project will be Rail Trail account # 48060011-54435 with a balance of \$\$670,437.00 and TAG account # 2342001T-54500 with a balance of \$5,643,326.00.
STAFF RECOMMENDATIONS TO COUNCIL:
Staff recommends approval of contract award to award First Construction Management for IFB #082423E Spanish Moss Trail Port Royal Extension.
OPTIONS FOR COUNCIL MOTION:
<p>Motion to approve/deny the recommendation to award First Construction Management for IFB #082423E Spanish Moss Trail Port Royal Extension.</p> <p><i>Next Step: Move forward to County Council to award First Construction Management for IFB #082423E Spanish Moss Trail Port Royal Extension</i></p>

PRELIMINARY BID TABULATION
PURCHASING DEPARTMENT



Project Name:	Spanish Moss Trail Port Royal Extension
Project Number:	IFB 082423
Project Budget:	
Bid Opening Date:	August 24 2023
Time:	3:00:00 PM
Location:	Beaufort County
Bid Administrator:	Dave Thomas
Bid Recorder:	Victoria Moyer

The following bids were received for the above referenced project:

BIDDER	BID FORM	ALL ADDENDA	Bid Bond	SCH OF VALUES	SMBE Docs	Sub Listing	Grand Total Price
First Construction Management	X	x	x	x	x	x	\$ 977,253.24
JS Construction	X	X	X	X	X	X	\$ 676,278.46
AOS Specialty Contractors	X	X	X	X	X	X	\$ 989,079.30

Beaufort County posts PRELIMINARY bid tabulation information within 2 business days of the advertised bid opening. Information on the PRELIMINARY bid tabulation is posted as it was read during the bid opening. Beaufort County makes no guarantees as to the accuracy of any information on the PRELIMINARY tabulation. The bid results indicated here do not necessarily represent the final compliance review by Beaufort County and are subject to change. After the review, the final award will be made by Beaufort County Council and a certified bid tab will be posted online.

David L. Thomas
Bid Administrator Signature

Victoria Moyer
Bid Recorder



**COUNTY COUNCIL OF BEAUFORT COUNTY
PROCUREMENT SERVICES DEPARTMENT**

102 Industrial Village Road, Bldg 2—Post Office Drawer 1228
Beaufort, South Carolina 29901-1228

September 8, 2023

John Lopat, President
JS Construction Services, Inc.
P.O. Box 1497
Bluffton, SC 29910

David L. Thomas
Procurement Services
Director
843.255.2305
dthomas@bcgov.net

Victoria Moyer
Contract Specialist
843-255-2295
victoria.moyer@bcgov.net

Jessica Snowden
Sr. Administrative Specialist
843-255-2350
jessica.snowden@bcgov.net

Mr. Lopat,

Beaufort County regrets to inform you that JS Construction Services, Inc.'s bid submittal for IFB#082424E Spanish Moss Trail Port Royal Extension has been rejected due to the following:

1. The firm is not on SCDOT's prequalified Prime Contractors list to perform work within state owned right-of-way.
2. The firm submitted a bid with a self-performance affidavit despite subcontractors as documented in the email received August 31, 2023.
3. The firm's previous performance on Beaufort County's projects.

The County reserves the right to reject any bids if it is in the best interest of the County as stated in the solicitation on page 6.

If there are any questions or concerns regarding this matter, please feel free to contact me at 843-255-2304 or dthomas@bcgov.net.

Sincerely,

David L. Thomas

Dave L. Thomas, CPPO, CPPB

Enclosed: 1. SCDOT Prequalified Prime Contractors List dated 09/06/2023
2. JS Construction Services Inc., self-performance affidavit and email dated August 31, 2023.
3. IFB 082423E

SCDOT PREQUALIFIED PRIME CONTRACTOR LIST AS OF 9/6/2023									
VENDOR NAME	DBE/DWBE	MAILING ADDRESS	CITY	STATE	ZIP	APHONE	AEMAIL	Fax	Work Experience
A & A SAFETY, INC.		1126 FERRIS ROAD	AMELIA	OH	45102	(513)943-6100	BILL@AASAFETYINC.COM	(513)943-6106	PAVEMENT MARKINGS • RAISED PAVEMENT MARKERS • TRAFFIC SIGNS - PERMANENT • CONCRETE BARRIERS - CIP • IMPACT ATTEN/CRAH CUSHIONS • TRAFFIC CONTROL SERVICES • ASPH PAVING & RESURFACING • BASE & SUBBASE WORK • CATCH BASIN, MANHOLES, ETC. • CLEARING AND GRUBBING • CONCRETE SDWLKS & DRIVEWAYS • CURB OR CURB & GUTTER • RDWAY EXCAVATION & GRADING • CONC ROADWAY PATCHING • PAVEMENT MARKINGS • CONCRETE PATCH - STRUCTU
A. B. F. ENTERPRISES, LLC		124 PEAK STREET	CHAPIN	SC	29036	(803)995-1191	AFRANK@ABFENTERPRISES.COM		
A. O. HARDEE & SON, INC.		PO BOX 189	LITTLE RIVER	SC	29566	(843)249-1264	DONNIER@AOHARDEE.COM	(843)249-1503	ROAD CONSTRUCTION - NEW • ROADWAY WIDENING • BASE & SUBBASE WORK • CLEARING AND GRUBBING • RDWAY EXCAVATION & GRADING • EROSION CONTROL • SITE PREP • CLEARING AND GRUBBING • BRDG REHAB AND/OR WIDENING • BRIDGE - EMERGENCY REPAIR • BRDG CLEANING AND PAINTING • BRIDGE JACKING • BRIDGE JOINT INSTALL. OR REPAIR • CONCRETE PATCH - STRUCTURES • STRUCTURE REMOVAL • COFFERDAMS & SHEETPIILING • EXPOXY/GROUT CRA
ABHE & SVOBODA, INC.		18100 DAIRY LANE	JORDON	MN	55352	(952)447-6025	DONNELL.HAUCK@ABHEONLINE.COM	(952)447-1000	
ACE CLEARING AND CONSTRUCTION, INC.		PO BOX 128	ROBBINSVILLE	NC	28771	(828)479-9600	ACECLEARING@HOTMAIL.COM	(828)479-9616	CLEARING AND GRUBBING • MOWING/VEG CONTROL • ROAD CONSTRUCTION - NEW • CONCRETE PAVING - ROADWAY • CONCRETE RDWY JOINT SEALS • CURB OR CURB & GUTTER • CONC ROADWAY PATCHING • MILLING & GRINDING • REBAR - PLACING ROADWAY LIGHTING • TRAFFIC SIGNALS•TRAFFIC SIGNS - PERMANENT • CAMERA & ITMS CABLE • OVERHEAD SIGN STRUCTURES •
ACME CONCRETE PAVING, INC.		4124 E. BROADWAY AVENUE	SPOKANE	WA	99202	(509)242-1234	BDAY@ACMECPI.COM	(509)242-1232	
ALS OF NORTH CAROLINA, LLC		502 KLUMAC RD	SALISBURY	NC	28144	(910)483-9100	WSPHOH@ASPLUNDH.COM	(910)483-8137	
AMERICAN CIVIL CONSTRUCTORS WEST COAST, LLC		2990 BAY VISTA COURT, SUITE D	BENICIA	CA	94510	(707)746-8028	ESTIMATINGWC@ACCBUILT.COM	(707)747-0593	ASPH SURF TREAT (CHIP SEAL) • MILLING & GRINDING • BRIDGE REPLACEMENT & APPRS. • BRDG REHAB AND/OR WIDENING • BRIDGE - EMERGENCY REPAIR • BRIDGE JACKING • BRIDGE JOINT INSTALL. OR REPAIR • CONCRETE PATCH - STRUCTURES • NON-AC OVERLAY - BR. DECKS •
AMERICAN CONTRACTING & SERVICES, INC.		6200 E. HWY 62, BLDG 2503	JEFFERSONVILLE	IN	47130	(812)280-4404	RZIMMERMANN@AMERICANCONTRACTING.COM	(812)280-4403	GENERAL • ROAD CONSTRUCTION - NEW • ROADWAY WIDENING • ASPH PAVING & RESURFACING • BASE & SUBBASE WORK • CATCH BASIN, MANHOLES, ETC. • CLEARING AND GRUBBING • CONCRETE SDWLKS & DRIVEWAYS • CURB OR CURB & GUTTER • ASPHALT ROADWAY PATCHING • GUARDRAIL-STL BM/CABLE BA
ANDERS, INC.		220 KAY DRIVE	EASLEY	SC	29640	(864)294-1002	JOLIK@ANDERSINCORPORATED.COM	(864)294-1059	
ANDERZACK-PITZEN CONSTRUCTION, INC.		PO BOX H	METAMORA	OH	43540	(419)644-2111	DAVERYDZINSKI@WECANDIGIT.COM	(419)644-2110	GENERAL • CONCRETE SDWLKS & DRIVEWAYS • ASPHALT ROADWAY PATCHING • HARDSCAPES/STREETSCAPES • PUBLIC UTILITIES INSTALL & REPAIR •
ANSON CONSTRUCTION CO., INC.		PO BOX 31979	CHARLESTON	SC	29417	(843)556-4411	MES@ANSONCONSTRUCTION.COM		ROAD CONSTRUCTION - NEW • ASPH PAVING & RESURFACING • BASE & SUBBASE WORK • CATCH BASIN, MANHOLES, ETC. • CLEARING AND GRUBBING • CONCRETE PAVING - ROADWAY • CONCRETE SDWLKS & DRIVEWAYS • RDWAY EXCAVATION & GRADING • ASPHALT ROADWAY PATCHING • PAVEMENT MA
ANSON CONTRACTORS, INC.		PO BOX 796	WADESBORO	NC	28170	(704)694-6450	DEVIN@ANSONCONTRACTORSINC.COM	(704)694-7401	
ANTHONY ALLEGA CEMENT CONTRACTOR, INC.		5146 ALLEGA WAY	RICHFIELD	OH	44286	(216)447-0814	JWALLIS@ALLEGA.COM	(216)447-5016	GENERAL •
AOS SPECIALTY CONTRACTORS, INC.	DWBE	1224 TWO NOTCH ROAD	LEXINGTON	SC	29073	(803)798-6831	DIANNE@AOSSC.ORG	(888)594-7234	GENERAL •
APAC-ATLANTIC INC.		P.O. BOX 1224	SAVANNAH	GA	31402	(912)443-3400	DEBBIE.RIOS@APACATLANTIC.COM	(912)443-0114	GENERAL •
APPLIED POLYMERIC, INC.		PO BOX 6007	MT. AIRY	NC	27030	(336)789-6159	JSTELE@APPLIEDPOLYMERIC.COM	(336)789-5728	CONCRETE RDWY JOINT SEALS • ASPHALT ROADWAY PATCHING • CONC ROADWAY PATCHING • BRIDGE JOINT INSTALL. OR REPAIR • CONCRETE PATCH - STRUCTURES • ON CALL SERVICES • EXPOXY/GROUT CRACK INJECT • SOIL STABILIZATION•TRAFFIC CONTROL SERVICES •
APTUS GROUP USA, LLC		5930 NORTHWOODS BUSINESS PARKWAY	CHARLOTTE	NC	28269	(704)598-5684	AP@GOAPTUS.COM		*
ARCHER WESTERN CONSTRUCTION, LLC		11000 REGENCY PARKWAY	CARY	NC	27518	(919)463-6772	DPUPKIEWICZ@WALSHGROUP.COM	(919)463-6773	GENERAL •
ARCHER-UNITED JV		11000 REGENCY PARKWAY	CARY	NC	27518	(919)463-6772	ADOUGLAS@WALSHGROUP.COM	(919)463-6773	GENERAL •
ARCHER-UNITED-BLYTHE JV		11000 REGENCY PARKWAY, SUITE 100	CARY	NC	27518	(919)463-6772	ADOUGLAS@WALSHGROUP.COM	(919)463-6773	GENERAL • ROAD CONSTRUCTION - NEW • ASPH PAVING & RESURFACING • BASE & SUBBASE WORK • CLEARING AND GRUBBING • CONCRETE SDWLKS & DRIVEWAYS • CURB OR CURB & GUTTER • SITE PREP •
ARMSTRONG CONTRACTORS, LLC		PO BOX 291053	COLUMBIA	SC	29229	(803)788-1190	MIKE@ARMSTRONGCONTRACTORS.COM	(803)454-0722	
ASPHALT PAVING SYSTEMS, INC.		PO BOX 530	HAMMONTON	NJ	08037	(609)561-4161	APSKEN@ASPHALTPAVINGSYSTEMS.COM	(609)567-2824	GENERAL • ROADWAY WIDENING • ASPH PAVING & RESURFACING • BASE & SUBBASE WORK • CATCH BASIN, MANHOLES, ETC. • CLEARING AND GRUBBING • CONCRETE SDWLKS & DRIVEWAYS • CURB OR CURB & GUTTER • ASPHALT ROADWAY PATCHING • PERM. OR TEMP. VEGETATION • DESIGN/BUILD PROJECTS •
ASSOCIATES ROOFING & CONSTRUCTION, INC.		PO BOX 1986	MURRELLS INLET	SC	29576	(843)357-1713	WANDA@ARCINCORPORATED.ORG	(843)357-0053	CLEARING AND GRUBBING • CONCRETE RDWY JOINT SEALS • BRDG CLEANING AND PAINTING • BRIDGE JACKING • BRIDGE JOINT INSTALL. OR REPAIR • CONCRETE PATCH - STRUCTURES • REBAR - PLACING & TYING • STRUCTURE REMOVAL • EROSION CONTROL • WATERPROOF - SUBSTRY/DECK • SI
ASTRON GENERAL CONTRACTING CO., INC.		PO BOX 1100	DALLAS	NC	28034	(704)923-0644	ADMIN@ASTRONGENERALCONTRACTING.BIZ	(704)923-0646	
ATLANTIC ELECTRIC, LLC		PO BOX 41347	CHARLESTON	SC	29423	(843)460-1200	LRICHARDSON@ATLANTICELECTRIC.COM	(843)552-2719	GENERAL •
B & N GRADING, INC.	DBE	PO BOX 790496	CHARLOTTE	NC	28206	(704)910-4886	BECKY@BNGRADING.COM	(704)910-5705	GENERAL •
B M C O CONSTRUCTION, INC.	DBE	PO BOX 1361	LUMBERTON	NC	28359	(910)738-6693	LEEANN@BMCOCONSTRUCTION.COM	(910)738-4670	GENERAL •
BAGWELL FENCE COMPANY, INC.		PO BOX 2608	SPARTANBURG	SC	29304	(864)582-6786	KGIBBS@BAGWELLFENCE.COM	(864)582-2737	GUARDRAIL-STL BM/CABLE BARR • FENCING •
BALFOUR BEATTY INFRASTRUCTURE, INC.		3314 JAECKEL DRIVE, UNIT 140 W.	WILMINGTON	NC	28403	(910)452-1145	NHUGGINS@BALFOURBEATTYUS.COM	(910)452-1550	GENERAL •
BANKS CONSTRUCTION COMPANY		PO BOX 71505	NORTH CHARLESTON	SC	29415	(843)744-8261	BILL.ZOBEL@BANKSCONSTRUCTION.COM	(843)566-7066	GENERAL •
BEAM'S CONTRACTING, INC.		15030 ATOMIC ROAD	BEECH ISLAND	SC	29842	(803)827-0136	GBANDY@BEAMSCONTRACTING.NET	(803)827-1868	GENERAL •

BEN COX, LLC		PO BOX 137	ANDREWS	SC	29510	(843)264-5947	RON@BENCOSLLC.COM	(843)264-9959	ROAD CONSTRUCTION - NEW • ASPH PAVING & RESURFACING • BASE & SUBBASE WORK • CATCH BASIN, MANHOLES, ETC. • CLEARING AND GRUBBING • CONCRETE SDWLKS & DRIVEWAYS • RDWAY EXCAVATION & GRADING • PERM. OR TEMP. VEGETATION • SHOULDER WIDENING • DESIGN/BUILD PROJE
BENNETT PAVING, INC.		PO BOX 5033	SPARTANBURG	SC	29304	(864)574-3100	CHRIS@BENNETTPAVING.COM	(864)576-7001	ASPH PAVING & RESURFACING • ASPH SURF TREAT (CHIP SEAL) • BASE & SUBBASE WORK • MILLING & GRINDING • PAVING & RESURF - NON HWY •
BENTON CONCRETE & UTILITIES, LLC		PO BOX 797	CONWAY	SC	29528	(843)234-2872	TTYLER@BENTONCONCRETE.COM		CATCH BASIN, MANHOLES, ETC. • CONCRETE PAVING - ROADWAY • CONCRETE SDWLKS & DRIVEWAYS • CURB OR CURB & GUTTER • CONC ROADWAY PATCHING • REBAR - PLACING & TYING • RETAINING WALLS - CIP • CONCRETE WORK - NON-RDWAY •
BLACK CONSTRUCTION COMPANY, LLC		PO BOX 99	LITTLE MOUNTAIN	SC	29075	(803)682-1004	BLACKCONSTRUCTION@BELLSOUTH.NET		CATCH BASIN, MANHOLES, ETC. • CLEARING AND GRUBBING • CONCRETE SDWLKS & DRIVEWAYS • CURB OR CURB & GUTTER • EROSION CONTROL • HAULING CONSTRUCTION MAT • SOIL STABILIZATION•SITE PREP • PAVING & RESURF - NON HWY • PUBLIC UTILITIES INSTALL & REPAIR •
BLOUNT CONSTRUCTION COMPANY, INC.		1730 SANDS PLACE	MARIETTA	GA	30067	(770)541-7333	SHAWN.ENGLAND@BLOUNTCONSTRUCTION.COM	(770)541-7340	GENERAL •
BLYTHE BROTHERS ASPHALT CO., LLC		1415 E. WESTINGHOUSE BLVD	CHARLOTTE	NC	28273	(704)588-0023	KOCONNOR@BLYTHEDEVELOPMENT.COM	(704)588-9935	GENERAL •
BLYTHE CONSTRUCTION, INC.		PO BOX 31635	CHARLOTTE	NC	28231	(704)375-8474	LEE.BRADLEY@BLYTHECONSTRUCTION.COM	(704)375-7814	GENERAL •
BLYTHE CONSTRUCTION/ZACHRY CONSTRUCTION CORP., A JV		PO BOX 31635	CHARLOTTE	NC	28231	(864)546-6530	DAN.HOLYCROSS@BLYTHECONSTRUCTION.COM	(704)375-7814	GENERAL •
BLYTHE DEVELOPMENT CO.		1415 EAST WESTINGHOUSE BLVD.	CHARLOTTE	NC	28273	(704)588-0023	STONEYB@BLYTHEDEVELOPMENT.COM	(704)588-9935	GENERAL •
BOGGS CONTRACTING, INC.		PO BOX 1609	MONROE	NC	28111	(704)289-8482	WDUKE@BOGGS CONTRACTING INC.COM	(704)282-1126	GENERAL •
BOYD UTILITY BORING, INC.		PO BOX 1047	FOREST CITY	NC	28043	(828)245-4041	WENDY@BOYDUTILITYBORING.COM	(828)245-5494	HORIZONTAL JACKING & BORING •
BRANCH CIVIL, INC.		PO BOX 40004	ROANOKE	VA	24022	(540)982-1678	BOB.WILLS@BRANCHGROUP.COM	(540)982-4217	GENERAL •
BRANCH-REEVES JV		PO BOX 40004	ROANOKE	VA	24022	(540)982-1678	BRIAN.EVANS@BRANCHCIVIL.COM		GENERAL •
BRANTLEY CONSTRUCTION SERVICES, LLC		8300 DORCHESTER ROAD	CHARLESTON	SC	29418	(843)552-0150	CHRISTINA@BRANTLEYCONSTRUCTION.COM	(843)552-9072	GENERAL •
BRASFIELD & GORRIE, L.L.C.		P.O. BOX 10383	BIRMINGHAM	AL	35202	(205)328-4000	LALLSOPP@BRASFIELDGORRIE.COM	(204)714-1111	BUILDINGS - NEW OR REHAB. • CONCRETE WORK - NON-RDWAY •
BRAYMAN CONSTRUCTION CORPORATION		1000 JOHN ROEBLING WAY	SAXONBURG	PA	16056	(724)443-1533	R_MANNARINO@BRAYMAN.COM	(724)443-8733	GENERAL •
BRIGGS BROTHERS ENTERPRISES CORPORATION	DBE	413 ODELL INDUSTRIAL WAY	GRIFFIN	GA	30224	(678)749-1375	BRIGGSBROTHERSCG@GMAIL.COM	(678)716-3532	ROAD CONSTRUCTION - NEW • ROADWAY WIDENING • ASPH PAVING & RESURFACING • BASE & SUBBASE WORK • CLEARING AND GRUBBING • CONCRETE PAVING - ROADWAY • CRACK SEALING - ASPHALT RDWAY • CURB OR CURB & GUTTER • ASPHALT ROADWAY PATCHING • GUARDRAIL-STL BM/CABLE BAR
BROCK'S GRADING & LAND CLEARING, LLC		P.O. BOX 115	HARTSVILLE	SC	29551	(843)858-1495	TMIKEBROCK@AOL.COM		ASPH PAVING & RESURFACING • BASE & SUBBASE WORK • CATCH BASIN, MANHOLES, ETC. • CLEARING AND GRUBBING • CONCRETE PAVING - ROADWAY • CONCRETE SDWLKS & DRIVEWAYS • CURB OR CURB & GUTTER • RDWAY EXCAVATION & GRADING • PAVEMENT MARKINGS • EROSION CONTROL • SI
BROOKS-BERRY-HAYNIE & ASSOCIATES, INC.		600 DISCOVERY PLACE	MABLETON	GA	30126	(770)874-1162	TMCCARTY@BBHELECTRIC.COM	(770)874-1171	ROADWAY LIGHTING • TRAFFIC SIGNALS•TRAFFIC SIGNS - PERMANENT • DESIGN/BUILD PROJECTS • CAMERA & ITMS CABLE • AIRPORT RUNWAYS & TAXIWAYS • SITE PREP • RR CONSTRUCTION •
BRTU CONSTRUCTION, INC.		6105 LEES MILL ROAD	FOREST PARK	GA	30297	(404)228-9074	MGZELEKE456@GMAIL.COM	(404)883-3385	GENERAL • GUARDRAIL-STL BM/CABLE BARR • DESIGN/BUILD PROJECTS • FENCING • IMPACT ATTEN/CRASH CUSHIONS •
BULLINGTON CONSTRUCTION, INC.		164 AMERICAN DRIVE	OAKBORO	NC	28129	(704)486-0379	CINDYB@BULLINGTONCONSTRUCTION.COM	(704)486-0389	GENERAL •
C. RAY MILES CONSTRUCTION COMPANY, INC.		PO BOX 1477	LUGOFF	SC	29078	(803)438-9207	SHANNON@CRAYMILES.COM	(803)438-4689	GENERAL •
C.R. JACKSON, INC.		PO BOX 8023	COLUMBIA	SC	29202	(803)750-6070	THAWKINS@CRJACKSON.COM	(803)750-1356	GENERAL •
C.W. MATTHEWS CONTRACTING CO., INC.		PO BOX 970	MARIETTA	GA	30061	(770)422-7520	MMORALES@CWMATTHEWS.COM	(770)422-9361	GENERAL •
CAPE ROMAIN CONTRACTORS, INC.		612 CAPE ROMAIN ROAD	WANDO	SC	29492	(843)884-5167	ACCOUNTING@CAPEROMAINCONTRACTORS.COM	(843)884-0516	GENERAL •
CAPITOL CONSTRUCTION OF THE CAROLINAS, LLC		1554 NAZARETH CHURCH RD.	SPARTANBURG	SC	29301	(864)949-1407	CWELBORN@CAPITOLCONSTRUCTION.US		GENERAL •
CAROLINA INFRASTRUCTURE AND DEVELOPMENT, INC.		130 GARNERS TERRACE ROAD	WEST COLUMBIA	SC	29172	(803)764-4009	E3GRINER@CIDEVELOPMENTINC.COM		GENERAL •
CAROLINA TRAFFIC CONTROLS LLC		368 DAVES ROAD	YORK	SC	29745	(803)371-3215	KCYOUNGBLOOD22@GMAIL.COM		ROADWAY LIGHTING • TRAFFIC SIGNALS•TRAFFIC SIGNS - PERMANENT •
CAROLINA UTILITIES AND SITWORK, LLC		1311 THIRTEENTH AVENUE, UNIT E	CONWAY	SC	29526	(843)488-2012	KRISTINA@CAROLINASITWORKLLC.COM		GENERAL •
CBG, INC.		500 FRONTAGE ROAD	GASTON	SC	29053	(803)791-8457	KHOLLADAY@CBGSITWORK.COM	(803)791-3655	GENERAL •
CCC/BBII JV		PO BOX 30007	CHARLOTTE	NC	28230	(704)348-1394	GELLIS@CROWDERUSA.COM	(704)372-9946	GENERAL •
CEKRA, INC.	DWBE	PO BOX 7964	WILMINGTON	NC	28406	(910)338-3643	OFFICE@CEKRA.COM	(866)983-5798	CONCRETE RDWY JOINT SEALS • BRDG REHAB AND/OR WIDENING • BRDG CLEANING AND PAINTING • BRIDGE JACKING • BRIDGE JOINT INSTALL OR REPAIR • CONCRETE PATCH - STRUCTURES • REBAR - PLACING & TYING • EXPOXY/GROUT CRACK INJECT • TRAFFIC CONTROL SERVICES • CONCRE
CENTRAL SEAL COMPANY		PO BOX 490	DANVILLE	KY	40423	(859)236-2367	CHRIS@CENTRALSEAL.COM	(859)236-2373	PAVEMENT MARKINGS • RAISED PAVEMENT MARKERS • BRDG CLEANING AND PAINTING • WATERPROOF - SUBSTR/DECK • SITE PREP • INDUSTRIAL PAINTING •
CHAMPION INDUSTRIAL, LLC		130 SW 22ND STREET	FORT LAUDERDALE	FL	33315	(954)462-9079	ADOMINGUEZ@CHAMPIONSSC.COM	(954)462-9089	BRDG CLEANING AND PAINTING • BRIDGE JOINT INSTALL OR REPAIR • WATERPROOF - SUBSTR/DECK • INDUSTRIAL PAINTING •
CHAMPION PAINTING SPECIALTY SERVICES CORP.		130 SW 22 STREET	FORT LAUDERSALE	FL	33315	(954)462-9079	ADOMINGUEZ@CHAMPIONSSC.COM	(954)462-9089	BRDG CLEANING AND PAINTING • BRIDGE JOINT INSTALL OR REPAIR • WATERPROOF - SUBSTR/DECK • INDUSTRIAL PAINTING •
CHASE RELINE, INC.		P.O. BOX 21428	CHATTANOOGA	TN	37424	(423)713-7201	AUNDREA@CHASERELINE.US	(423)713-7951	CAMERA & ITMS CABLE • STORM DEBRIS REMOVE •
CHEROKEE, INC.		6928 CHEVAL STREET	COLUMBIA	SC	29209	(803)776-4870	AKYZER@CHEROKEE-SC.COM	(803)776-5507	GENERAL •

CIANBRO CORPORATION		PO BOX 1000	PITTSFIELD	ME	04967	(207)487-3311	SBAGLEY@CIANBRO.COM	(207)679-2465	GENERAL •
CIVIL WORKS CONTRACTING LLC		190 RALEIGH STREET	WILMINGTON	NC	28412	(910)859-8574	ERIVERA@CIVILWORKSCONTRACTING.COM	(910)769-2845	GENERAL •
CLARY HOOD & ASSOCIATES, INC.		150 CONWAY BLACK ROAD	SPARTANBURG	SC	29307	(864)579-8881	ANDY@CLARYHOOD.COM	(864)579-8882	GENERAL •
CLEARWATER CONSTRUCTION, INC. DBA CLEARWATER COASTAL, INC.		1040 PERRY HIGHWAY	MERCER	PA	16137	(724)300-1656	ESTIMATING@CLEARWATERCONSTRUCTION.COM	(888)855-2282	GENERAL •
CLELAND CONSTRUCTORS, INC.		PO BOX 3822	BLUFFTON	SC	29910	(843)987-0500	KSMITH@CLELAND.CO	(843)987-0600	GENERAL •
CLELAND SITE PREP, INC.		PO BOX 3822	BLUFFTON	SC	29910	(843)987-0500	ACLELAND@CLELAND.CO	(843)987-0600	ROAD CONSTRUCTION - NEW • BASE & SUBBASE WORK • CATCH BASIN, MANHOLES, ETC. • CLEARING AND GRUBBING • CONCRETE SDWLKS & DRIVEWAYS • CURB OR CURB & GUTTER • RDWAY EXCAVATION & GRADING • PAVEMENT MARKINGS • TRAFFIC SIGNS - PERMANENT • PERM. OR TEMP. VEGETAT
CNA CONSTRUCTION, INC.		500 MYRTLE BEACH HIGHWAY	SUMTER	SC	29153	(803)495-8988	BBEARDCNA@GMAIL.COM	(803)775-1040	GENERAL •
COASTAL ASPHALT, LLC		2142 WINBURN STREET	CONWAY	SC	29527	(843)397-7325	JON@COASTALASPHALT.COM	(843)397-1888	GENERAL •
COLDITZ TRUCKING, INC.		191 BILL DONALDSON CIRCLE	BLAIRSVILLE	GA	30512	(706)745-6247	COLDITZTRUCKING1@AOL.COM	(706)745-8573	ROAD CONSTRUCTION - NEW • ASPH PAVING & RESURFACING • BASE & SUBBASE WORK • CLEARING AND GRUBBING • CURB OR CURB & GUTTER • RDWAY EXCAVATION & GRADING • CONC ROADWAY PATCHING • MILLING & GRINDING • SHOULDER WIDENING • EROSION CONTROL • SITE PREP •
COMPLETE UTILITIES, LLC		P.O. BOX 660	SCRANTON	SC	29591	(843)210-7473	RUSTY@COMPLETE-UTILITIES.COM	(843)210-7474	ROADWAY WIDENING • ASPH PAVING & RESURFACING • BASE & SUBBASE WORK • CATCH BASIN, MANHOLES, ETC. • CLEARING AND GRUBBING • RDWAY EXCAVATION & GRADING • PILE/DRILLED SHAFT TESTING • STRUCTURE REMOVAL • ON CALL SERVICES • EROSION CONTROL • FENCING • HORIZON
CONDER CONSTRUCTION, INC.		PO BOX 1205	LUGOFF	SC	29078	(803)438-8221	DIANEC.CONDER@GMAIL.COM	(803)438-8772	ROAD CONSTRUCTION - NEW • BASE & SUBBASE WORK • CATCH BASIN, MANHOLES, ETC. • CLEARING AND GRUBBING • CURB OR CURB & GUTTER • RDWAY EXCAVATION & GRADING • EROSION CONTROL • SOIL STABILIZATION•TRAFFIC CONTROL SERVICES • SITE PREP • PAVING & RESURF - NON HW
CONSTRUCTION RESOURCE GROUP, INC.	DWBE	2281 BROWNS CREEK CHURCH ROAD	UNION	SC	29379	(864)674-6750	ABAILER@CRGSC.NET		ROAD CONSTRUCTION - NEW • ASPH PAVING & RESURFACING • RDWAY EXCAVATION & GRADING • TRAFFIC SIGNALS•PERM. OR TEMP. VEGETATION • DESIGN/BUILD PROJECTS • DRILLED SHAFTS/PILE FOUND. • MECH. STABILIZED EARTH WALLS • RETAINING WALLS - CIP • STRUCTURE EXCAVATION
CONTI CIVIL, LLC		2045 LINCOLN HIGHWAY	EDISON	NJ	08817	(732)520-5000	MPEREIRA@CONTICIVIL.COM		GENERAL •
CONTRACTOR SERVICES OF KERSHAW, LLC		PO BOX 127	KERSHAW	SC	29067	(803)475-4598	ADMINISTRATION@CSKERSHAW.COM	(803)475-1118	ASPH PAVING & RESURFACING • CLEARING AND GRUBBING • CONCRETE SDWLKS & DRIVEWAYS • BRIDGE JACKING • BRICK,BLOCK,STONE MASONRY • ENVIRONMENTAL MITIGATION • EROSION CONTROL • FENCING • HAULING CONSTRUCTION MAT • LANDSCAPING & PLANTINGS • SITE PREP • CONCRETE
CP BUILDERS, INC.		PO BOX 161148	BOILING SPRINGS	SC	29316	(864)205-7796	MATT@CPBUILDERSINC.COM		GENERAL •
CROWDER CONSTRUCTION COMPANY		PO BOX 30007	CHARLOTTE	NC	28230	(704)332-8184	GELLIS@CROWDERCC.COM	(704)372-9946	GENERAL•BRIDGES - NEW •
CUTLER REPAVING, INC.		921 E. 27TH STREET	LAWRENCE	KS	66046	(785)843-1524	JCOFFMAN@CUTLERREPAVING.COM	(785)843-3942	ASPH PAVING & RESURFACING • MILLING & GRINDING •
D & L SITEWORK, INC.		6001 CATES BAY HIGHWAY	CONWAY	SC	29527	(843)397-5850	SHANNON@DNLSITEWORK.COM	(843)397-5855	GENERAL •
D. M. CONLON, INC. DBA DAN-KEL CONCRETE CUTTING & CORING	DWBE	PO BOX 7127	MYRTLE BEACH	SC	29572	(843)449-0199	MELISSA@DANKELCONCRETE.COM		ROADWAY WIDENING • CONCRETE RDWY JOINT SEALS • ASPHALT ROADWAY PATCHING • BRIDGES - NEW • BRIDGE REPLACEMENT & APPRS. • BRDG REHAB AND/OR WIDENING • BRIDGE - EMERGENCY REPAIR • BRIDGE JOINT INSTALL OR REPAIR • CONCRETE PATCH - STRUCTURES • ON CALL SERVI
DANE CONSTRUCTION, INC.		PO BOX 800	MOORESVILLE	NC	28115	(704)664-5042	PETE@DANECONSTRUCTION.COM	(704)663-2475	GENERAL •
DANGRADY COMPANY LLC		1517 LITTLE SAVANNAH ROAD	SYLVA	NC	28779	(828)506-0112	NOAH@DANGRADYCO.COM		ROADWAY WIDENING • BASE & SUBBASE WORK • CATCH BASIN, MANHOLES, ETC. • CLEARING AND GRUBBING • SHOULDER WIDENING • CULVERTS - NEW • HAULING CONSTRUCTION MAT • TRAFFIC CONTROL SERVICES • BLDG DEMOLITION & REMOVAL • SITE PREP •
DBS CORPORATION		537 MARKET ST. SUITE 402	CHATANOOGA	TN	37402	(423)752-1302	REGISTRATIONS@DBSCORPORATION.COM		BLDG DEMOLITION & REMOVAL • BUILDINGS - NEW OR REHAB. • SITE PREP •
DEEP SOUTH INDUSTRIAL SERVICES, INC.		PO BOX 30153	ROCKMART	GA	30153	(678)757-1022	GNICHOLS@DEEPSOUTHIND.COM		CRACK SEALING - ASPHALT RDWY •
DELLINGER, INC.		PO BOX 929	MONROE	NC	28111	(704)283-7551	RMEIKER@DELLINGER-INC.COM	(704)289-8217	BRIDGES - NEW • BRIDGE REPLACEMENT & APPRS. • BRDG REHAB AND/OR WIDENING • BRIDGE - EMERGENCY REPAIR • PUBLIC UTILITIES INSTALL & REPAIR •
DIAMOND SURFACE, INC.		21025 COMMERCE BLVD., SUITE 900	ROGERS	MN	55374	(763)420-5009	TERRYH@DIAMONDSURFACEINC.COM	(763)420-5929	CONCRETE RDWY JOINT SEALS • CONC ROADWAY PATCHING • MILLING & GRINDING • REBAR - PLACING & TYING • MILLED-IN RUMBLE STRIPS •
DNR CONSTRUCTION, LLC		475 WILDLIFE ROAD	LEXINGTON	SC	29072	(803)490-0478	DNRCONSTRUCTION@OUTLOOK.COM		GENERAL •
DOBBINS AND CO., INC.		80 ORCHARD ROAD	CAMPOBELLO	SC	29322	(864)590-1793	CODYSWHISPER@AOL.COM		ROAD CONSTRUCTION - NEW • ROADWAY WIDENING • BASE & SUBBASE WORK • CLEARING AND GRUBBING • CONCRETE PAVING - ROADWAY • RDWAY EXCAVATION & GRADING • EROSION CONTROL • AIRPORT RUNWAYS & TAXIWAYS • SITE PREP • PAVING & RESURF - NON HWY •
DON MOORHEAD CONSTRUCTION, INC.		1513 ANDERSON STREET	BELTON	SC	29627	(864)338-0888	beth@moorheadconstruction.com		PUBLIC UTILITIES INSTALL & REPAIR •
DRIGGERS CONSTRUCTION LLC		3536 MCNIEL FARM RAOD	HAMER	SC	29547	(843)841-0891	ERIC@DRIGGERSCONSTRUCTION.COM		ROAD CONSTRUCTION - NEW • ASPH PAVING & RESURFACING • CURB OR CURB & GUTTER • RDWAY EXCAVATION & GRADING • PUBLIC UTILITIES INSTALL & REPAIR •
DURA MARK, INC.		PO BOX 868	AURORA	OH	44202	(330)995-0883	CB@DURAMARKSTRIPING.COM	(330)995-0884	PAVEMENT MARKINGS • RAISED PAVEMENT MARKERS • TRAFFIC CONTROL SERVICES •
DYNAMIC SURFACE APPLICATIONS, LTD		373 VILLAGE ROAD	PENNSDALE	PA	17756	(570)546-6041	MSTACHOWICZ@DSA-LTD.COM	(888)600-0036	CRACK SEALING - ASPHALT RDWY • BRIDGE JOINT INSTALL OR REPAIR •
E. LUKE GREENE COMPANY, INC.		4807 DOUGLAS DAM ROAD	STRAWBERRY PLAINS	TN	37871	(865)933-5902	JOSEPHINE@ELUKEGREENE.COM	(865)933-5063	HAZARDOUS MATERIAL REMOVAL • BLDG DEMOLITION & REMOVAL •
E.R. SNELL CONTRACTOR, INC.		PO BOX 306	SNELLVILLE	GA	30078	(770)985-0600	JLEGETT@ERSNELL.COM	(770)985-2957	GENERAL •
E.S. WAGNER COMPANY LLC		1515 SHOPTON ROAD, SUITE 103	CHARLOTTE	NC	28217	(704)676-9992	ENGINEERING@ESWAGNER.COM	(704)676-9923	GENERAL •

EAGLE CONSTRUCTION COMPANY		PO BOX 132	NEWBERRY	SC	29108	(803)276-5040	JFSPOTTS@EAGLECONSTRUCTIONCO.COM	(803)321-2332	GENERAL •
EARTH MATERIALS GRADING, INC.		PO BOX 664	BELTON	SC	29627	(864)296-4488	EARTHMATERIALS@GMAIL.COM		GENERAL •
EATON CONSTRUCTION COMPANY, INC.	DWBE	PO BOX 684	CIRCLEVILLE	OH	43113	(740)474-3414	DEBBIE.EATON@FRONTIER.COM	(740)474-9616	CONCRETE RDWY JOINT SEALS • PAVEMENT MARKINGS •
ECS DEVELOPEMENT, LLC		1479 MT. LEBANON ROAD	CAMPOBELLO	SC	29322	(864)513-0088	PAUL@ENCHANTEDHOMES.COM		GENERAL •
EDISTO CONTRACTING, LLC		PO BOX 71505	NORTH CHARLESTON	SC	29415	(843)744-8261	BILL.ZOBEL@BANKSCONSTRUCTION.COM	(843)566-7066	GENERAL •
ELECTRICOM, LLC		PO BOX 319	PAOLI	IN	47454	(812)203-3131	CONTRACTS@ELECTRICOMINC.COM		PUBLIC UTILITIES INSTALL & REPAIR •
ELITE CONCRETE CONTRACTING INC.	DBE	105 STANDARD WAREHOUSE ROAD	LUGOFF	SC	29078	(803)572-0566	ARLEN@ELITECONCRETECONTRACTING.COM		CATCH BASIN, MANHOLES, ETC. • CONCRETE PAVING - ROADWAY • CONCRETE SDWLKS & DRIVEWAYS • CURB OR CURB & GUTTER • TRAFFIC CONTROL SERVICES •
ELITE INDUSTRIAL PAINTING, INC.		1505 SAVANNAH AVENUE	TARPON SPRINGS	FL	34689	(727)940-6001	TULA@EIPAINING.COM	(727)279-2827	BRDG CLEANING AND PAINTING • BRIDGE JOINT INSTALL OR REPAIR •
ELMORE LAND & SITE DEVELOPING, INC.		289 COX ROAD	ENOREE	SC	29335	(864)969-2200	RADAWN@ELMORELANDANDSITE.COM		CLEARING AND GRUBBING • RDWAY EXCAVATION & GRADING • PERM. OR TEMP. VEGETATION • CULVERTS - NEW • EROSION CONTROL • SITE PREP • CONCRETE WORK - NON-RDWAY • PUBLIC UTILITIES INSTALL & REPAIR •
EMERY SAPP & SONS, INC.		2301 I-70 DRIVE NW	COLUMBIA	MO	65202	(573)445-8331	MELISSA.MCMILLIN@EMERYSAPP.COM	(573)446-4805	GENERAL •
ENGLISH CONSTRUCTION COMPANY, INCORPORATED		PO BOX P-7000	LYNCHBURG	VA	24505	(434)845-0301	JDALTON@ENGLISHCONST.COM	(434)845-0306	GENERAL •
EUROVIA ATLANTIC COAST LLC		PO BOX 4487	BEAUFORT	SC	29903	(803)791-1295	RONALD.VANVLAKE@EUROVIA.US	(803)791-1965	GENERAL •
EUTAW CONSTRUCTION COMPANY, INCORPORATED		PO BOX 2482	MADISON	MS	39130	(601)855-7474	JHUUST@EUTAW.US	(601)855-7787	GENERAL •
FIRST CONSTRUCTION MANAGEMENT, LLC		1003 E. RECESS ROAD	HANAHAN	SC	29410	(843)647-7434	RANDI@1STMGMT.ORG	(866)929-6916	ASPH PAVING & RESURFACING • BASE & SUBBASE WORK • CATCH BASIN, MANHOLES, ETC. • CONCRETE SDWLKS & DRIVEWAYS • CRACK SEALING - ASPHALT RDWY • CURB OR CURB & GUTTER • MILLING & GRINDING • PAVEMENT MARKINGS • ROADWAY LIGHTING • FENCING • TRAFFIC CONTROL SERV
FLATIRON CONSTRUCTORS, INC.		385 INTERLOCKEN CRESCENT #900	BROOMFIELD	CO	80021	(303)485-4050	JLAWLER@FLATIRONCORP.COM		GENERAL •
FLUOR ENTERPRISES, INC.		100 FLUOR DANIEL DRIVE	GREENVILLE	SC	29607	(864)281-4404	HOPE.GRUMBLES@FLUOR.COM	(864)517-1319	GENERAL •
FREYSSINET, INC.		44880 FALCON PLACE SUITE 100	STERLING	VA	20166	(703)378-2500	REGISTRATION@FREYSSINETUSA.COM	(703)378-2700	GENERAL •
GEARIG CIVILWORKS, LLC		322 GRIMAULD BLVD.	GROVETOWN	GA	30813	(706)860-5981	RYANR@GEARIG.COM	(706)860-9639	GENERAL •
GEMSTONE, LLC		1010 KENNEDY DRIVE STE. 406	KEY WEST	FL	33040	(305)294-3233	RMAPLEDDORAM@GEMSTONELLC.COM	(305)768-0195	BRDG CLEANING AND PAINTING •
GEOSTABILIZATION INTERNATIONAL, LLC		4475 EAST 74TH AVE., SUITE 100	COMMERCE CITY	CO	80022	(970)210-6170	LICENSING@GSI.US	(888)688-6454	CLEARING AND GRUBBING • CURB OR CURB & GUTTER • SHOULDER WIDENING • DESIGN/BUILD PROJECTS • DRILLED SHAFTS/PILE FOUND. • MECH. STABILIZED EARTH WALLS • RETAINING WALLS - CIP • EROSION CONTROL • SOIL STABILIZATION • SHOTCRETING •
GERMAN TECHNICAL GROUP, LLC	DBE	PO BOX 2453	MOUNT PLEASANT	SC	29465	(843)225-2934	elhora@germantechgroup.com	(843)225-7197	ROADWAY LIGHTING • TRAFFIC SIGNALS • TRAFFIC SIGNS - PERMANENT • CAMERA & ITMS CABLE • ON CALL SERVICES • OVERHEAD SIGN STRUCTURES • TRAFFIC CONTROL SERVICES •
GIBSON & ASSOCIATES, INC.		P.O. BOX 800579	BALCH SPRINGS	TX	75180	(972)557-1199	TRISHB@GIBSONASSOC.NET	(972)557-1552	GENERAL •
GLF CONSTRUCTION CORPORATION		1428 BRICKELL AVE., SUITE 100	MIAMI	FL	33131	(305)371-5228	TEGARCIA@GLFUSA.COM	(305)371-9201	GENERAL •
GORDON COMPANY INC.		105 KAYLAN LANE	THOMASVILLE	NC	27360	(336)382-2536	CADDMAX3553@GMAIL.COM		CONCRETE RDWY JOINT SEALS • CRACK SEALING - ASPHALT RDWY • CONC ROADWAY PATCHING •
GRANITE CONSTRUCTION COMPANY		PO BOX 500085	WATSONVILLE	CA	95077	(831)724-1011	ISABEL.BARRON@GCINC.COM	(831)768-4021	GENERAL •
GRANT ELECTRICAL CONTRACTING, LLC	DBE	PO BOX 7368	WEST COLUMBIA	SC	29171	(803)936-0071	GRANTELECTRICALCONTRACTING@YAHOO.COM	(803)936-0074	ROADWAY LIGHTING • TRAFFIC SIGNALS •
GREEN WAVE CONTRACTING, INC.		3989 HIGHMARKET STREET	GEORGETOWN	SC	29440	(843)485-4203	MAIL@GREENWAVECONTRACTING.COM	(800)996-0715	ASPH PAVING & RESURFACING • BASE & SUBBASE WORK • CATCH BASIN, MANHOLES, ETC. • CLEARING AND GRUBBING • CONCRETE PAVING - ROADWAY • CONCRETE SDWLKS & DRIVEWAYS • CURB OR CURB & GUTTER • RDWAY EXCAVATION & GRADING • MILLING & GRINDING • PERM. OR TEMP. VEGE
GREENWALL CONSTRUCTION SERVICE, INC.		PO BOX 30490	MYRTLE BEACH	SC	29588	(843)236-7800	VICKIE@GREENWALLCONST.COM	(843)236-4418	ASPH PAVING & RESURFACING • BASE & SUBBASE WORK • CATCH BASIN, MANHOLES, ETC. • CLEARING AND GRUBBING • CONCRETE SDWLKS & DRIVEWAYS • CURB OR CURB & GUTTER • ASPHALT ROADWAY PATCHING • MILLING & GRINDING • PAVEMENT MARKINGS • PERM. OR TEMP. VEGETATION • S
GULF COAST CONTRACTING, LLC		PO BOX 2178	TARPON SPRINGS	FL	34688	(727)938-6081	ADMIN@GULFCASTOFFL.COM	(727)937-0967	BRDG CLEANING AND PAINTING • BRIDGE JOINT INSTALL OR REPAIR • CONCRETE BARRIERS - CIP • HAZARDOUS MATERIAL REMOVAL • TRAFFIC CONTROL SERVICES • CONCRETE WORK - NON-RDWAY • INDUSTRIAL PAINTING •
GULF COAST UNDERGROUND, LLC		5655 MIDDLE ROAD	THEODORE	AL	26582	(251)725-0200	DDAVIS@GOGCU.COM	(866)471-2753	GENERAL •
GULF STREAM CONSTRUCTION COMPANY, INC.		1983 TECHNOLOGY DRIVE	CHARLESTON	SC	29492	(843)572-4363	MBLACKWOOD@GULFSTREAMCONSTRUCTION.COM	(843)572-9609	GENERAL •
HARBOUR CONTRACTORS, INC.		23830 W. MAIN STREET	PLAINFIELD	IL	60544	(815)254-5500	SCEBALLOS@HARBOUR-CM.COM	(815)254-5505	BUILDINGS - NEW OR REHAB. • RR CONSTRUCTION •
HAYNES ELECTRIC UTILITY, A DIVISION OF MB HAYNES CORPORATION		PO BOX 16589	ASHVILLE	NC	28816	(828)254-6141	NTAYLOR@MBHAYNES.COM		ROADWAY LIGHTING • TRAFFIC SIGNALS • CAMERA & ITMS CABLE •
HENLEY'S CONSTRUCTION CO., INC.		2876 HIGHWAY 9 WEST	CHERAW	SC	29520	(843)537-5924	HENLEY.JONES@HENLEYGROUP.COM	(843)537-5646	CONCRETE SDWLKS & DRIVEWAYS • CURB OR CURB & GUTTER • FENCING • HARDSCAPES/STREETSCAPES • WATERPROOF - SUBSTR/DECK • BLDG DEMOLITION & REMOVAL • BUILDINGS - NEW OR REHAB. • CONCRETE WORK - NON-RDWAY •
HGS, LLC DBA RES ENVIRONMENTAL OPERATING COMPANY, LLC		3600 GLENWOOD AVENUE, SUITE 100	RALEIGH	NC	27612	(713)520-5400	JPOE@RES.US	(713)520-5400	CLEARING AND GRUBBING • PERM. OR TEMP. VEGETATION • DESIGN/BUILD PROJECTS • DREDGING /CHANNEL CLEARING • ENVIRONMENTAL MITIGATION • EROSION CONTROL • HARDSCAPES/STREETSCAPES • LANDSCAPING & PLANTINGS • MOWING/VEG CONTROL • STORM DEBRIS REMOVE •
HIGH BRANCH SERVICES, LLC		1169 ROYLE ROAD, SUITE C	LADSON	SC	29456	(843)900-3190	HIGHBRANCHSERVICES@GMAIL.COM		GENERAL •

HI-WAY PAVING, INC.		PO BOX 550	HILLIARD	OH	43026	(614)876-1700	MBOWMAN@HIWAYPAVING.COM	(614)876-1899	GENERAL •
HUBBARD PAVING & GRADING, INC.		698 ROCK CRUSHER ROAD	WALHALLA	SC	29691	(864)638-8672	HUBBARDPAVING@YAHOO.COM	(864)638-8672	ASPH PAVING & RESURFACING • SHOULDER WIDENING • PAVING & RESURF - NON HWY • ROAD CONSTRUCTION - NEW • ROADWAY WIDENING • ASPH PAVING & RESURFACING • FULL DEPTH RECLAMATION • ASPHALT ROADWAY PATCHING •
IN LINE PAVING INDUSTRIES, LLC		161 CHURCH VIEW COURT	LEXINGTON	SC	29073	(803)996-0565	INLINEPAVING@LIVE.COM	(803)356-0655	
INDEPENDENCE EXCAVATING, INC.		5720 E. SCHAAF ROAD	INDEPENDENCE	OH	44131	(216)524-1700	DOTQUALS@INDEXC.COM		GENERAL •
INLINER SOLUTIONS, LLC		1510 KLONDIKE ROAD, SUITE 400	CONYERS	GA	30094	(704)504-8464	RYAN.OSHLO@PURISCORP.COM	(704)504-9272	PUBLIC UTILITIES INSTALL & REPAIR •
INTERCOASTAL MARINE, LLC		639 OLD US 52 SOUTH	MOUNT AIRY	NC	27030	(336)789-8221	JODY@SMITHROWE.COM	(336)789-6807	GENERAL •
INTERNATIONAL RIGGING GROUP, LLC		20 HIBISCUS STREET	TARPON SPRINGS	FL	34689	(727)938-6557	TMARKAL@INTLRIGGING.COM	(727)942-1450	BRDG CLEANING AND PAINTING •
INTERSTATE IMPROVEMENT, INC.		PO BOX 8	FARIBAUT	MN	55021	(507)333-2677	TDETMASO@INTERSTATEIMPROVEMENT.COM	(507)333-3901	GENERAL •
INTERSTATE SEALANT & CONCRETE, INC.	DWBE	540 W24211 ROCKWOOD WAY	WAUKESHA	WI	53189	(262)547-6316	CSMENT@INTERSTATESEALANT.COM	(262)547-6844	CONCRETE RDWY JOINT SEALS • AIRPORT RUNWAYS & TAXIWAYS •
IOWA CIVIL CONTRACTING, INC.		P.O. BOX Q	VICTOR	IA	52347	(319)647-3561	TERIN@IOWACVIL.COM	(319)647-2376	GENERAL •
IPC PAVING LLC		2000 SPARTANBURG HIGHWAY, SUITE 600	HENDERSONVILLE	NC	28792	(828)552-3233	ACREASMAN@IPCSTRUCTURE.COM		GENERAL •
IPW CONSTRUCTION GROUP, LLC	DBE	PO BOX 40968	CHARLESTON	SC	29423	(843)308-0524	CYRUSSINOR@IPWCO.COM	(843)308-6650	GENERAL •
IRON CITY ITS SERVICES, LLC		PO BOX 1537	GAFFNEY	SC	29342	(864)415-2071	DBOLTON@IRONCITYITS.COM	(864)206-0105	CLEARING AND GRUBBING • ROADWAY LIGHTING • TRAFFIC SIGNALS•TRAFFIC SIGNS - PERMANENT • CAMERA & ITMS CABLE • ON CALL SERVICES • FENCING • HAULING CONSTRUCTION MAT • OVERHEAD SIGN STRUCTURES • TRAFFIC CONTROL SERVICES • MARINE DOCKS, FENDERS, ETC. •
IVS HYDRO INC.		PO BOX 245	WAVERLY	WV	26184	(304)464-4340	CHRISTINE.LEE@IVSGROUP.COM	(304)464-5612	GENERAL •
J. B. COXWELL CONTRACTING, INC.		6741 LLOYD ROAD WEST	JACKSONVILLE	FL	32254	(904)786-1120	TRACYK@JBCOXWELL.COM	(904)783-2970	GENERAL •
J. C. WILKIE CONSTRUCTION, LLC		PO BOX 1350	LEXINGTON	SC	29071	(803)808-3220	AMANDA@JCWILKIELL.COM	(803)808-3262	GENERAL •
J. FLETCHER CREAMER & SON, INC.		101 EAST BROADWAY	HACKENSACK	NJ	07601	(201)488-9800	SAM.CHANG@JFCSON.US	(201)488-2901	GENERAL •
J. M. WILKERSON CONSTRUCTION CO., INC.		1734 SANDS PLACE	MARIETTA	GA	30067	(770)953-2659	JCURETON@JMWILKERSON.COM	(770)933-9665	GENERAL •
J. R. WILSON CONSTRUCTION CO., INC.		PO BOX 919	VARNVILLE	SC	29944	(803)943-3311	JACKERMAN@JRWILSONCONSTRUCTION.COM	(803)943-3694	GENERAL •
J. T. RUSSELL AND SONS, INCORPORATED		PO BOX 670	ALBEMARIE	NC	28002	(704)982-2225	KCRUSSELL@JTRUSSELLANDSONS.COM	(704)986-2270	GENERAL •
J.D. GASKINS CONSTRUCTION INC.		PO BOX 5717	AIKEN	SC	29804	(803)641-4068	CONSTRUCT@JDGASKINS.COM	(803)641-4069	BUILDINGS - NEW OR REHAB. • CONCRETE WORK - NON-RDWY • MARINE DOCKS, FENDERS, ETC. • PUBLIC UTILITIES INSTALL & REPAIR •
JAY CASHMAN, INC.		549 SOUTH STREET	QUINCY	MA	02169	(617)890-0600	DCALLAHAN@JAYCASHMAN.COM	(617)890-0606	GENERAL •
JHC CORPORATION		15 FRESH BRU DRIVE	NEWNAN	GA	30263	(770)487-3258	JIM@JHCCORPORATION.COM	(770)487-4254	GENERAL •
JOHN R. JURGENSEN COMPANY		11641 MOSTELLER ROAD	CINCINNATI	OH	45241	(513)771-0820	SARA.JONES@JRINET.COM	(513)771-2678	GENERAL •
JOHNSON BROS. CORPORATION, A SOUTHLAND COMPANY		1100 KUBOTA DRIVE	GRAPEVINE	TX	76051	(817)293-4263	LICENSE.REG@SOUTHLANDHOLDINGS.COM	(817)293-5065	GENERAL •
JOHNSON-LAUX CONSTRUCTION, LLC		201 SIGMA DRIVE, SUITE 300	SUMMERVILLE	SC	29486	(912)480-0580	KEVIN@JOHNSON-LAUX.COM	(912)480-0580	GENERAL •
K. WEST GROUP, LLC		8305 FREMONT PIKE	PERRYSBURG	OH	43551	(419)874-4284	RYANODENDAHL@KWESTGROUP.COM	(419)874-4306	GENERAL •
K.V.K. CONTRACTING, INC.		727 WESLEY AVENUE	TARPON SPRINGS	FL	34689	(727)934-9984	KATERINAM@KVKCONTRACTINGINC.COM	(727)934-9985	BRDG CLEANING AND PAINTING • CONCRETE PATCH - STRUCTURES • HAZARDOUS MATERIAL REMOVAL • TRAFFIC CONTROL SERVICES • INDUSTRIAL PAINTING • RDWAY EXCAVATION & GRADING • DRILLED SHAFTS/PILE FOUND. • STRUCTURE EXCAVATION • EPOXY/GROUT CRACK INJECT • SOIL STABILIZATION•
KELLER NORTH AMERICA, INC.		7550 TEAGUE ROAD, SUITE 300	HANOVER	MD	21076	(410)551-8200	LICENSING@KELLER-NA.COM	(410)799-3786	
KIEWIT INFRASTRUCTURE SOUTH CO.		1550 MIKE FAHEY STREET	OMAHA	NE	68102	(402)342-2052	JULIE.MUMFORD@KIEWIT.COM	(402)536-3607	GENERAL •
KING ASPHALT, INC.		PO BOX 179	LIBERTY	SC	29657	(864)855-0338	GREG@KINGASPHALTINC.COM	(864)843-2147	GENERAL •
KING CONSTRUCTION SERVICES, INC.		111 WHITE OAK FOREST PLACE	CONWAY	SC	29527	(843)397-8000	WREN@KINGCSINC.COM	(843)397-1505	GENERAL •
KLICOS PAINTING COMPANY, INC.		1501 SOUTH PINELLAS AVE., #N	TARPON SPRINGS	FL	34689	(727)940-5052	DEBBIE@KLICOSPAINT.COM	(727)940-4797	BRDG CLEANING AND PAINTING • ROADWAY LIGHTING • TRAFFIC SIGNALS•CAMERA & ITMS CABLE • AIRPORT RUNWAYS & TAXIWAYS • PUBLIC UTILITIES INSTALL & REPAIR •
KOBO UTILITY CONSTRUCTION CORP.		PO BOX 578	SANDWICH	MA	02563	(508)888-2255	REBECCA@KOBOUTILITY.COM	(508)888-2224	
L & B DEVELOPERS, LLC		315 EAST FRIENDFIELD ROAD	COWARD	SC	29530	(843)389-7005	LANDBDEVELOPERS@YAHOO.COM	(843)389-7006	GENERAL •
L & L CONTRACTORS, INC.		510 WEST MAIN STREET	ANDREWS	SC	29510	(843)264-2450	BJLAMBERT@LLCONTRACTORS.COM	(843)264-6760	GENERAL •
L. DEAN WEAVER COMPANY LLC		1100 PARK WEST BLVD	MOUNT PLEASANT	SC	29466	(843)352-2122	LYNIEL@LDWINC.COM	(843)352-2925	GENERAL •
LAND MECHANIC DESIGNS, INC.		126 CIRCLE G. LANE	WILLOW SPRING	NC	27592	(919)639-6132	LMDC@OUTLOOK.COM	(919)639-7079	BASE & SUBBASE WORK • CLEARING AND GRUBBING • RDWAY EXCAVATION & GRADING • PERM. OR TEMP. VEGETATION • STRUCTURE EXCAVATION • STRUCTURE REMOVAL • CULVERTS - NEW • DREDGING /CHANNEL CLEARING • ENVIRONMENTAL MITIGATION • EROSION CONTROL • MOWING/VEG CONTROL
LANDMARK CONSTRUCTION COMPANY, INC.		3255 INDUSTRY DRIVE	NORTH CHARLESTON	SC	29418	(843)552-6186	SHAYES@LANDMARK-SC.COM	(843)268-0973	GENERAL •

LANFORD BROTHERS COMPANY, INC.		PO BOX 7330	ROANOKE	VA	24019	(540)992-2140	BRETT@LANFORDBROS.COM	(540)992-2139	BRDG REHAB AND/OR WIDENING • BRIDGE JOINT INSTALL. OR REPAIR • CONCRETE PATCH - STRUCTURES • NON-AC OVERLAY - BR. DECKS • REBAR - PLACING & TYING • WATERPROOF - SUBSTR/DECK • CONCRETE WORK - NON-RDWAY • SHOTCRETING •
LCI-LINEBERGER CONSTRUCTION, INC.	DWBE	PO DRAWER 1239	LANCASTER	SC	29721	(803)286-5555	KIM@LCI-LINEBERGER.COM	(803)286-5051	ROAD CONSTRUCTION - NEW • ASPH PAVING & RESURFACING • FULL DEPTH RECLAMATION • BASE & SUBBASE WORK • CLEARING AND GRUBBING • CONCRETE SDWLKS & DRIVEWAYS • CURB OR CURB & GUTTER • RDWAY EXCAVATION & GRADING • ASPHALT ROADWAY PATCHING • PAVEMENT MARKINGS •
LEE CONSTRUCTION COMPANY OF THE CAROLINAS, INC.		633 EAGLETON DOWNS DRIVE	PINEVILLE	NC	28134	(704)588-5272	RPSHAW@LEEACAROLINAS.COM	(704)588-1535	ROADWAY WIDENING • ASPH PAVING & RESURFACING • BASE & SUBBASE WORK • CLEARING AND GRUBBING • CONCRETE RDWY JOINT SEALS • CONCRETE SDWLKS & DRIVEWAYS • CRACK SEALING - ASPHALT RDWY • CURB OR CURB & GUTTER • RDWAY EXCAVATION & GRADING • GUARDRAIL-STL BM/CAB
LIBERTY MAINTENANCE, INC.		777 N. MERIDIAN ROAD	YOUNGSTOWN	OH	44509	(330)755-7711	CK@LIBERTYMAINTENANCEINC.COM	(330)755-1847	BRDG CLEANING AND PAINTING • BRIDGE JOINT INSTALL. OR REPAIR •
LINDLERS CONSTRUCTION OF SOUTH CAROLINA, LLC	DWBE	PO BOX 731	NEWBERRY	SC	29108	(803)276-6557	HEATHER@LINDLERS.COM		ROAD CONSTRUCTION - NEW • ROADWAY WIDENING • ASPH PAVING & RESURFACING • BASE & SUBBASE WORK • CATCH BASIN, MANHOLES, ETC. • CLEARING AND GRUBBING • CURB OR CURB & GUTTER • RDWAY EXCAVATION & GRADING • MILLING & GRINDING • PERM. OR TEMP. VEGETATION • STRU
LITTLE MOUNTAIN BUILDERS OF CATAWBA COUNTY, INC.		5843 NC16 BUSINESS HWY	MAIDEN	NC	28650	(704)489-6403	LITTLEMTNBLDR@GMAIL.COM	(704)483-1175	CATCH BASIN, MANHOLES, ETC. • CLEARING AND GRUBBING • CONCRETE PAVING - ROADWAY • CONCRETE SDWLKS & DRIVEWAYS • CURB OR CURB & GUTTER • CONC ROADWAY PATCHING • GUARDRAIL-STL BM/CABLE BARR • PAVEMENT MARKINGS • TRAFFIC SIGNS - PERMANENT •
LITTLE MOUNTAIN CONTRACTING, LLC		PO BOX 182	LITTLE MOUNTAIN	SC	29075	(803)622-0748	RD@LMCSC.US		RETAINING WALLS • CONCRETE SDWLKS & DRIVEWAYS • CURB OR CURB & GUTTER • PAVEMENT MARKINGS • ROADWAY LIGHTING • TRAFFIC SIGNALS • TRAFFIC SIGNS - PERMANENT • REBAR - PLACING & TYING • CAMERA & ITMS CABLE • ON CALL SERVICES •
L-I, INC.		615 KNOX ABBOTT DRIVE, SUITE 200	CAYCE	SC	29033	(803)929-1181	SCRANE@L-IINC.COM	(803)929-7625	GENERAL•
LONG FOUNDATION DRILLING CO.		3014 BRANDAU ROAD	HERMITAGE	TN	37076	(615)885-5664	CJOHNSON@LFDC.COM	(615)885-4863	DRILLED SHAFTS/PILE FOUND. •
LOVIN CONTRACTING COMPANY, INC.		937 TALLULAH ROAD	ROBBINSVILLE	NC	28771	(828)479-9462	KBURDETTE@LOVINCONTRACTING.COM	(828)479-6844	CLEARING AND GRUBBING • MILLING & GRINDING • EROSION CONTROL • MOWING/VEG CONTROL •
LOWCOUNTRY SITEWORK, LLC		1023 CLEMENTS FERRY ROAD	CHARLESTON	SC	29492	(843)336-5085	JOHNM@LCSITEWORK.COM	(843)375-2202	GENERAL•
LU, INCORPORATED		PO BOX 607	KINGSTON SPRINGS	TN	37082	(615)952-5501	WARREN.COOK@GUIDERAIL.COM	(615)952-9044	GUARDRAIL-STL BM/CABLE BARR • TRAFFIC SIGNS - PERMANENT • FENCING • IMPACT ATTEN/CRASH CUSHIONS • OVERHEAD SIGN STRUCTURES • TRAFFIC CONTROL SERVICES •
LYNCHEs RIVER CONTRACTING, INC.		PO BOX 250	PAGELAND	SC	29728	(843)675-4285	THAD.PRESLAR@LYNCHEsRIVERCONTRACTING.COM	(843)675-7344	ROADWAY WIDENING • ASPH PAVING & RESURFACING • ASPH SURF TREAT (CHIP SEAL) • FULL DEPTH RECLAMATION • BASE & SUBBASE WORK • CATCH BASIN, MANHOLES, ETC. • CONCRETE RDWY JOINT SEALS • CURB OR CURB & GUTTER • RDWAY EXCAVATION & GRADING • ASPHALT ROADWAY PATC
LYNN THOMAS GRADING, INC.	DWBE	230 ROCKY RIVER CHURCH ROAD	POLKTON	NC	28135	(704)826-8234	FTHOMAS@LYNNTHOMASGRADING.COM	(704)826-8325	GENERAL•
LYNNSTAR CONSTRUCTION COMPANY, INC.	DWBE	PO BOX 15004	GREENVILLE	SC	29610	(803)414-5022	LYNNSTAR@CHARTER.NET		ASPH PAVING & RESURFACING • BASE & SUBBASE WORK • CATCH BASIN, MANHOLES, ETC. • CLEARING AND GRUBBING • CONCRETE SDWLKS & DRIVEWAYS • CURB OR CURB & GUTTER • RDWAY EXCAVATION & GRADING • ASPHALT ROADWAY PATCHING • PAVEMENT MARKINGS • SHOULDER WIDENING • E
M & J CONSTRUCTION CO. OF PINELLAS COUNTY, INC.		809 S. SAFFORD AVENUE	TARPON SPRINGS	FL	34689	(727)938-6478	RECEPTIONIST@MJCONSTRUCTION.NET	(727)934-4665	BRDG REHAB AND/OR WIDENING • BRDG CLEANING AND PAINTING • BRIDGE JACKING • BRIDGE JOINT INSTALL. OR REPAIR • CONCRETE PATCH - STRUCTURES •
M&M SERVICES COMPANY, INC.		228 MIDLAND ATRAIL	MOUNT STERLING	KY	40353	(859)499-3201	JEFF@MMSERVICESKY.COM	(859)499-3221	ASPH PAVING & RESURFACING • MILLING & GRINDING • PAVEMENT MARKINGS • BRDG REHAB AND/OR WIDENING • BRIDGE JOINT INSTALL. OR REPAIR • CONCRETE PATCH - STRUCTURES • NON-AC OVERLAY - BR. DECKS • REBAR - PLACING & TYING • EXPOXY/GROUT CRACK INJECT • EROSION C
MANOLIS PAINTING, INC.		PO BOX 9710	BALDWIN	MD	21013	(410)276-1369	EVELYNS@MANOLISPAINTINGINC.COM	(410)327-6335	BRDG CLEANING AND PAINTING • REBAR - PLACING & TYING • HAZARDOUS MATERIAL REMOVAL • INDUSTRIAL PAINTING •
MANSON CONSTRUCTION CO.		PO BOX 24067	SEATTLE	WA	98124	(206)762-0850	PROPOSALS@MANSONCONSTRUCTION.COM	(206)764-8595	DESIGN/BUILD PROJECTS • BRIDGES - NEW • BRIDGE - EMERGENCY REPAIR • DRILLED SHAFTS/PILE FOUND. • STRUCTURE REMOVAL • DREDGING /CHANNEL CLEARING • COFFERDAMS & SHEETPIILING • EROSION CONTROL • SOIL STABILIZATION•CONCRETE WORK - NON-RDWAY • MARINE DOCKS, FEND
MARTIN & SON CONTRACTING, INC.		194 MARTIN FAMILY ROAD	SPARTANBURG	SC	29306	(864)583-7935	DWAYNEMARTIN62@YAHOO.COM	(864)583-0429	ASPH PAVING & RESURFACING • BASE & SUBBASE WORK • CATCH BASIN, MANHOLES, ETC. • CLEARING AND GRUBBING • CONCRETE SDWLKS & DRIVEWAYS • CURB OR CURB & GUTTER • RDWAY EXCAVATION & GRADING • ASPHALT ROADWAY PATCHING • STRUCTURE EXCAVATION • STRUCTURE REMOVAL
MARTIN BROTHERS CONSTRUCTION CO., INC.		PO BOX 302	GRAY COURT	SC	29645	(864)876-2634	BMIMMS@MBCINC.COM	(864)876-2695	BASE & SUBBASE WORK • CATCH BASIN, MANHOLES, ETC. • CLEARING AND GRUBBING • TRAFFIC SIGNS - PERMANENT • PERM. OR TEMP. VEGETATION • EROSION CONTROL • HAULING CONSTRUCTION MAT • SITE PREP •
MASSANA CONSTRUCTION, INC.		115 HOWELL RD	TYRONE	GA	30290	(770)632-2081	CHENEY@MASSANACONSTRUCTION.COM	(770)632-2082	GENERAL•
MASSMAN CONSTRUCTION CO.		4400 W. 109TH STREET, #300	OVERLAND PARK	KS	66211	(913)291-2600	AHINKLE@MASSMAN.NET	(913)291-2601	GENERAL•
MASTEC CIVIL, LLC		10790 NW 127 STREET	MEDLEY	FL	33178	(305)670-7585	TBOWMAN@MASTEC-CIVIL.COM	(305)670-7462	GENERAL•
MATTHEWS CONSTRUCTION CO.		PO BOX 36576	ROCK HILL	SC	29732	(803)366-4159	JAYMATTHEWS@MATTHEWSCONSTRUCTIONCO.COM	(803)366-6949	GENERAL•
MCCLAIN & COMPANY, INC.		19152 GERMANNIA HIGHWAY	CULPEPER	VA	22701	(540)423-1110	JKURUCZ@MCCLAIN1.COM	(540)423-1066	TRAFFIC SIGNS - PERMANENT • BRIDGE REPLACEMENT & APPRS. • BRDG CLEANING AND PAINTING • STRUCTURE REMOVAL •
MCCLAM & ASSOCIATES, INC.		1642 HOLY TRINITY CHURCH ROAD	LITTLE MOUNTAIN	SC	29075	(803)345-9194	SNOLFF@MCCLAM.NET	(803)345-5362	ROAD CONSTRUCTION - NEW • ROADWAY WIDENING • ASPH PAVING & RESURFACING • BASE & SUBBASE WORK • CATCH BASIN, MANHOLES, ETC. • CLEARING AND GRUBBING • CONCRETE PAVING - ROADWAY • CONCRETE SDWLKS & DRIVEWAYS • CURB OR CURB & GUTTER • RDWAY EXCAVATION & GRADI
MCLEAN CONTRACTING COMPANY		6700 MCLEAN WAY	GLEN BURNIE	MD	21060	(410)553-6700	LHENEHAN@MCLEANCONTRACTING.COM	(410)766-3860	GENERAL•
METRO DWELLING, LLC		141-F PELHAM ROAD 110	COLUMBIA	SC	29016	(803)750-1388	KEVIN.GILES@METRODWELLINGSLLC.COM	(803)752-0544	CONCRETE SDWLKS & DRIVEWAYS • BUILDINGS - NEW OR REHAB. •
METROPOWER, INC.		PO BOX 5228	ALBANY	GA	31706	(229)432-7345	FRANCES.WHITE@METROPOWER.COM	(229)436-3869	ROADWAY LIGHTING • TRAFFIC SIGNALS•TRAFFIC SIGNS - PERMANENT • DESIGN/BUILD PROJECTS •

MIDWEST MOLE, INC.		6814 WEST 350 N.	GREENFIELD	IN	46140	(317)545-1335	JOANNE@MIDWESTMOLE.COM	(317)545-1558	HORIZONTAL JACKING & BORING • PUBLIC UTILITIES INSTALL & REPAIR • ROAD CONSTRUCTION - NEW • BASE & SUBBASE WORK • CATCH BASIN, MANHOLES, ETC. • CLEARING AND GRUBBING • CULVERTS - NEW • BRICK,BLOCK,STONE MASONRY • EROSION CONTROL • FENCING • HAULING CONSTRUCTION MAT • SITE PREP • PUBLIC UTILITIES INSTALL & REPAIR •
MNB CONSTRUCTION INC.		PO BOX 250	SCRANTON	SC	29591	(843)389-5742	MNBCONSTRUCTIONINC@YAHOO.COM	(843)389-5740	BRDG CLEANING AND PAINTING •
MONOKO, LLC		760 BAYSHORE DRIVE	TARPON SPRINGS	FL	34689	(727)940-3244	MONOKOLLC@AOL.COM		BRDG CLEANING AND PAINTING •
MORGAN CONTRACTING, INC.		PO BOX 5009	KNOXVILLE	TN	37928	(865)249-8640	NORMAG@MORGAN1.COM	(865)249-8651	GENERAL•
MORGAN CORP.		PO BOX 3555	SPARTANBURG	SC	29304	(864)433-8800	CALLEN@MORGAN-CORP.COM	(864)433-8808	GENERAL•
MOSELEY BROS. ASPHALT, LLC		PO BOX 5750	ANDERSON	SC	29623	(864)932-0621	BILLINGS@MOSELEYBROSASPHALT.COM		ASPH PAVING & RESURFACING •
MOUNTAIN CREEK CONTRACTORS, INC.		205 EAST CENTRAL AVENUE	CATAWBA	NC	28609	(828)241-2047	AWYATT@MTCREEKINC.COM		GENERAL•
NAVCON, LLC		828 TUCKER COURT, SUITE A	WINDER	GA	30680	(770)554-1190	TOYA@NAVCON.NET	(770)554-1779	BRICK,BLOCK,STONE MASONRY • CAMERA & ITMS CABLE • AIRPORT RUNWAYS & TAXIWAYS •
NHM CONSTRUCTORS, INC.		PO BOX 6385	ASHEVILLE	NC	28816	(828)670-6652	BNEWMAN@NHMCONSTRUCTORS.COM	(828)670-6636	GENERAL•
NICKELSTON INDUSTRIES, INC.		PO BOX 133	LAWSONVILLE	NC	27022	(336)871-3435	SHEREE@NICKINDUSTRIESINC.COM	(336)871-3439	GUARDRAIL-STL BM/CABLE BARR • SHOULDER WIDENING • FENCING • HAULING CONSTRUCTION MAT • IMPACT ATTEN/CRASH CUSHIONS •
NORTH STAR PAINTING COMPANY, INC.		3526 MCCARTNEY ROAD	YOUNGSTOWN	OH	44505	(330)743-2333	KBENEDICT@NORTHSTARPAINTINGCO.COM	(330)743-3434	BRDG CLEANING AND PAINTING •
OGLESBY CONSTRUCTION, INC.		1600 TOLEDO ROAD	NORWALK	OH	44857	(419)668-8204	TONYW@OGLESBY.NET	(419)660-0160	CONCRETE SDWLKS & DRIVEWAYS • CURB OR CURB & GUTTER • ASPHALT ROADWAY PATCHING • PAVEMENT MARKINGS • RAISED PAVEMENT MARKERS • CONCRETE BARRIERS - CIP •
OLYMPUS PAINTING CONTRACTORS, INC.		556 ANCLOTE ROAD	TARPON SPRINGS	FL	34689	(727)942-4149	GRACE@OLYMPUSPAINTING.COM	(727)938-6297	GUARDRAIL-STL BM/CABLE BARR • BRDG REHAB AND/OR WIDENING • BRDG CLEANING AND PAINTING • BRIDGE JOINT INSTALL OR REPAIR • CONCRETE PATCH - STRUCTURES • EROSION CONTROL • HAULING CONSTRUCTION MAT • HAZARDOUS MATERIAL REMOVAL •
ORION MARINE CONSTRUCTION, INC.		1715 WESTSHORE BLVD., SUITE 875	TAMPA	FL	33607	(813)839-8441	NTHREATT@ORIONMARINEGROUP.COM		BASE & SUBBASE WORK • CLEARING AND GRUBBING • CURB OR CURB & GUTTER • DESIGN/BUILD PROJECTS • BRIDGES - NEW • BRDG REHAB AND/OR WIDENING • CONCRETE PATCH - STRUCTURES • DRILLED SHAFTS/PILE FOUND. • REBAR - PLACING & TYING • STRUCTURE EXCAVATION • DREDGIN
OWENS-FISHER CONSTRUCTION CO., INC.		303 MCLEE RD	LEXINGTON	SC	29073	(803)951-3927	CHARLIE@OWENS-FISHER.COM	(803)951-8819	GENERAL•
PALMETTO CONSTRUCTION MANAGEMENT, LLC		1030 BYPASS 25 NE	GREENWOOD	SC	29649	(864)450-9155	STEVE@PALCM.COM	(864)323-0203	ASPH PAVING & RESURFACING • CATCH BASIN, MANHOLES, ETC. • CLEARING AND GRUBBING • CONCRETE SDWLKS & DRIVEWAYS • CURB OR CURB & GUTTER • ASPHALT ROADWAY PATCHING • CULVERTS - NEW • ON CALL SERVICES • EROSION CONTROL • HAULING CONSTRUCTION MAT • SOIL STABIL
PALMETTO CORP. OF CONWAY		PO BOX 346	CONWAY	SC	29528	(843)365-2156	SGODWIN@PALMETTOCORP.COM	(843)365-5436	ROADWAY WIDENING • ASPH PAVING & RESURFACING • BASE & SUBBASE WORK • CATCH BASIN, MANHOLES, ETC. • CONCRETE SDWLKS & DRIVEWAYS • CURB OR CURB & GUTTER • RDWAY EXCAVATION & GRADING • ASPHALT ROADWAY PATCHING • MILLING & GRINDING • PERM. OR TEMP. VEGETATION
PALMETTO GROUP CONTRACTING, INC.		138 PARK GATE ROAD	GAFFNEY	SC	29341	(864)703-5861	OFFICE@PALMETTOGROUPSC.COM		ASPH PAVING & RESURFACING • CATCH BASIN, MANHOLES, ETC. • CONCRETE PAVING - ROADWAY • CURB OR CURB & GUTTER • ASPHALT ROADWAY PATCHING • BRICK,BLOCK,STONE MASONRY • BUILDINGS - NEW OR REHAB. • CONCRETE WORK - NON-RDWAY •
PALMETTO INFRASTRUCTURE, INC.		3620 PELHAM ROAD	GREENVILLE	SC	29615	(864)879-2166	GCANNIFF@PALMETTOIL.COM	(864)879-2167	BRIDGES - NEW • DRILLED SHAFTS/PILE FOUND. • REBAR - PLACING & TYING • STRUCTURE EXCAVATION • STRUCTURE REMOVAL • CULVERTS - NEW • COFFERDAMS & SHEETPIILING • FENCING • WATERPROOF - SUBSTR/DECK •
PALMETTO SITEWORK SERVICES, LLC		PO BOX 1323	ORANGEBURG	SC	29116	(803)536-3143	GWHITAKER@PSWSLLC.COM	(803)585-0029	GENERAL•
PCL CONSTRUCTION, INC.		1 NORTH DALE MABRY HIGHWAY, SUITE 300	TAMPA	FL	33609	(813)425-1447	JHOLTJE@PCL.COM	(813)961-1575	GENERAL•
PEEK PAVEMENT MARKING, LLC		PO BOX 7337	COLUMBUS	GA	31908	(706)563-5867	RGRAVES@PEEKSAFETY.COM	(706)563-7762	PAVEMENT MARKINGS • RAISED PAVEMENT MARKERS •
PENHALL COMPANY		1801 PENHALL WAY	ANAHEIM	CA	92801	(800)736-4255	SRIVAS@PENHALL.COM		GENERAL•
PERFORMANCE SEALING AND STRIPING, INC.		115 ATLAS BROWN DRIVE	JACKSONVILLE	NC	28540	(910)346-8266	JPATRICK@PERFORMANCESTRIPING.COM	(910)346-9555	CRACK SEALING - ASPHALT RDWY • PAVEMENT MARKINGS • RAISED PAVEMENT MARKERS • AIRPORT RUNWAYS & TAXIWAYS •
PHILLIPS AND JORDAN, INCORPORATED		PO BOX 52050	KNOXVILLE	TN	37950	(865)392-3000	BMILLICAN@PANDJ.COM		GENERAL•
PICKENS CONSTRUCTION, INC.		PO BOX 5135	ANDERSON	SC	29623	(864)224-8999	CANDICE@PICKENSCONSTRUCTION.COM	(864)231-8844	ROADWAY WIDENING • ASPH PAVING & RESURFACING • BASE & SUBBASE WORK • MILLING & GRINDING •
PLATEAU EXCAVATION, INC.		375 LEE INDUSTRIAL BLVD.	AUSTELL	GA	30168	(770)948-2600	BCARROLL@PLATEAUEXCAVATION.COM	(770)948-9393	ROAD CONSTRUCTION - NEW • CLEARING AND GRUBBING • RDWAY EXCAVATION & GRADING • CULVERTS - NEW • HAULING CONSTRUCTION MAT • SOIL STABILIZATION-SITE PREP •
POZZOLANIC CONTRACTING AND SUPPLY COMPANY, INC.	DWBE	PO BOX 14186	KNOXVILLE	TN	37914	(865)225-0090	KBOYD@POZZ.COM	(865)225-0095	FULL DEPTH RECLAMATION • BASE & SUBBASE WORK • SOIL STABILIZATION•
PRECISION 2000, INC.	DBE	2215 LAWSON WAY	ATLANTA	GA	30341	(770)455-6142	CSANCHEZ@PRECISION2K.COM		ROAD CONSTRUCTION - NEW • ROADWAY WIDENING • ASPH PAVING & RESURFACING • CATCH BASIN, MANHOLES, ETC. • CLEARING AND GRUBBING • CONCRETE PAVING - ROADWAY • CONCRETE RDWY JOINT SEALS • CONCRETE SDWLKS & DRIVEWAYS • CURB OR CURB & GUTTER • RDWAY EXCAVATION & ROADWAY LIGHTING • TRAFFIC SIGNALS•TRAFFIC SIGNS - PERMANENT • BRICK,BLOCK,STONE MASONRY • CAMERA & ITMS CABLE • OVERHEAD SIGN STRUCTURES • BUILDINGS - NEW OR REHAB. •
PREMIER CONSTRUCTORS, INC.		PO BOX 3455	WEST COLUMBIA	SC	29171	(803)451-5800	JHILLORD@PREMIERCONSTRUCTORS.NET	(803)796-6381	BRIDGE REPLACEMENT & APPRS. • BRIDGE JOINT INSTALL OR REPAIR • CONCRETE PATCH - STRUCTURES • SHOTCRETING •
PROSHOT CONCRETE, INC.		PO BOX 1636	FLORENCE	AL	35631	(256)764-5941	DONNIE@PROSHOTCONCRETE.COM	(256)764-5946	GENERAL•
PSI OF CONWAY, LLC		PO BOX 861	CONWAY	SC	29528	(843)347-6200	BRYNNEMESIMER@PAVINGSERVICESINC.COM	(843)347-0511	GENERAL•
QUALITY ENTERPRISES USA, INC.		3494 SHEARWATER STREET	NAPLES	FL	34117	(239)435-7200	LGAUDIO@QEUSA.COM	(239)435-7202	GENERAL•

R. H. MOORE COMPANY, INC.		PO BOX 830	MURRELLS INLET	SC	29576	(843)650-2155	BRIANSTARNES@RHMOORECOMPANY.COM	(843)650-0742	GENERAL •
R. L. MORRISON AND SONS, INC.		PO BOX 579	MCCELLENAVILLE	SC	29458	(843)887-3261	ADMIN@RLMORRISONANDSONSINC.COM	(843)887-3208	DRILLED SHAFTS/PILE FOUND. • DREDGING /CHANNEL CLEARING • CONCRETE WORK - NON-RDWY • MARINE DOCKS, FENDERS, ETC. •
R.C. CONSTRUCTION CO., INC.		PO BOX 1998	GREENWOOD	MS	38935	(662)453-2424	LCADE@RCCONST.NET	(662)453-6783	AIRPORT RUNWAYS & TAXIWAYS • BUILDINGS - NEW OR REHAB. • SITE PREP • CONCRETE WORK - NON-RDWY •
R.E. BURNS & SONS CO., INC.		PO BOX 7168	STATESVILLE	NC	28687	(704)924-8646	KATIE@REBURNS.COM		GENERAL •
R.E. GOODSON CONSTRUCTION CO., INC.		457 NORTH SPRINGVILLE ROAD	DARLINGTON	SC	29540	(843)393-2253	JAMES@REGOODSON.COM		BASE & SUBBASE WORK • CLEARING AND GRUBBING • RDWAY EXCAVATION & GRADING • SHOULDER WIDENING • SOIL STABILIZATION•SITE PREP •
RAGNAR BENSON, LLC		833 FEATHERSTONE ROAD	ROCKFORD	IL	61107	(815)654-4700	AARON.STERN@WILLIAMCHARLES.COM		GENERAL •
RAKES BUILDING AND MAINTENANCE CONTRACTORS, LLC DBA BLUTIDE MARINE CONSTRUCTION		3771 BELVEDERE ROAD	JOHNS ISLAND	SC	29455	(843)557-1595	INFO@BLUTIDEMARINE.COM		ROAD CONSTRUCTION - NEW • CLEARING AND GRUBBING • CONCRETE PAVING - ROADWAY • CONCRETE SDWLKS & DRIVEWAYS • RDWAY EXCAVATION & GRADING • ASPHALT ROADWAY PATCHING • BRIDGES - NEW • CONCRETE PATCH - STRUCTURES • REBAR - PLACING & TYING • RETAINING WALLS - C
RAM CONSTRUCTION SERVICES OF MICHIGAN, INC.		13800 ECKLES ROAD	LIVONIA	MI	48150	(734)464-3800	KZIELINSKI@RAMSERVICES.COM	(734)420-1781	WATERPROOF - SUBSTR/DECK • CONCRETE SDWLKS & DRIVEWAYS • PAVEMENT MARKINGS • ROADWAY LIGHTING • TRAFFIC SIGNALS•TRAFFIC SIGNS - PERMANENT • OVERHEAD SIGN STRUCTURES • TRAFFIC CONTROL SERVICES • PUBLIC UTILITIES INSTALL & REPAIR •
RED ELECTRICAL DESIGNS, LLC	DBE	230 S LIVE OAK DR.	MONKS CORNER	SC	29461	(843)761-5115	CRYSTAL@GETREDS.COM		GENERAL •
REEVES CONSTRUCTION COMPANY		250 PLEMMONS RD	DUNCAN	SC	29334	(864)416-0200	EBANTZ@REEVESCC.COM	(864)416-0201	GENERAL •
REEVES YOUNG, LLC		45 PEACHTREE INDUSTRIAL BLVD.	SUGAR HILL	GA	30518	(770)271-1159	JMCCORMACK@REEVESYOUNG.COM	(770)271-5856	GENERAL •
REMAC ASPHALT MAINTENANCE, INC.		PO BOX 9	FREEMAN	VA	23856	(434)634-2111	REMAC@REMACUS.COM	(434)634-0024	CRACK SEALING - ASPHALT RDWY • ASPHALT ROADWAY PATCHING • PAVEMENT MARKINGS • AIRPORT RUNWAYS & TAXIWAYS • PAVING & RESURF - NON HWY •
REYNOLDS FENCE & GUARDRAIL, INC.	DBE	9320 MACHADO DRIVE	INDIAN TRAIL	NC	28079	(704)753-4992	SUSAN@REYNOLDSFENCEANDGUARDRAIL.COM	(704)753-4400	GUARDRAIL-STL BM/CABLE BARR • FENCING • IMPACT ATTEN/CRASH CUSHIONS •
RICHARDSON CONSTRUCTION COMPANY OF COLUMBIA, S.C., INC.		PO BOX 3489	COLUMBIA	SC	29230	(803)786-9741	ESTIMATOR@RICHDIRT.COM	(803)735-1581	GENERAL •
RICKY'S TREE SERVICE, LLC		6081 RACCOON ROAD	MANNING	SC	29102	(803)473-2202	RICKYSTREESERVICE2223@YAHOO.COM		ON CALL SERVICES •
RIFENBURG CONSTRUCTION, INC.		159 BRICK CHURCH RD	TROY	NY	12180	(518)279-3265	TCASEY@RIFENBURG.COM	(518)279-3509	GENERAL •
RMD HOLDINGS, LTD. D/B/A NATIONWIDE CONSTRUCTION GROUP		PO BOX 458	RICHMOND	MI	48062	(586)749-6900	SALES@NATIONWIDECOS.COM	(586)749-6909	GENERAL •
RNF CONSTRUCTION, LLC		2657 MCFARLAND ROAD	YORK	SC	29745	(803)325-9977	DEBBIE@RNFCOS.COM		GENERAL •
ROADSAFE TRAFFIC SYSTEMS, INC.		1718 TWO NOTCH ROAD	LEXINGTON	SC	29073	(803)567-2185	SHAJJAR@ROADSAFETRAFFIC.COM		PAVEMENT MARKINGS • RAISED PAVEMENT MARKERS • TRAFFIC SIGNS - PERMANENT • IMPACT ATTEN/CRASH CUSHIONS • OVERHEAD SIGN STRUCTURES • TRAFFIC CONTROL SERVICES •
ROGERS GROUP, INC.		PO BOX 25250	NASHVILLE	TN	37202	(615)780-5703	WHITNEY.BATES@ROGERSGROUPINC.COM	(615)564-5703	GENERAL •
ROWE, INC. OF BLYTHEWOOD		2074 LYNCHBURG HWY	LYNCHBURG	SC	29080	(803)730-0968	ROWEINC@FTC1-NET		BRIDGES - NEW • DRILLED SHAFTS/PILE FOUND. • REBAR - PLACING & TYING • STRUCTURE EXCAVATION • CULVERTS - NEW • COFFERDAMS & SHEETPIILING • HORIZONTAL JACKING & BORING • PUBLIC UTILITIES INSTALL & REPAIR •
ROYAL BRIDGE, INC.		3601 ALT. 19 SUITE A	PALM HARBOR	FL	34683	(727)934-6042	TOMMY@ROYALBRIDGEINC.COM	(727)234-0942	BRIDGE REPLACEMENT & APPRS. • BRDG REHAB AND/OR WIDENING • BRDG CLEANING AND PAINTING • HAZARDOUS MATERIAL REMOVAL • CONCRETE WORK - NON-RDWY • INDUSTRIAL PAINTING •
RUBY-COLLINS, INC.		4875 MARTIN COURT, SE	SMYRNA	GA	30082	(770)432-2900	SCLINE@RUBY-COLLINS.COM	(770)432-8238	ASPH PAVING & RESURFACING • CATCH BASIN, MANHOLES, ETC. • CLEARING AND GRUBBING • CONCRETE SDWLKS & DRIVEWAYS • CURB OR CURB & GUTTER • ASPHALT ROADWAY PATCHING • DESIGN/BUILD PROJECTS • ON CALL SERVICES • EROSION CONTROL • FENCING • HARDSCAPES/STREETSCAP
S & D INDUSTRIAL PAINTING, INC.		1575 RAINVILLE ROAD	TARPON SPRINGS	FL	34689	(727)937-2080	SDDAMALOS@AOL.COM	(727)942-0076	BRDG CLEANING AND PAINTING •
S & L CONTRACTING, LLC		PO BOX 796	WADESBORO	NC	28170	(704)694-6450	AVRGROUP@WINDSTREAM.NET	(704)694-7401	ROAD CONSTRUCTION - NEW • ROADWAY WIDENING • ASPH PAVING & RESURFACING • BASE & SUBBASE WORK • CATCH BASIN, MANHOLES, ETC. • CLEARING AND GRUBBING • RDWAY EXCAVATION & GRADING • ASPHALT ROADWAY PATCHING • PERM. OR TEMP. VEGETATION • STRUCTURE REMOVAL • CU
S AND S CONSTRUCTION, INC. OF ANDERSON		PO BOX 1865	ANDERSON	SC	29622	(864)332-2998	SANDSINC@BELLSOUTH.NET		ROAD CONSTRUCTION - NEW • ROADWAY WIDENING • BASE & SUBBASE WORK • CATCH BASIN, MANHOLES, ETC. • CLEARING AND GRUBBING • CURB OR CURB & GUTTER • RDWAY EXCAVATION & GRADING • GUARDRAIL-STL BM/CABLE BARR • PERM. OR TEMP. VEGETATION • SHOULDER WIDENING • ERO
S. T. WOOTEN CORPORATION		PO BOX 2408	WILSON	NC	27894	(252)291-5165	JONATHAN@STWCORP.COM	(252)399-0938	GENERAL •
SAFE SHIELD LLC		1135 E. HWY 501	CONWAY	SC	29526	(843)234-0677	ACCOUNTING@SAFESHIELDTRAFFICSOLUTIONS.COM		TRAFFIC SIGNS - PERMANENT • OVERHEAD SIGN STRUCTURES • TRAFFIC CONTROL SERVICES • BRDG REHAB AND/OR WIDENING • BRDG CLEANING AND PAINTING • BRIDGE JACKING • BRIDGE JOINT INSTALL OR REPAIR • CONCRETE PATCH - STRUCTURES • EPOXY/GROUT CRACK INJECT • INDUSTRIAL PAINTING •
SAFFO CONTRACTORS, INC.		PO BOX 7035	WILMINGTON	NC	28406	(910)371-9499	TAYLOR@SAFFOCONTRACTORS.COM	(910)371-9422	GENERAL •
SANDERS BROTHERS CONSTRUCTION COMPANY, INC.		PO BOX 60969	NORTH CHARLESTON	SC	29419	(843)744-4261	CHRIS@SANDERSBROTHERS.COM	(843)554-2095	GENERAL •
SANDHILL A.L.S. CONSTRUCTION, INC.		277 NELSONS COURT	HARDEEVILLE	SC	29927	(843)784-6516	ALS86@HARGRAY.COM	(843)728-2411	CLEARING AND GRUBBING • CONCRETE SDWLKS & DRIVEWAYS • CURB OR CURB & GUTTER • FENCING • LANDSCAPING & PLANTINGS • TRAFFIC CONTROL SERVICES • PAVING & RESURF - NON HWY • PUBLIC UTILITIES INSTALL & REPAIR • ROADWAY LIGHTING •
SANITARY PLUMBING CONTRACTORS, INC.		PO BOX 66	SIMPSONVILLE	SC	29681	(864)862-4452	SWPAUL@SANITARYPLUMBING.NET	(864)862-3147	CATCH BASIN, MANHOLES, ETC. • CONCRETE SDWLKS & DRIVEWAYS • CURB OR CURB & GUTTER • MECH. STABILIZED EARTH WALLS • RETAINING WALLS - CIP • CULVERTS - NEW • CONCRETE WORK - NON-RDWY •
SATTERFIELD CONSTRUCTION COMPANY, INC.		PO BOX 279	GREENWOOD	SC	29648	(864)223-8601	TALEXANDER@SATTERFIELDCONSTRUCTION.ORG	(864)223-3008	ROAD CONSTRUCTION - NEW • ROADWAY WIDENING • ASPH PAVING & RESURFACING • ASPHALT ROADWAY PATCHING • MILLING & GRINDING •
SCODELLER CONSTRUCTION, INC.		51722 GRAND RIVER AVENUE	WIXOM	MI	48393	(248)374-1102	ACCOUNTANT@SCODELLER.COM	(248)374-1109	CONCRETE RDWY JOINT SEALS • CRACK SEALING - ASPHALT RDWY • AIRPORT RUNWAYS & TAXIWAYS • CONCRETE WORK - NON-RDWY •

SCOTT BRIDGE COMPANY, INC.		2641 INTERSTATE DRIVE	OPELIKA	AL	36801	(334)749-5045	TLOWREY@SCOTTBRIDGE.COM	(334)749-3936	CLEARING AND GRUBBING • RDWAY EXCAVATION & GRADING • BRIDGES - NEW • BRDG REHAB AND/OR WIDENING • DRILLED SHAFTS/PILE FOUND. • PILE/DRILLED SHAFT TESTING • REBAR - PLACING & TYING • RETAINING WALLS - CIP • STRUCTURE EXCAVATION • STRUCTURE REMOVAL • COFFE
SCWC ENTERPRISES, INC. D/B/A PHILLIPS PAVING COMPANY		1330 QUACCO ROAD	POOLER	GA	31322	(912)925-4079	DEBORAH.BEASLEY@PHILLIPSPAVINGSAV.COM	(912)927-0732	ROAD CONSTRUCTION - NEW • ROADWAY WIDENING • ASPH PAVING & RESURFACING • CLEARING AND GRUBBING • CONCRETE PAVING - ROADWAY • CONCRETE SDWLKS & DRIVEWAYS • CURB OR CURB & GUTTER • CONC ROADWAY PATCHING • MILLING & GRINDING • PAVEMENT MARKINGS • CULVERTS -
SEACOAST, INC.		765 DUNBAR AVENUE	OLDSMAR	FL	34677	(813)925-3555	LISAV@SEACOASTINC.NET	(813)925-3553	ROAD CONSTRUCTION - NEW • ASPH PAVING & RESURFACING • CONCRETE RDWY JOINT SEALS • BRDG REHAB AND/OR WIDENING • BRIDGE JACKING • BRIDGE JOINT INSTALL OR REPAIR • CONCRETE PATCH - STRUCTURES • DRILLED SHAFTS/PILE FOUND. • REBAR - PLACING & TYING • STRUCTU
SEALAND CONTRACTORS CORP.		PO BOX 350	RUSH	NY	14543	(585)359-9242	JASON.BREE@SEALANDCONTRACTORS.COM	(585)359-4808	GENERAL•
SEED SLINGERS LLC	DWBE	PO BOX 665	AYNOR	SC	29511	(843)358-1870	TONYA@SEEDSLINGERS.COM	(843)358-0984	CLEARING AND GRUBBING • PERM. OR TEMP. VEGETATION • EROSION CONTROL • FENCING • LANDSCAPING & PLANTINGS • MILLED-IN RUMBLE STRIPS • MOWING/VEG CONTROL •
SEMINOLE EQUIPMENT, INC.		204 TARPON INDUSTRIAL DRIVE	TARPON SPRINGS	FL	34689	(727)944-4481	JIMK@SEITARPON.COM	(727)945-0882	BRDG CLEANING AND PAINTING • CLEARING AND GRUBBING • DESIGN/BUILD PROJECTS • REBAR - PLACING & TYING • EROSION CONTROL • HAULING CONSTRUCTION MAT • LANDSCAPING & PLANTINGS • SOIL STABILIZATION+SITE PREP •
SEXTON DESIGN AND DEVELOPMENT, LLC		6 CUSTOM MILL COURT	GREENVILLE	SC	29609	(864)412-7712	JEREMIAH@SEXTONDD.COM		BASE & SUBBASE WORK • CONCRETE PAVING - ROADWAY • CURB OR CURB & GUTTER • CONC ROADWAY PATCHING • RETAINING WALLS - CIP • AIRPORT RUNWAYS & TAXIWAYS • CONCRETE WORK - NON-RDWY •
SHAMROCK CONCRETE CONSTRUCTION, INC.		PO BOX 991428	LOUISVILLE	KY	40269	(502)817-2488	LISASHAMROCK@HOTMAIL.COM		BASE & SUBBASE WORK • ROLLER COMPACTED CONC•SOIL STABILIZATION•
SITE-PREP, INC. OF NC		PO BOX 1609	MONROE	NC	28111	(704)282-8250	LGHENT@SITE-PREP.COM	(866)469-2684	GENERAL•
SJ HAMILL CONSTRUCTION, LLC		2008 CHERRY HILL LANE	CHARLESTON	SC	29405	(843)872-8000	JORDAN@SIHAMILL.COM		MACRO-SURFACING • MICRO-SURFACING •
SKIDABRADER GROUP LLC		5280 CARROLL CANYON ROAD	SAN DIEGO	CA	92121	(800)342-4174	ROSE.PENDLETON@SKIDABRADER.COM	(619)295-0754	ROADWAY WIDENING • TRAFFIC SIGNS - PERMANENT • ASPH SURF TREAT (CHIP SEAL) • CRACK SEALING - ASPHALT RDWY • RDWAY EXCAVATION & GRADING • ASPHALT ROADWAY PATCHING • MICRO-SURFACING • MILLING & GRINDING • PAVEMENT MARKINGS • MILLED-IN RUMBLE STRIPS • SOIL STABILIZATION•
SKYLINE SIGNS LLC		1135 E. HIGHWAY 501	CONWAY	SC	29526	(843)234-0677	ACCOUNTING@SKYLINESSIGNSUSA.COM		CONCRETE SDWLKS & DRIVEWAYS • GUARDRAIL-STL BM/CABLE BARR • ROADWAY LIGHTING • BRIDGE REPLACEMENT & APPRS. • BRIDGE JOINT INSTALL OR REPAIR • DRILLED SHAFTS/PILE FOUND. • PILE/DRILLED SHAFT TESTING • REBAR - PLACING & TYING • AIRPORT RUNWAYS & TAXIWAYS •
SLURRY PAVERS, INC.		3617 NINE MILE ROAD	RICHMOND	VA	23223	(804)264-0707	CDABNEY@SLURRYPAVERS.COM		GENERAL•
SMITH-EMERY LABORATORIES, INC.		781 EAST WASHINGTON BLVD.	LOS ANGELES	CA	90021	(213)749-3411	ALESSARD@SEI.US.COM	(213)741-8420	CLEARING AND GRUBBING • CONCRETE PAVING - ROADWAY • CURB OR CURB & GUTTER • PAVEMENT MARKINGS • FENCING • LANDSCAPING & PLANTINGS • BUILDINGS - NEW OR REHAB. • SITE PREP •
SMITH-ROWE, LLC		639 OLD US 52 SOUTH	MOUNT AIRY	NC	27030	(336)789-8221	JODY@SMITHROWE.COM	(336)789-6807	BRDG CLEANING AND PAINTING •
SOSSAMON CONSTRUCTION COMPANY, INC.		PO BOX 26	GAFFNEY	SC	29342	(864)489-6148	LARRYS@SOSSAMONCONSTRUCTION.COM	(864)489-7570	
SOUTHEAST BRIDGE FL CORP.	DBE	38856 U.S. 19 NORTH	TARPON SPRINGS	FL	34689	(727)940-3401	EVIE@SEBRIDGEFL.COM	(727)940-3431	RAISED PAVEMENT MARKERS • TRAFFIC SIGNS - PERMANENT • TRAFFIC CONTROL SERVICES • BRDG REHAB AND/OR WIDENING • BRDG CLEANING AND PAINTING • BRIDGE JOINT INSTALL OR REPAIR • CONCRETE PATCH - STRUCTURES • INDUSTRIAL PAINTING •
SOUTHERN CONCRETE & CONSTRUCTION, INC.	DBE	PO BOX 1673	ANDERSON	SC	29622	(864)367-0992	KBOULWARE@SOUTHERNCONCRETEDBE.COM	(864)367-0993	ASPH PAVING & RESURFACING • BASE & SUBBASE WORK • CATCH BASIN, MANHOLES, ETC. • CLEARING AND GRUBBING • CURB OR CURB & GUTTER • RDWAY EXCAVATION & GRADING • GUARDRAIL-STL BM/CABLE BARR • PERM. OR TEMP. VEGETATION • EROSION CONTROL • HAULING CONSTRUCTION M
SOUTHERN DISASTER RECOVERY, LLC		109 WHITE OAK ROAD	GREENVILLE	SC	29609	(864)469-9776	JON@GOSDR.COM		BRDG CLEANING AND PAINTING •
SOUTHERN PAVEMENT SOLUTIONS, LLC		115 TIFFANY COURT	LOCUST GROVE	GA	30248	(404)967-4372	INFO@SOUTHERNPAVEMENTSOLUTIONS.COM		CATCH BASIN, MANHOLES, ETC. • CLEARING AND GRUBBING • CONCRETE SDWLKS & DRIVEWAYS • CURB OR CURB & GUTTER • CONC ROADWAY PATCHING • BRIDGES - NEW • RETAINING WALLS - CIP • BRICK,BLOCK,STONE MASONRY • CONCRETE BARRIERS - CIP • LANDSCAPING & PLANTINGS • ENVIRONMENTAL MITIGATION • STORM DEBRIS REMOVE •
SOUTHERN ROAD & BRIDGE, LLC		715 WESLEY AVENUE	TARPON SPRINGS	FL	34689	(727)940-5395	KBEGLAN@SOUTHERNRB.COM	(727)499-7158	RAISED PAVEMENT MARKERS • TRAFFIC SIGNS - PERMANENT • TRAFFIC CONTROL SERVICES • BRDG REHAB AND/OR WIDENING • BRDG CLEANING AND PAINTING • BRIDGE JOINT INSTALL OR REPAIR • CONCRETE PATCH - STRUCTURES • INDUSTRIAL PAINTING •
SOX AND SONS CONSTRUCTION COMPANY, INC.		PO BOX 3875	WEST COLUMBIA	SC	29171	(803)796-9349	SOXANDSONSAP@GMAIL.COM	(803)796-0124	ASPH PAVING & RESURFACING • BASE & SUBBASE WORK • CATCH BASIN, MANHOLES, ETC. • CLEARING AND GRUBBING • CURB OR CURB & GUTTER • RDWAY EXCAVATION & GRADING • GUARDRAIL-STL BM/CABLE BARR • PERM. OR TEMP. VEGETATION • EROSION CONTROL • HAULING CONSTRUCTION M
SPARTAN CONTRACTING, LLC		5959 W. LIBERTY ST	HUBBARD	OH	44425	(330)534-7790	CHOILETTA@AOL.COM	(330)534-7792	BRDG CLEANING AND PAINTING •
STEED CLEARING GRADING & PAVING LLC		102 BATES HILL ROAD	JACKSON	SC	29831	(706)941-2935	SAM@STEEDPAVING.COM		ASPH PAVING & RESURFACING • CONCRETE PAVING - ROADWAY • CONCRETE RDWY JOINT SEALS • CONCRETE SDWLKS & DRIVEWAYS • MILLING & GRINDING • PAVING & RESURF - NON HWY •
STEMBRIDGE CUSTOM METALS, INC.	DBE	10720 WOODRUFF ROAD	FAIRBURN	GA	30213	(770)969-8139	BSTEMSR@ATT.NET		GUARDRAIL-STL BM/CABLE BARR • TRAFFIC CONTROL SERVICES •
STRAIGHT LINE, INC.	DWBE	1559 BETSY LANE	GALIVANTS FERRY	SC	29544	(843)602-1804	STRAIGHTLINE@SCCOAST.NET	(843)358-1972	PAVEMENT MARKINGS • RAISED PAVEMENT MARKERS • MILLED-IN RUMBLE STRIPS •
STRANGE BROS. GRADING CO., INC.		PO BOX 7	TAYLORS	SC	29687	(864)244-2515	MIKE@STRANGEBROS.COM	(864)244-1474	GENERAL•
STRAWSER CONSTRUCTION, INC.		1392 DUBLIN ROAD	COLUMBUS	OH	43215	(614)276-5501	TONYAM@STRAWSERINC.COM	(614)276-0570	GENERAL•
STRUCTURAL PRESERVATION SYSTEMS, LLC		10150 OLD COLUMBIA RD	COLUMBIA	MD	21046	(410)850-7000	MMONZONCUEVAS@STRUCTURALGROUP.COM		ENVIRONMENTAL MITIGATION • BUILDINGS - NEW OR REHAB. • CONCRETE WORK - NON-RDWY • BRIDGE REPLACEMENT & APPRS. • BRDG REHAB AND/OR WIDENING • BRIDGE - EMERGENCY REPAIR • BRIDGE JOINT INSTALL OR REPAIR • BRICK,BLOCK,STONE MASONRY • BUILDINGS - NEW OR REHAB. • CONCRETE WORK - NON-RDWY •
STRUCTURAL TECHNOLOGIES, LLC		10150 OLD COLUMBIA ROAD	COLUMBIA	MD	21046	(410)850-7000	MMONZONCUEVAS@STRUCTURALTEC.COM	(410)850-4111	EXPOXY/GROUT CRACK INJECT • EROSION CONTROL • AIRPORT RUNWAYS & TAXIWAYS • SITE PREP • CONCRETE WORK - NON-RDWY •
SUMMERS CONCRETE CONTRACTING, INC.		5538 COPPAGE ROAD	HAHIRA	GA	31632	(229)794-1023	SUMMERSOFFICE@WINDSTREAM.NET	(229)794-1218	ROAD CONSTRUCTION - NEW • ROADWAY WIDENING • BASE & SUBBASE WORK • CONCRETE PAVING - ROADWAY • RDWAY EXCAVATION & GRADING • ASPHALT ROADWAY PATCHING • SHOULDER WIDENING • DESIGN/BUILD PROJECTS • BRIDGES - NEW • RETAINING WALLS - CIP • STRUCTURE EXCAVATION
SUPERIOR CONSTRUCTION COMPANY SOUTHEAST, LLC		7072 BUSINESS PARK BLVD. N.	JACKSONVILLE	FL	32256	(904)292-4240	SEE@SUPERIORCONSTRUCTION.COM	(904)292-2682	ASPH SURF TREAT (CHIP SEAL) • PAVEMENT MARKINGS • MILLED-IN RUMBLE STRIPS • TRAFFIC CONTROL SERVICES •
SURFACE PREPARATION TECHNOLOGIES, LLC		PO BOX 834	NEW KINGSTOWN	PA	17072	(717)697-1450	PREQUAL@SURFPREPTECH.COM	(717)697-0813	

SWANK CONSTRUCTION COMPANY, LLC		632 HUNT VALLEY CIRCLE	NEW KENSINGTON	PA	15068	(724)335-6000	LISA@SWANKCO.COM	(724)335-3834	ROADWAY WIDENING • BASE & SUBBASE WORK • CATCH BASIN, MANHOLES, ETC. • CLEARING AND GRUBBING • CONCRETE PAVING - ROADWAY • CONCRETE RDWY JOINT SEALS • CONCRETE SDWLKS & DRIVEWAYS • CURB OR CURB & GUTTER • MILLING & GRINDING • BRIDGES - NEW • BRIDGE REPLAC
T.F.R. ENTERPRISES, INC.		601 LEANDER DRIVE	LEANDER	TX	78641	(512)260-3322	TIFFANY@TFRINC.COM	(512)528-1942	STORM DEBRIS REMOVE •
TCO CONSTRUCTION INC.		55 M & N RD	SUMTER	SC	29153	(803)495-4420	LALS@TCOCONSTRUCTION.COM	(803)495-4430	GENERAL•
TENMILE CREEK EXCAVATING, LLC		407 E. FORT STREET, SUITE 407	DETROIT	MI	48226	(313)963-4263	DAVERYDZINSKI@WECANDIGIT.COM	(313)964-8835	FULL DEPTH RECLAMATION • MILLING & GRINDING • SOIL STABILIZATION •
THALLE CONSTRUCTION CO., INC.		900 NC HIGHWAY 86 NORTH	HILLSBOROUGH	NC	27278	(919)245-1490	PANDREW@THALLE.COM	(919)241-1659	GENERAL•
THE AVRETT COMPANY, INC.		1547 GORDON HIGHWAY	AUGUSTA	GA	30906	(706)796-0200	MAGGIE@THEAVRETTCOMPANY.COM	(706)792-0654	CATCH BASIN, MANHOLES, ETC. • CAMERA & ITMS CABLE • EXPOXY/GROUT CRACK INJECT • SOIL STABILIZATION•TRAFFIC CONTROL SERVICES • BUILDINGS - NEW OR REHAB. • SITE PREP • PUBLIC UTILITIES INSTALL & REPAIR • STORM DEBRIS REMOVE •
THE EROSION COMPANY, LLC		PO BOX 100100	ATLANTA	GA	30348	(678)990-0207	KCHASTAIN@TECOMPANIES.COM		EROSION CONTROL • LANDSCAPING & PLANTINGS •
THE L. C. WHITFORD COMPANY, INC.		3765 FRANCIS CIRCLE	ALPHARETTA	GA	30004	(770)346-0610	KARLYOUNG@LCWGA.COM	(770)346-0525	BRIDGES - NEW • BRIDGE REPLACEMENT & APPRS. • BRDG REHAB AND/OR WIDENING • BRIDGE JACKING • BRIDGE JOINT INSTALL OR REPAIR • DRILLED SHAFTS/PILE FOUND. • NON-AC OVERLAY - BR. DECKS • TEMPORARY BRIDGES • CONCRETE BARRIERS - CIP • OVERHEAD SIGN STRUCTURES
THE LANE CONSTRUCTION CORPORATION		6125 TYVOLA CENTRE DRIVE	CHARLOTTE	NC	28217	(203)235-3351	SCRPEQUAL@LANECONSTRUCT.COM	(203)651-1864	GENERAL•
THE MIDDLESEX CORPORATION		ONE SPECTACLE POND ROAD	LITTLETON	MA	01460	(978)742-4400	DSOCCI@MIDDLESEXCO.COM	(978)742-4434	GENERAL•
THE MILLER GROUP, INC.		1715 NOLAN COURT	MORROW	GA	30260	(770)968-9100	MARTIE.OKELLEY@MILLERGROUP.CA	(770)968-0002	ROADWAY WIDENING • ASPH SURF TREAT (CHIP SEAL) • FULL DEPTH RECLAMATION • BASE & SUBBASE WORK • RDWAY EXCAVATION & GRADING • MILLING & GRINDING • MILLED-IN RUMBLE STRIPS • SOIL STABILIZATION•
THE SCRUGGS COMPANY		PO BOX 2065	VALDOSTA	GA	31604	(229)242-2388	RAKINS@SCRUGGSCOMPANY.COM	(229)242-7109	GENERAL•
THE SHARON COMPANY, INC.	DBE	PO BOX 1366	LEXINGTON	SC	29071	(803)957-3101	SHARON@SHARONCOMPANY.COM	(803)951-0496	GUARDRAIL-STL BM/CABLE BARR •
THE TRUESDELL CORPORATION		1310 W. 23RD STREET	TEMPE	AZ	85282	(602)437-1711	NMACKOWIAK@TRUESDELLCORP.COM	(602)437-1821	CONC ROADWAY PATCHING • BRDG REHAB AND/OR WIDENING • BRIDGE JOINT INSTALL OR REPAIR • CONCRETE PATCH - STRUCTURES • NON-AC OVERLAY - BR. DECKS • STRUCTURE REMOVAL •
THORN CREEK MARKERS LLC		2834 FISHER ROAD	COLUMBUS	OH	43221	(614)279-2544	JNOTT@WLMARKERS.COM		PAVEMENT MARKINGS • RAISED PAVEMENT MARKERS • TRAFFIC CONTROL SERVICES •
THRELKO, INCORPORATED		PO BOX 298	NINETY SIX	SC	29666	(864)223-5783	THRELKO@YAHOO.COM	(864)388-0802	BASE & SUBBASE WORK • CATCH BASIN, MANHOLES, ETC. • CLEARING AND GRUBBING • CURB OR CURB & GUTTER • RDWAY EXCAVATION & GRADING • PERM. OR TEMP. VEGETATION • SHOULDER WIDENING • STRUCTURE EXCAVATION • EROSION CONTROL •
THRIFT BROTHERS, INC.		PO BOX 1293	SENECA	SC	29679	(864)882-3931	MTHYDRICK@GMAIL.COM	(864)882-7607	ROAD CONSTRUCTION - NEW • BASE & SUBBASE WORK • CATCH BASIN, MANHOLES, ETC. • CLEARING AND GRUBBING • RDWAY EXCAVATION & GRADING • EROSION CONTROL • SITE PREP • PAVING & RESURF - NON HWY •
THRIFT DEVELOPMENT CORPORATION		PO BOX 2125	SENECA	SC	29679	(864)882-4582	RMILLER@THRIFTDEV.COM	(864)882-0808	GENERAL•
TIC-THE INDUSTRIAL COMPANY		1550 MIKE FAHEY STREET	OMAHA	NE	68102	(402)342-2052	SAOIRSE.COMSTOCK@KIEWIT.COM	(402)536-3607	GENERAL•
TITAN INDUSTRIAL SERVICES, INC.		4054 NORTH POINT ROAD	BALTIMORE	MD	21222	(410)477-1857	ACCOUNTING@TITANINDUST.COM	(410)477-1859	BRDG REHAB AND/OR WIDENING • BRDG CLEANING AND PAINTING • CONCRETE PATCH - STRUCTURES • NON-AC OVERLAY - BR. DECKS • CULVERTS- NEW • WATERPROOF - SUBSTR/DECK • CLEARING AND GRUBBING • CONCRETE SDWLKS & DRIVEWAYS • CURB OR CURB & GUTTER • PAVEMENT MARKINGS • PERM. OR TEMP. VEGETATION • DESIGN/BUILD PROJECTS • REBAR - PLACING & TYING • RETAINING WALLS - CIP • STRUCTURE EXCAVATION • DREDGING /CHANNEL CLEARING • ON
TOLLESON LIMITED COMPANY	DBE	305-A STONERIDGE DRIVE	COLUMBIA	SC	29210	(803)783-9001	CSACK@TOLLESONLTD.COM		ROADWAY LIGHTING • TRAFFIC SIGNALS•TRAFFIC SIGNS - PERMANENT • DESIGN/BUILD PROJECTS • CAMERA & ITMS CABLE •
TRAFFIC CONTROL DEVICES, LLC		PO BOX 150418	ALTAMONTE SPRINGS	FL	32715	(407)869-5300	A.GALBREATH@TCD-USA.COM	(407)869-9095	
TRAYLOR BROS., INC.		835 N. CONGRESS AVENUE	EVANSVILLE	IN	47715	(812)477-1542	TBIADMIN@TRAYLOR.COM	(812)474-3223	GENERAL•
TRIAD ENGINEERING & CONTRACTING COMPANY		9715 CLINTON ROAD	BROOKLYN	OH	44144	(440)786-1000	DLIPINSKI@TRIAD-ENGINEERING.COM	(216)651-0754	GENERAL•
TRIANGLE GRADING & PAVING, INC.		PO DRAWER 2570	BURLINGTON	NC	27216	(336)584-1745	ACORBETT@TGANDP.COM	(336)584-0145	GENERAL•
TRULL CONTRACTING, LLC		PO BOX 379	MIDLAND	NC	28107	(704)785-9465	JTRULL@TRULLCONTRACTING.COM	(704)785-9469	GENERAL•
TRULLUCK CONSTRUCTION, INC.		PO BOX 32219	CHARLESTON	SC	29417	(843)766-5571	BORDY@TRULLUCKCONST.COM	(843)766-5574	GENERAL•
TURN-KEY TUNNELING, INC.		1247 STIMMEL ROAD	COLUMBUS	OH	43223	(614)275-4832	MONICA@TUNNELIT.NET	(614)275-4834	GENERAL•
UNITED INFRASTRUCTURE GROUP, INC.		PO BOX 268	GREAT FALLS	SC	29055	(803)581-6000	JAMES.TRIPLETT@UIG.NET		ROAD CONSTRUCTION - NEW • ROADWAY WIDENING • BASE & SUBBASE WORK • CATCH BASIN, MANHOLES, ETC. • CLEARING AND GRUBBING • RDWAY EXCAVATION & GRADING • DESIGN/BUILD PROJECTS • BRIDGES - NEW • BRIDGE REPLACEMENT & APPRS. • DRILLED SHAFTS/PILE FOUND. • PILE/D
UNITED INFRASTRUCTURE GROUP-REEVES CONSTRUCTION COMPANY JV		5562 PENDERGRASS BLVD.	GREAT FALLS	SC	29055	(704)201-8935	MIKE.GREY@UIG.NET		GENERAL•
UNIVERSAL CIVIL CONSTRUCTION, LLC		1721 PRICE HOUSE ROAD	ROEBUCK	SC	29376	(864)565-8581	MCHRISTIE@UNIVERSALCIVILCONSTRUCTION.COM		BASE & SUBBASE WORK • CATCH BASIN, MANHOLES, ETC. • RDWAY EXCAVATION & GRADING • EROSION CONTROL • SITE PREP •
US LBM Operating Co. 2009 LLC DBA MANER BUILDERS SUPPLY		PO BOX 40516	NORTH CHARLESTON	SC	29418	(843)552-0242	CJOHNSON@MANER.COM		FENCING •
USA STRUCTURAL STEEL & FOUNDATIONS, INC.		6448 PARKLAND DRIVE	SARASOTA	FL	34243	(941)955-7106	KATIE.KINNETZ@USA-GROUPS.COM	(941)308-3103	DESIGN/BUILD PROJECTS • BUILDINGS - NEW OR REHAB. •
UTILITY LINES CONSTRUCTION SERVICES, LLC		212 UNIONVILLE-INDIAN TRAIL RD	INDIAN TRAIL	NC	28079	(704)684-0119	PCREED@ASPLUNDH.COM	(704)684-0173	CAMERA & ITMS CABLE • PUBLIC UTILITIES INSTALL & REPAIR •
UTILITY SERVICE CONTRACTORS, INC.		777 OLD CLEMSON ROAD	COLUMBIA	SC	29229	(803)750-2472	BEDWARDS@UTILITYSC.COM	(803)788-6411	CAMERA & ITMS CABLE • EROSION CONTROL • HORIZONTAL JACKING & BORING • SOIL STABILIZATION•TRAFFIC CONTROL SERVICES • CONCRETE WORK - NON-RDWAY • PAVING & RESURF - NON HWY • PUBLIC UTILITIES INSTALL & REPAIR •

VECELLIO & GROGAN, INC.	PO BOX 2438	BECKLEY	WV	25802	(304)252-6575	MICHELE.WIKEL@VECELLIOGROGAN.COM	(304)252-4131	GENERAL • ROAD CONSTRUCTION - NEW • ASPH PAVING & RESURFACING • FULL DEPTH RECLAMATION • BASE & SUBBASE WORK • CLEARING AND GRUBBING • CURB OR CURB & GUTTER • ASPHALT ROADWAY PATCHING • MILLING & GRINDING • PAVEMENT MARKINGS • TRAFFIC SIGNS - PERMANENT • SHOULDER W
VENESKY ASPHALT PAVING AND GRADING, LLC	PO BOX 422	EASLEY	SC	29641	(864)859-8594	VENESKYASPHALT@AOL.COM	(864)855-1533	COFFERDAMS & SHEETPIILING • EXPOXY/GROUT CRACK INJECT • PUBLIC UTILITIES INSTALL & REPAIR • SHOTCRETING •
VORTEX SERVICES, LLC	18150 IMPERIAL VALLEY DRIVE	HOUSTON	TX	77060	(713)750-9081	SLARSON@VORTEXCOMPANIES.COM	(833)247-7943	
VSL ELECTRICAL, SIGNING, LIGHTING LLC	11116 INDUSTRIAL ROAD	MANASSAS	VA	20109	(703)225-7815	VSL-PREQUAL@LANECONSTRUCT.COM		GENERAL • CRACK SEALING - ASPHALT RDWY • PAVEMENT MARKINGS • RAISED PAVEMENT MARKERS • MILLED IN RUMBLE STRIPS • TRAFFIC CONTROL SERVICES •
W L MARKERS, INC.	2834 FISHER ROAD	COLUMBUS	OH	43204	(614)279-2544	JNOTT@WLMARKERS.COM	(614)279-4221	
W.C. ENGLISH, INCORPORATED	PO BOX P-7000	LYNCHBURG	VA	24505	(434)845-0301	JDALTON@ENGLISHCONST.COM	(434)845-0306	GENERAL • ROAD CONSTRUCTION - NEW • BASE & SUBBASE WORK • TRAFFIC SIGNALS • TRAFFIC SIGNS - PERMANENT • OVERHEAD SIGN STRUCTURES • TRAFFIC CONTROL SERVICES •
W.M. ROEBUCK, INCORPORATED	4850 FISH HATCHERY ROAD	LEXINGTON	SC	29073	(803)755-6010	WMROEBUCKINC@GMAIL.COM		
WALKER & WHITESIDE, INC.	PO BOX 5777	GREENVILLE	SC	29606	(864)242-4820	BBETSILL@WALKERWHITESIDE.COM	(864)242-4828	ROADWAY LIGHTING • AIRPORT RUNWAYS & TAXIWAYS • BUILDINGS - NEW OR REHAB. •
WALKER BROTHERS, INC.	PO BOX 1045	LEXINGTON	SC	29071	(803)359-2839	MCKELLAR@WALKERSIGNALS.COM	(803)359-6484	TRAFFIC SIGNALS •
WATERTIGHT SYSTEMS, INC.	PO BOX 1625	LEXINGTON	SC	29071	(803)796-9695	MARK@WATERTIGHTSYSTEMS.COM	(803)926-1976	BRICK, BLOCK, STONE MASONRY • WATERPROOF - SUBSTR/DECK • BUILDINGS - NEW OR REHAB. • CONCRETE WORK - NON-RDWY • PAVING & RESURF - NON HWY •
WATSON ELECTRICAL CONSTRUCTION CO. LLC	1500 CHARLESTON STREET	WILSON	NC	27893	(252)237-7511	RROUSE@WATSONELEC.COM	(252)243-1805	ROADWAY LIGHTING • TRAFFIC SIGNALS • DESIGN/BUILD PROJECTS • CAMERA & ITMS CABLE • ON CALL SERVICES •
WEBBER, LLC	1725 HUGHES LANDING BLVD., SUITE 1200	THE WOODLANDS	TX	77380	(281)907-8600	ABENAGES@WWEBBER.COM	(281)449-6658	GENERAL •
WEST CONTRACTING, INC.	PO BOX 310	MARBLE	NC	28905	(828)837-2280	CHERYLMKELLEY@FRONTIER.COM	(828)837-3364	CLEARING AND GRUBBING • SITE PREP • BASE & SUBBASE WORK • CATCH BASIN, MANHOLES, ETC. • CLEARING AND GRUBBING • CONCRETE RDWY JOINT SEALS • CONCRETE SDWLKS & DRIVEWAYS • CURB OR CURB & GUTTER • RDWY EXCAVATION & GRADING • MACRO-SURFACING • PERM. OR TEMP. VEGETATION • RETAINING WALLS - CIP
WHAM BROS. CONSTRUCTION CO., INC.	PO BOX 4197	ANDERSON	SC	29622	(864)224-3305	CHARLIEWHAM1@GMAIL.COM		
WILDWOOD CONTRACTORS, INC.	1706 HAMPTON ST.	WALTERBORO	SC	29488	(843)549-2575	WILDWOODWWL@LOWCOUNTRY.COM	(843)549-2329	ROAD CONSTRUCTION - NEW • ASPH PAVING & RESURFACING • FULL DEPTH RECLAMATION • BASE & SUBBASE WORK • CATCH BASIN, MANHOLES, ETC. • CLEARING AND GRUBBING • CONCRETE SDWLKS & DRIVEWAYS • CURB OR CURB & GUTTER • ASPHALT ROADWAY PATCHING • CONC ROADWAY PATCHI
WILLIAMS INFRASTRUCTURE, LLC	PO BOX 2046	LEXINGTON	SC	29071	(803)814-3753	ASHLIE@WILLIAMSINFRA.COM		GENERAL •
WRIGHT BROTHERS CONSTRUCTION COMPANY, INC.	PO BOX 437	CHARLESTON	TN	37310	(423)336-2261	IMANNING@WBCCI.COM	(423)336-2079	GENERAL •
ZACHRY CONSTRUCTION CORPORATION	PO BOX 33240	SAN ANTONIO	TX	78265	(210)871-2700	BRYAN.GOLLA@ZACHRYCORP.COM	(210)871-6910	GENERAL •

If self-performing 100% sign below and return this page with your bid/proposal.

I hereby certify my company's intent to perform one hundred percent (100%) of the work required for:

Project Name: Spanish Moss Trail Port Royal Extension

Bid/Proposal Number: IFB# 082424E

By signing this affidavit, I further certify that my company has the capability to perform and will perform all elements of the work on the project referenced above with my company's employees.

I further agree to provide additional information or documentation requested by Beaufort County in support of the above statement.

If a need to subcontract all and/or some of my company's work on this project arises, I will notify the Beaufort County Compliance Office in writing within three (3) business days.

JS Construction Services, Inc.
Name of Company

John Lopat
Authorized Representative Name

[Signature]
Signature

President
Title

8/24/2023
Date

State of South Carolina County of Beaufort

Subscribed and sworn to before me this 24th day of August 2024

Notary Public [Signature] My Commission Expires: 11-10-2025

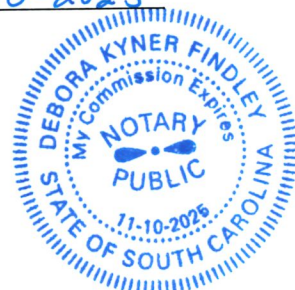



County Council of Beaufort County
Procurement Services Department
102 Industrial Village Road, Bldg 2
Beaufort, SC 29901-1228

August 31, 2023

Re: Spanish Moss Trail Port Royal Extension IFB 082423

Attn: Victoria Moyer

In response to your letter dated August 25, 2023, JS Construction Services, Inc. intends to use Carolina Traffic Controls Inc. for the signalization work and J. Russell Bishop for the temporary and permanent striping on the above reference project.

Carolina Traffic Controls Inc. is a duly licensed and prequalified SCDOT Contractor. J. Russell Bishop is not but there is no specific licensing for line striping contractors.

All other work will be self-performed, JS Construction Services, Inc. SC License # is 105742.

Thank you,

John Lopat, President
JS Construction Services, Inc.



BEAUFORT COUNTY COUNCIL AGENDA ITEM SUMMARY

ITEM TITLE:
Recommend Approval of Contract Award to Beaufort Construction of SC, LLC for IFB #052523 Port Royal Public Library Construction Services (\$480,000.00)
MEETING NAME AND DATE:
Public Facilities and Safety Committee – September 25, 2023
PRESENTER INFORMATION:
Eric Larson, PE, Director, Capital Projects (5 mins)
ITEM BACKGROUND:
Beaufort County requested bids for the new Port Royal Branch Library on 8/25/23. One bid was received from Beaufort Construction of SC, LLC with a cost of \$445,307.00. Staff and the design consultant, McMillan Pazdan Smith, have reviewed the detailed bid submittal and found the prices to be fair and reasonable.
PROJECT / ITEM NARRATIVE:
An existing approximately 3,200 sf building on Paris Avenue will be remodeled into a new Branch Library. The total funds requested are the bid amount (plus a contingency) from the remaining budget (\$445,307.00 + \$34,693 = \$480,000) Purchasing has not submitted a draft contract to Legal. This will occur after contract award.
FISCAL IMPACT:
Funding comes from Library Impact Fees, 26030011-54420. Current account balance is \$606,400.
STAFF RECOMMENDATIONS TO COUNCIL:
Staff recommends approval of contract to Beaufort Construction of SC, LLC award of IFB #052523 in the amount of \$445,307.00 with a \$34,693 contingency fund for a total of \$480,000.00
OPTIONS FOR COUNCIL MOTION:
Motion to approve/deny recommendation of award Beaufort Construction of SC, LLC for IFB #052523 Port Royal Library Construction. <i>Next Step: Move forward to County Council to award Beaufort Construction of SC, LLC for IFB #052523 Port Royal Library Construction.</i>

PRELIMINARY BID TABULATION

PURCHASING DEPARTMENT

Item 2.



Project Name:	Port Royal Library Renovations
Project Number:	IFB 052523
Project Budget:	
Bid Opening Date:	25-Aug-23
Time:	3:00:00 PM
Location:	Beaufort County
Bid Administrator:	Dave Thomas
Bid Recorder:	Victoria Moyer

The following bids were received for the above referenced project:

BIDDER	BID FORM	ALL ADDENDA	Bid Bond	SCH OF VALUES	SMBE Docs	Sub Listing	Grand Total Price
Beaufort Construction	X	X	X	X	X	X	\$ 445,307.00

Beaufort County posts PRELIMINARY bid tabulation information within 2 business days of the advertised bid opening. Information on the PRELIMINARY bid tabulation is posted as it was read during the bid opening. Beaufort County makes no guarantees as to the accuracy of any information on the PRELIMINARY tabulation. The bid results indicated here do not necessarily represent the final compliance review by Beaufort County and are subject to change. After the review, the final award will be made by Beaufort County Council and a certified bid tab will be posted online.

Bid Administrator Signature

Victoria Moyer

Bid Recorder

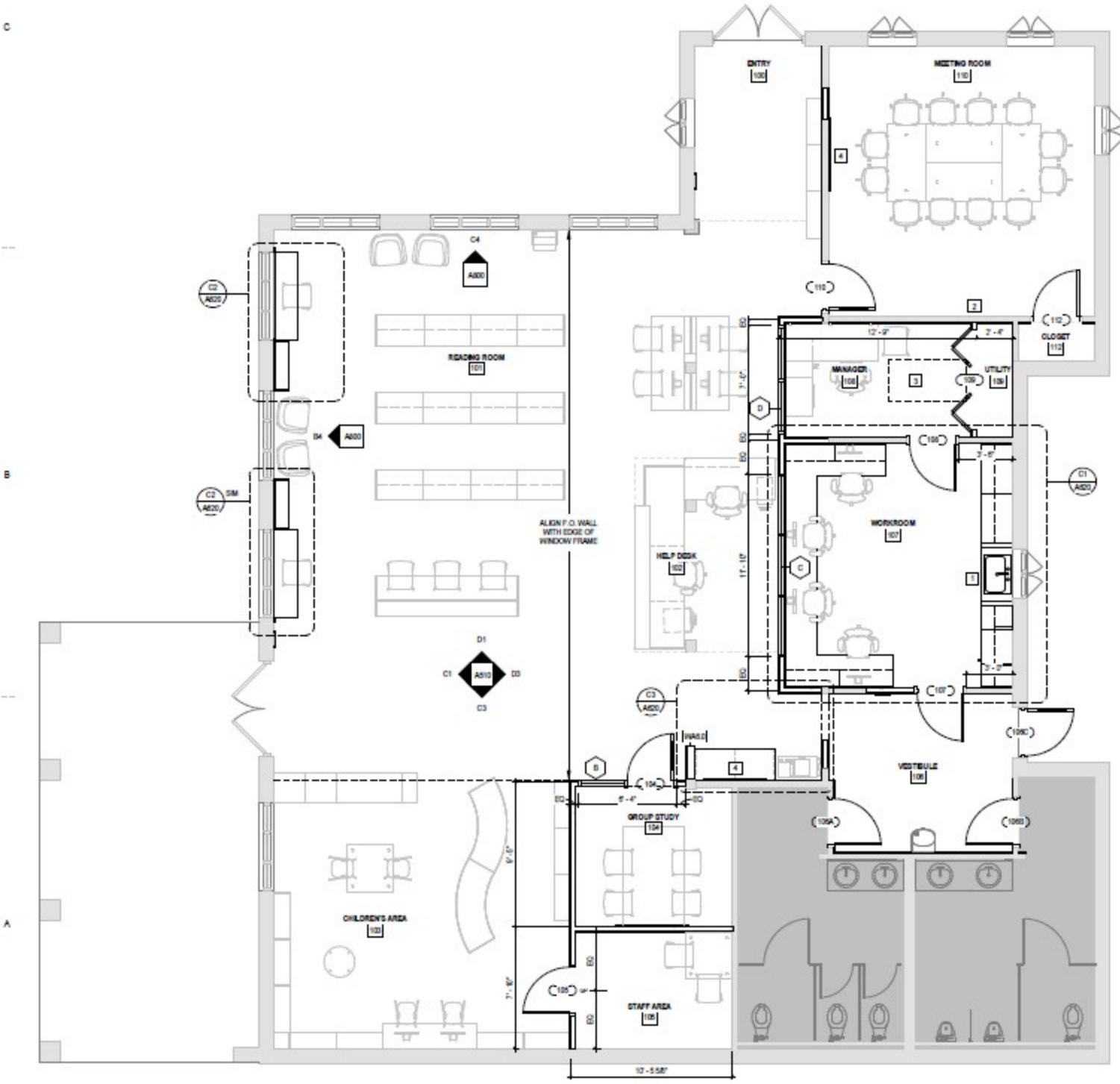

A1 FLOOR PLAN
A110 1/4" = 1'-0"





BEAUFORT COUNTY COUNCIL AGENDA ITEM SUMMARY

ITEM TITLE:
Request to purchase 2023 Peterbilt 547 Vacuum Truck (\$570,000) Sourcewell # 101221-GPV for replacement.
MEETING NAME AND DATE:
Public Facilities Committee Meeting – September 25, 2023
PRESENTER INFORMATION:
Jared Fralix, P.E., Assistant County Administrator, Infrastructure Neil J. Desai, P.E., Public Works Director (5 Minutes)
ITEM BACKGROUND:
The existing piece of equipment continues to experience frequent downtime and constantly incurs excessive repair costs. The asset has been evaluated by the Fleet Manager and is recommended for replacement.
PROJECT / ITEM NARRATIVE:
Purchase of 2023 Peterbilt 548 (6x4) 370HP, 62,000 LB GVWR Auto, Vacuum Truck. Personnel with the Stormwater Infrastructure Section will utilize this equipment to investigate and maintain the County's drainage system.
FISCAL IMPACT:
A quote has been provided from AQUP from Sourcewell #101221-GPV in the amount of \$570,000. The funding source for this item was approved in the FY2024 budget for Public Works under "Stormwater Capital Fund with a balance of \$644,000" account number 50250011-54000.
STAFF RECOMMENDATIONS TO COUNCIL:
The Public Works Director recommend approving the purchase of the 2023 Peterbilt 548 Vacuum Truck to replace asset # 41774 – 2018 VacCon Vacuum Truck (42,587 miles).
OPTIONS FOR COUNCIL MOTION:
Motion to either accept/deny the recommendation to approve the purchase of the 2023 Peterbilt 548 Vacuum Truck. <i>Next Steps - A Majority Vote for Acceptance by Committee would move item forward to final acceptance by full County Council vote.</i>

.....**NEW VEHICLE / EQUIPMENT REQUEST**

Purchases valued at over \$10,000 are considered a capital asset and, therefore, must be accounted for in particular ways. If you would like to request a new vehicle or heavy equipment valued at \$10,000 or more in your upcoming budget, you must coordinate with the County's **Fleet Manager**. Follow the steps and instructions below for filling out this form and how to submit this as part of your departmental budget.

1. Check with the County **Fleet Manager** if you need assistance with the type of vehicle or heavy equipment that your department may need. They will also provide the most up to date costs for each item. This will ensure the proper budgeted amounts are reflected in your budget request submission.
2. Use the New Vehicle/Heavy Equipment Request Form as part of this submission to the Finance Department. Please fill in all information on the form, giving complete justification as to why you need a new vehicle or piece of heavy equipment. Be sure to indicate whether this is a request for replacement of an existing vehicle/heavy equipment item or a new request.
3. If your department is requesting a vehicle, please be sure that you reference the Five-Year Replacement Plan(s).
4. Please submit the completed form along with your other budget requests to the Finance Department. This request should be entered as part of your capital budget.

Department: Stormwater Infrastructure

Prepared By: Pamela Cobb

Department Number: 50250011

Phone Number: 843-255-2721

Type of Vehicle or Heavy Equipment needed: Vacuum Truck

Approximate Cost of New Vehicle/Heavy Equipment: \$570,000

What will the new vehicle/heavy equipment be used for and who will be using it?

Personnel with the Stormwater Infrastructure Section will utilize this equipment in investigating and maintaining the County's

This Vehicle/Heavy Equipment is: New Replacement Asset

If a replacement asset, what asset are you replacing (please include the asset number and/or VIN)?

41774 - 2018 VacCon Vacuum Truck

Why are you replacing this asset?

This equipment continues to experience frequent downtime and incur excessive repair costs. The equipment has been evaluated by the Fleet Manager and recommended for replacement.

How many miles or hours are on the vehicle or equipment you are replacing? N/A

Please list below any other items/costs associated with the purchase and/or outfitting of this vehicle/ equipment:
Garage; Insurance; Registration and Tags;

Signature: Neil J. Desai, P.E. Digitally signed by Neil J. Desai, P.E.
Date: 2023.09.18 13:57:27 -04'00'

Date: September 15, 2023

Title: Public Works Director

RE: PURCHASE OF VEHICLES

This purchase Letter of Intent (the "LOI") represents the basic terms agreed upon by Beaufort County and GapVax Incorporated. Following your acceptance of the terms established herein, Beaufort County is prepared to present the terms to the Beaufort County Council for approval as required by South Carolina Law. After this LOI has been made and Beaufort County Council has approved the purchase, then a formal agreement may be constructed to the benefit of the Parties involved.

- 1. **The Buyer:** Beaufort County, South Carolina, a political subdivision of the State of South Carolina (the "County").
- 2. **The Seller:** GapVax Incorporated (the "Seller").
- 3. **The Product or Service:** The County intends to purchase the following vehicle(s) based on the referenced Seller's Quote, hereinafter the "Product":

Vehicle Description	Seller Quote No. <i>22458</i>	Purchase Price
2023 Peterbilt 548 (6x4) 370 HP, 62,000 LB GVWR Auto, Vacuum Truck, White in Color	Quote ID 23xxx , Sourcewell Contract No. 101221-GPV prepared by AQUP. See the attached quote.	Per Unite Price: \$565,049.88. This includes delivery and SC taxes.

- 4. **Purchase Price:** The Purchase Price for the Product is stated above and is further described in Exhibit A, attached hereto and incorporated herein by reference.
- 5. **Payment:** The County will make payment in full by way of a check following delivery and acceptance of the Product.
- 6. **Contingency.** The Seller understands and acknowledges that pursuant to South Carolina law, the County is required to receive approval from Beaufort County Council for the purchase of the Product. If funding is not approved and provided by Beaufort County Council, then this LOI, and any other written or verbal agreements, shall terminate automatically. The County will provide written notice to Seller of such termination, but no written notice is required for the termination.
- 7. **Binding Effect:** This LOI shall be considered non-binding. Therefore, the Parties acknowledge that this LOI is not enforceable by any Party. The terms outlined herein are solely for the purposes of reaching a final agreement in the future, of which, Buyer and Seller are not bound.
- 8. **Future Agreement:** Should this LOI not be cancelled, the County will issue a purchase order at a later date but no later than October 2, 2023, confirming the County's order of the referenced vehicle.
- 9. **Currency:** All mentions of money or the usage of the "\$" icon shall be known as referring to the US Dollar.
- 10. **Governing Law:** This LOI shall be governed under the laws by the State of South Carolina.

Please evidence your acceptance of the terms contained herein and your agreement to move forward in good faith to negotiate a final agreement embodying these terms and such other terms and conditions as are mutually agreed upon.

COUNTY

County's Signature David L. Thomas Date January 9, 2023

Print Name David L. Thomas, Title: Procurement Services Director

Seller's Signature  _____ Date 1.9.2023

Print Name M. HUGHES, Title: SVP, SALES

SOURCEWELL CONTRACT NO. 101221-GPV

GapVax[®]

PREPARED BY

AQUIP

AQUIP - ANNA JOHNSON, ANNA@AQUIPCO.COM

PREPARED FOR

Todd Davis

Beaufort County, South Carolina
120 Shanklin Rd
Beaufort, SC 29906

QUOTE

GapVax[®]



QUOTE ID
22xxx

UPDATED:
10/17/22



2023 MC1510-3S3X COMBINATION JET/VAC

QUOTE ID: 22xxx

October 21, 2022

NOTE: THE GAPVAX MC UNIT MAY EXCEED FEDERAL BRIDGE ALLOWABLE WEIGHTS WHEN LOADED WITH WATER, OR DEBRIS, AND/OR BOTH WATER AND DEBRIS COMBINED. PLEASE CONSULT FACTORY.

	OPTION DESCRIPTION	NOTES	QTY
CHASSIS OPTIONS			
CHA001	PETERBILT 548 (6 X 4) - 370 HP - 62,000 LB. GVWR - AUTO	MODEL YEAR 2023	1
	PACCAR PX-9 RATED FOR 370 HP	CONSULT FACTORY	
	ALLISON 6 SPEED AUTOMATIC	PRICES MAY VARY	
	20,000 LB FRONT AXLE		
	46,000 LB REAR AXLE		
	WHITE CAB COLOR		1
	CURRENT CARB EMISSIONS, CALIFORNIA AND NEW JERSEY		1
	STOCK CHASSIS ARE SUBJECT TO PRIOR SALE, LIMITED QUANTITY ARE AVAILABLE		1
DEBRIS BODY OPTIONS			
STD	10 USABLE YARD DEBRIS TANK MADE OF 3/16" ASTM A-572 GRADE 50 EXTEN STEEL		STANDARD
STD	FULL-OPENING REAR TAILGATE		STANDARD
STD	STAINLESS STEEL TAILGATE SEALING ROD		STANDARD
STD	FOUR HYDRAULIC REAR DOOR LOCKS		STANDARD
STD	DUAL TAILGATE LIFT CYLINDERS		STANDARD
STD	FRONT MOUNTED HOIST CYLINDER, POWER UP AND DOWN, 55,000 LB CAPACITY		STANDARD
STD	THREE TIE-OFF ANCHORS ON TOP OF BODY		STANDARD
STD	FIVE YEAR WARRANTY ON DEBRIS TANK AGAINST RUST THROUGH, DISTORTION AND CRACKS		STANDARD
STD	THREE TIE-OFF ANCHORS ON TOP OF THE BODY 6' APART		STANDARD
A1	DEBRIS BODY FLUSH OUT SYSTEM		1
A2A	DRAIN AT BOTTOM OF TAILGATE - 6" BRASS LEVER VALVE WITH 15' OF LAYFLAT HOSE	VALVE IS NOT 100% LEAK PROOF	1
A24A	DECANT HALF WAY UP TAILGATE - 6" BRASS LEVER VALVE WITH HANDLE		1
A3-CS	FLOAT TYPE LIQUID LEVEL INDICATOR ON SIDE OF DEBRIS TANK		1
A6AX	TRASH PUMP - SETUP ONLY	PUMP NOT INCLUDED	1
A11A	FILTER SCREEN FOR DRAIN VALVE (SHORT BOX)	REQUIRES A2	1
A12B	FILTER SCREEN FOR PUMP OFF SYSTEM (LONG BOX)	REQUIRES A5 OR A6	1
A21	CURBSIDE LADDER TO PORT INSPECTION AREA		1
A21B	ADD FOLDING LADDER EXTENSION	REQUIRES A21	1
A18	PURGE VALVE AT GRAVITY DRAIN (1-1/4" BALL VALVE)		1
A22A	GALVANIZED BOLT ON TAILGATE SPLASH SHIELDS		1
A37A	UPGRADE BODY INLET CANNON TO 12" HX STYLE WITH 3" CLEANOUT		1
A44	PNEUMATIC TAILGATE PROP (IN ADDITION TO STANDARD TAILGATE PROP ROD)		1
WATER TANK OPTIONS			
STD	1500 GALLON WATER TANK MADE OF 3/16" 304 STAINLESS STEEL		STANDARD
STD	4" HIGH ANTI-SIPHON RING WITH (4) 2-1/2" HOLES		STAND

STD	WATER TANK LEVEL SIGHT TUBE ON CURBSIDE	STANDARD
STD	DRAIN VALVE AT BOTTOM OF WATER TANK	STANDARD
STD	3" FILL LINE WITH 2-1/2" FIRE HOSE CONNECTION CURBSIDE	STANDARD
STD	3" WATER STRAINER WITH STAINLESS STEEL SCREEN ON WATER TANK FILL LINE	STANDARD
STD	3" SUPPLY LINE TO WATER PUMP MOUNTED AT REAR HINGE PIN	STANDARD
STD	FIVE YEAR WARRANTY ON WATER TANK AGAINST RUST THROUGH, DISTORTION AND CRACKS	STANDARD
B23A	GALVANIZED BAFFLES IN THE WATER TANK	1
B30	UPGRADE TO BUTTERFLY VALVE IN 3" SUPPLY LINE	STANDARD
VACUUM SYSTEM OPTIONS		
STD	TRUE 8" DIAMETER VACUUM SYSTEM	STANDARD
STD	VACUUM PUMP DRIVEN VIA MID-SHIP MOUNTED SPLIT SHAFT TRANSFER CASE GEARBOX (PTO)	STANDARD
STD	NOISE & VIBRATION DAMPENING MOUNTS ON VACUUM PUMP AND TRANSFER CASE	STANDARD
STD	NOISE ATTENUATED VACUUM PUMP DISCHARGE SILENCER WITH RAIN CAP AND DRAIN	STANDARD
STD	24" CENTRIFUGAL CYCLONE SEPARATOR WITH 20" CHAMBER	STANDARD
STD	DUAL STAINLESS STEEL SHUTOFF FLOAT BALLS MOUNTED AT THE REAR OF DEBRIS TANK	STANDARD
STD	STAINLESS STEEL VEE-WIRE SAFETY SCREEN	STANDARD
STD	6" SAFETY VACUUM RELIEF	STANDARD
STD	PANIC SWITCH FUNCTION FOR VACUUM	STANDARD
C8	UPGRADE TO ROOTS TYPE VACUUM PUMP 4,500 CFM AND 18" HG	(4) 18" Hg VACUUM RELIEF VALVES 1
C19	UPGRADE TO XL TRANSFER CASE	9-LITER ENGINE = UP TO 5300 CFM, REQUIRES OPTION C8 1
WATER SYSTEM OPTIONS		
STD	TRI-PLEX WATER PUMP SYSTEM	STANDARD
STD	800 PSI WASHDOWN CIRCUIT WITH 50' X 1/2" HOSE	STANDARD
STD	AIR PURGE SYSTEM FOR PRIMARY CIRCUIT	STANDARD
STD	LOW POINT DRAIN VALVES ON WATER LINES	STANDARD
STD	SET WASHDOWN CIRCUIT TO FULL WORKING PRESSURE	OPTION D4 IS RECOMMENDED 1
D3A	GIANT GP8000 SERIES WATER PUMP RATED 80 GPM @ 2,500 PSI	1
D4	UPGRADE TO URACA MULTIFLOW VALVE - SET WASHDOWN CIRCUIT TO FULL PRESSURE FOR HANDGUN APPLICATIONS	1
D7A	50' X 1/2" HAND GUN REEL FOR WASHDOWN CIRCUIT	1
D28A	GLYCOL INJECTION SYSTEM - JETTER PUMP ONLY	REQUIRES G2 1
D35B	1/2" HX LANCE WITH 6' EXTENSION AND RIPS AW NOZZLE	1
BOOM OPTIONS		
STD	8" FRONT MOUNTED TELESCOPING BOOM WITH 26' REACH AND 180 DEG. ROTATION	STANDARD
STD	180 DEGREE POWER ROTATION VIA WORM DRIVE	STANDARD
STD	DUAL 4" LIFT CYLINDERS	STANDARD
STD	CAB PROTECTION RACK	STANDARD
E6	REMOTE LUBE FOR BOOM LIFT AND ROTATION	1
HOSE REEL OPTIONS		
STD	FRONT FRAME MOUNTED HOSE REEL WITH 180 DEGREE ARTICULATION	STANDARD
STD	HOSE REEL RATED FOR 800' OF HOSE AND 3,000 PSI	STANDARD
STD	EXTERIOR HOSE EXPANSION RIBS	STANDARD
F1C	DIGITAL FOOTAGE COUNTER - SHAFT-MOUNTED	1
F11	AUTOMATIC HOSE LEVEL WINDER (INCLUDES "J-HOOK" STLYE HOSE GUIDE)	1
CONTROLS, GUGES, ACCESSORIES OPTIONS		
STD	CAB-MOUNTED AIR SHIFT CONTROLS FOR BLOWER, HYDRAULICS, AND WATER PUMP	STANDARD

Item 3.

STD	CONTROL PANEL MOUNTED AT FRONT HOSE REEL		STANDARD
STD	OPERATOR CONTROL PANEL INCLUDES GAUGES FOR ENGINE, HYDRAULICS, VACUUM, AND WATER PUMP		STANDARD Item 3.
STD	PANIC SWITCH TO RELIEVE WATER PRESSURE AND VACUUM		STANDARD
G2B	G2B CONTROL SYSTEM WITH DM430 DISPLAY INCLUDES:		1
	LOW WATER SHUTDOWN PROTECTION		1
	HIGH WATER TEMPERATURE SHUTDOWN PROTECTION		1
	ENGINE OVERSPEED PROTECTION		1
	ON-SCREEN DIAGNOSTICS FOR WATER, PTO AND ENGINE LEVELS		1
G6	BLOWER TEMPERATURE GAUGE WIRED TO VACUUM RELIEF		1
G16	BOOM UP LIGHT		1
G21D	WIRELESS REMOTE WITH BOOM, VACUUM, FRONT HOSE REEL WATER ON/OFF, AND FRONT HOSE REEL IN/OUT		1
G21-TD	UPGRADE TO AARCOMM TRIDENT REMOTE	REQUIRES OPTION G21	1
G21-AWR	ADDITIONAL WIRELESS TRANSMITTER	REQUIRES OPTION G19 OR G21	1
LIGHTING			
STD	TRUCK-LITE LED RUNNING (MARKER) LIGHTS		STANDARD
STD	LED STOP/TAIL/TURN LIGHT WITH POLISHED STAINLESS STEEL BOXES		STANDARD
H1	ONE LED STROBE BEACON LIGHT - FRONT (SAE CLASS-1 (SAE J595) COMPLIANT)	(WHELEN L10 OR EQUAL)	1
H5B	(2) BOOM WORK LIGHTS - HELLA LED WORK LIGHTS (PN: LHT022429)		1
H6B	(2) REAR WORK LIGHTS - HELLA LED WORK LIGHTS (PN: LHT022429)		1
H7BA	(2) SIDE WORK LIGHTS - HELLA LED WORK LIGHTS (PN: LHT022429) (1 PER SIDE)		1
H33	REAR ARROW LIGHT - LOW PROFILE LED (CA TITLE-13 COMPLIANT) TRAFFIC ADVISOR	(LHT022544, CODE 3 TORUS NARROWSTIK OR EQUAL)	1
STORAGE OPTIONS			
STD	25' FIRE HOSE BASKET		STANDARD
I6F-DS	STAINLESS STEEL, 36" WIDE X 24" TALL X 24" DEEP, MOUNTED ON THE DRIVER'S SIDE		1
I9C	48" TOOL BOX - STAINLESS STEEL, 48" WIDE X 24" HIGH X 24" DEEP, MOUNTED ON THE CURBSIDE		1
I14	TRAFFIC CONE HOLDER ON DRIVER'S SIDE		1
I16A	WHEEL CHOCK HOLDER (PER SIDE) - DRIVER'S SIDE		1
I16B	WHEEL CHOCK HOLDER (PER SIDE) - CURBSIDE		1
I17A	NOZZLE RACK - SIX (6) NOZZLES, 1"		1
I20A	REAR DRAIN HOSE RACK FOR 6" LAYFLAT HOSE X 15' LONG		1
I22	UPGRADE TUBE TRAYS TO POLISHED STAINLESS STEEL		1
I26C	TWO BUMPER TOOL BOXES - STAINLESS STEEL, 16" HIGH X 12" WIDE X 18" DEEP WITH FOLD DOWN DOOR		1
CHASSIS OPTIONS			
STD	DOT LIGHTING / FENDERS / MUD FLAPS / TAILGATE SAFETY PROP, ICC LIGHTS		STANDARD
STD	REMOTE ACTUATED BODY SAFETY PROP		STANDARD
STD	70 GALLONS AW-46 HYDRAULIC OIL, LEVEL/TEMPERATURE GAUGE, SHUTOFF ON SUCTION		STANDARD
STD	REAR BUMPER, TRIANGLE KIT, FIRE EXTINGUISHER, BACKUP ALARM		STANDARD
STD	ALLISON 10-BOLT PTO UPGRADE		STANDARD
J0	FRONT BUMPER - MAY NOT BE REQUIRED IN ALL STATES		1
J3	TOW HOOKS FRONT		1
J4B	TOW HOOKS REAR - FRAME MOUNTED		1
J12	METAL MUD FLAPS IN FRONT OF REAR TIRES		1
PAINT OPTIONS			
STD	PAINTED WITH PPG URETHANE PAINT		STANDARD
STD	PAINT BODY WHITE		STANDARD 189

STD	PAINT FRAME AND PARTS BLACK	STANDARD
STD	PAINT HOSE REEL AND BOOM BLACK	STANDARD
STD	FLEET FINISH	STANDARD
MISCELLANEOUS OPTIONS		
STD	25 FEET OF VACUUM TUBING (5) AND CLAMPS	STANDARD
STD	TIGER TAIL HOSE GUIDE	STANDARD
STD	TWO BLUE STAR SEWER CLEANING NOZZLES	STANDARD
M3	FILL HOSE 25' X 2 1/2"	1
M5C	LEADER HOSE 25' X 1"	1
M7K	1" PIRHANA SEWER HOSE - 3,000 PSI X 500 FT PLASTIC (BLUE) (PN: HOS022501)	1
M12	MANHOLE LIFTING HOOK	1
M13	HYDRANT WRENCH	1
M26	1" SIX WIRE EXTENDER	1
M27	TIGER TAIL (TOTAL OF TWO)	1
M28	(5) TRAFFIC CONES - 28" LIME GREEN WITH REFLECTIVE STRIPE	1
M29	ONE CAMERA - BACK-UP CAMERA SYSTEM WITH 7" COLOR MONITOR (RV-505A), INCLUDES DVR-916 REAR CAMERA	1
CUSTOM OPTIONS		
**	MATERIALS SURCHARGE (EFFECTIVE MAY 1, 2022)	1

Item 3.



PRICING SUMMARY

PRICE OF BASE UNIT WITH OPTIONS:	\$ 558,098.70
SOURCWELL DISCOUNT:	\$ 19,356.97
DELIVERY: (\$1,000.00 MINIMUM) @ \$3.00 PER MILE	\$ 1,800.00
ESTIMATED SUBTOTAL:	\$ 540,541.73
SALES TAX:	\$ -
FEDERAL EXCISE TAX (BODY):	\$ -
FEDERAL EXCISE TAX (CHASSIS):	\$ -
TOTAL PRICE (PER UNIT):	\$ 540,541.73

ALL PRICES ARE IN US DOLLARS

DUE TO EXTREME MARKET VOLATILITY AND PENDING U.S. GOVERNMENT SECTION 232 TRADE CASES ALL PRICES AND AVAILABILITY ARE SUBJECT TO CHANGE WITHOUT NOTICE, ALL QUOTES TO BE CONFIRMED AT TIME OF ORDER

***** FOB DESTINATION *****

SIGNATURE _____

DATE _____

Please return a signed copy to ANNA JOHNSON, ANNA@AQUIPCO.COM

QUOTE ID
22xxx

LAST UPDATED:
10/17/22

GapVax Incorporated

Terms and Conditions of Sale

1. **ORDERS.** All orders are subject to acceptance by an officer of GapVax Inc. Orders for products not regularly carried in stock or requiring special engineering or manufacture are in every case subject to approval by an officer of GapVax.
2. **PERFORMANCE.** GapVax Inc. shall not be liable for failure to complete the contract in accordance with its terms if failure is due to wars, strikes, fires, floods, accidents, delays in transportation or other causes beyond its reasonable control.
3. **EXPERIMENTAL WORK.** Work performed at customer's request such as sketches, drawings, design, testing, fabrication and materials shall be charged at current rates.
4. **SKETCHES, ENGINEERING DRAWINGS, MODELS** and all preparatory work created or furnished by GapVax Inc. shall remain its exclusive property; and no use of same shall be made, nor may ideas obtained therefrom be used, except with the consent of and on terms acceptable to GapVax Inc.
5. **CANCELLATION.** Orders regularly entered cannot be canceled except upon terms that will compensate GapVax Inc. for any loss or damage sustained.
6. **SHIPMENT.** All proposals are based on continuous and uninterrupted delivery of the order upon completion unless specifications distinctly state otherwise. In the event that an agreement is reached for GapVax Inc. to store completed items, they will be immediately invoiced to the customer and become due and payable. Storage shall be at the risk of the customer and GapVax Inc. shall be liable only for ordinary care of the property.
7. **CUSTOMER'S PROPERTY.** GapVax Inc. shall charge the customer at current rates, for handling and storing customer's property (e.g., truck chassis) held for more than thirty (30) days after notification of availability for shipment. All customer's property, or third party's property, that is stored by GapVax Inc. is at the customer's or other party's risk. GapVax is not liable for any loss or damage thereto caused by fire, water, corrosion, theft, negligence, or any cause beyond its reasonable control.
8. **PRICES.** All orders are subject to current prices in effect at the time of order acknowledgment. Prices and Specifications are Subject to Change Without Notice. **PRICING DISCLAIMER:** While we make every effort to maintain and preserve pricing accuracy, prices are subject to change without notice. Although the information on this quotation is presented in good faith and believed to be correct at the time of printing, we make no representations or warranties as to the completeness or accuracy of this information. We reserve the right to change, delete, or otherwise modify the pricing information which is represented herein without any prior notice. We carefully check pricing specifications, but occasionally errors can occur, therefore we reserve the right to change such prices without notice. We disclaim all liability for any errors or omissions in the materials. In no event will we be responsible for any damages of any nature whatsoever from the reliance upon information from these materials. Please check your order to confirm your pricing information.
9. **F.O.B. POINT.** Unless otherwise stated, all prices listed are F.O.B. point of manufacture.
10. **TAXES.** Unless specifically stated, prices listed do not include Federal, State, City or other excise occupation, sales, use or similar taxes which are extra and are to be added at rates in effect at time of shipment. If federal Excise Taxes are included or listed on the reverse side of this paper, they are stated at the rates and regulations in effect at the time this order is written and are subject to revision in accordance with rates and regulations in effect at time of shipment.
11. **PRODUCT IMPROVEMENT.** GapVax Inc. reserves the right to change manufacturing specifications and procedures without incurring any responsibility for modifying previously shipped products.
12. **MOUNTING PRICES.** Mounting prices assumes normal factory installation on a truck chassis suitable for the unit purchased. Relocation of batteries, gas tanks, mufflers, air tanks, etc. will be an additional charge, billed at the standard factory labor rate.
13. **WARRANTY.** GapVax Inc. warrants its products to be free from defects in material and workmanship, subject to the limitations and conditions set forth in its current published warranty but makes no warranty of merchantability or fitness for any particular purpose. GapVax Inc. does not assume liability for any loss of product, time or any direct, indirect, or consequential damage, losses or delay or any nature whatsoever. No warranty, express or implied, is made or authorized to be made and no obligation is assumed or authorized to be assumed with respect to products of GapVax Inc. other than that set forth in the current, published warranty. It is to be understood that the acceptance this order is expressly conditioned upon your acceptance of GapVax Inc. standard written warranty for the products sold hereunder. GapVax Inc. hereby disclaims any responsibility or liability for any consequential losses delays or downtime resulting from orders hereunder the use of its products. GapVax does not and will not warranty any tank coating or tank lining. PTO damage is not covered when the PTO protection system or low water shut down system is not selected / installed / and operational. GapVax does not and will not warranty any water system component(s) that show any sign or indication of ice or freeze damage.
14. This agreement shall be construed according to the laws of the State of Pennsylvania. Our failure at any time to exercise any right we may have under the agreement shall not constitute a waiver thereof nor prejudice our right to enforce same thereafter.
15. This order, including the above terms and conditions contains the complete and final agreement between the parties hereto and no other agreement in any way modifying any of said terms and conditions will be binding on us unless in writing and agreed to by authorized representative of this company.

GapVax



GARVAX MC SERIES
COMBINATION JETVAC

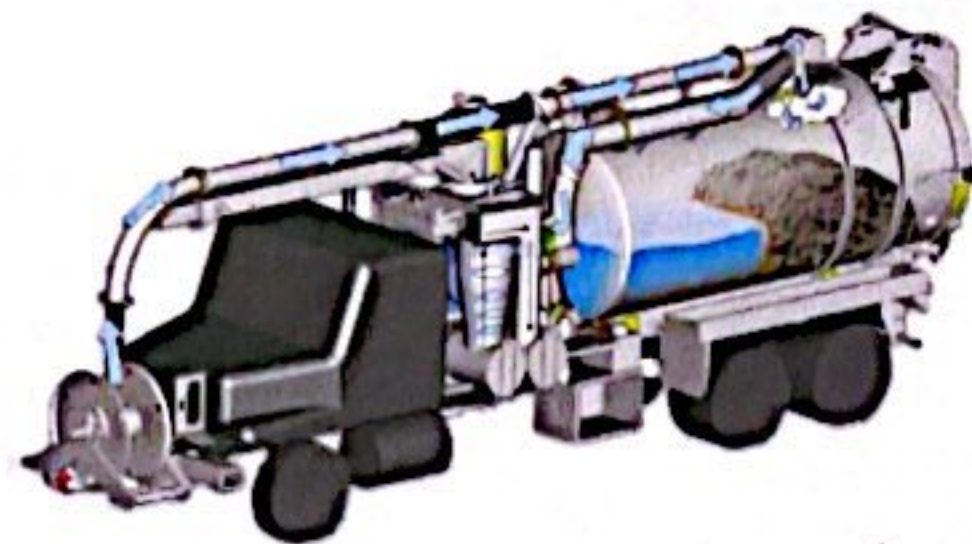

VACUUM SYSTEM:

- Positive displacement pump; 3,500 CFM, 16" Hg
- 500 HP transfer case with air-shift engagement
- Optional 4,000 CFM/27" Hg PD Blower

4,500 CFM, 18" HG PD BLOWER



BOOM SYSTEM:

- 8" Telescoping boom, with a 180° rotation
- Standard 9' extension, 26' reach from center
- Heavy duty dual lift cylinders
- Worm gear driven

8" TUBE IN TUBE BOOM

EXTENDED FRONT FRAME RAIL

FRONT HOSE REEL:

- 180° Rotation
- Hydraulically powered direct-drive gearbox
- 1"x800'; 1-1/4" x500'; or 3/4"x1,200' reel capacity
- Optional auto-level wind
- Fully enclosed control panel

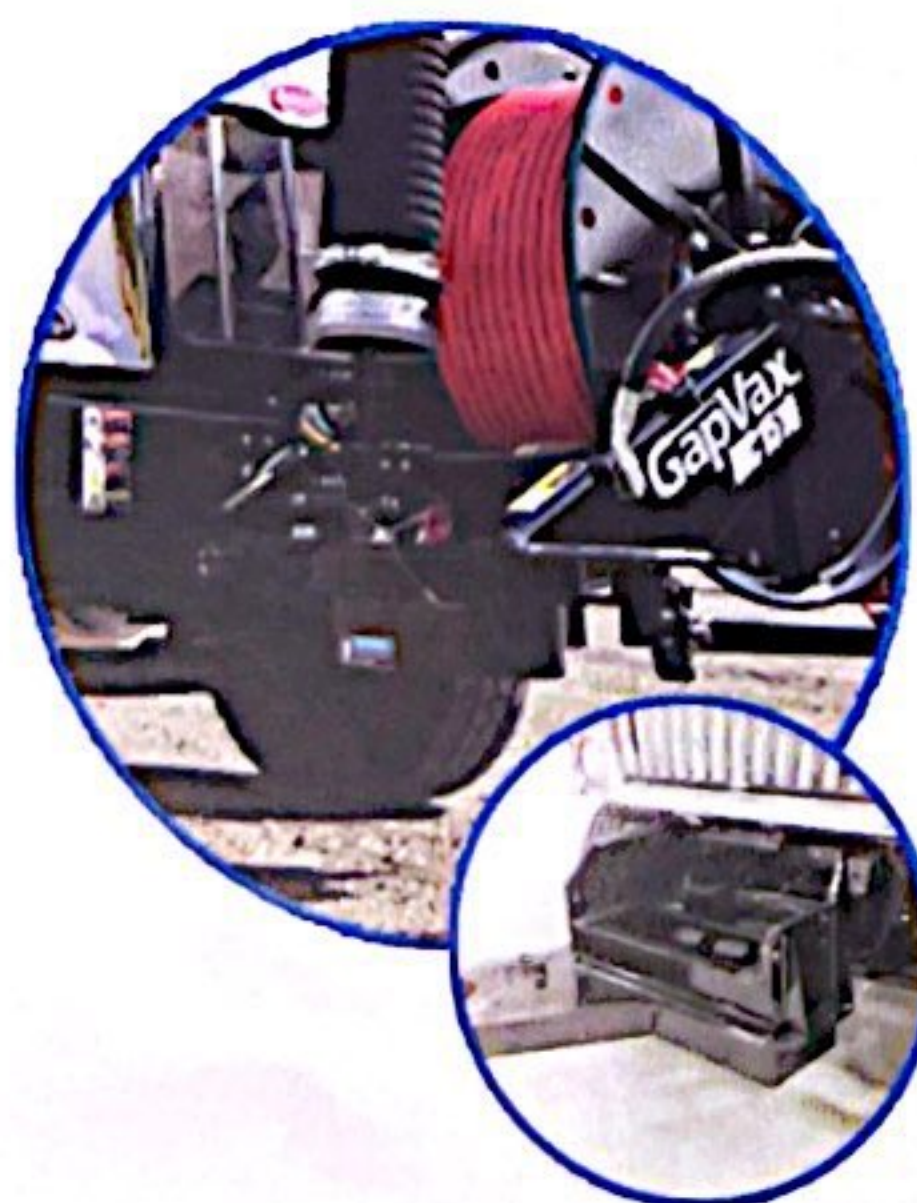
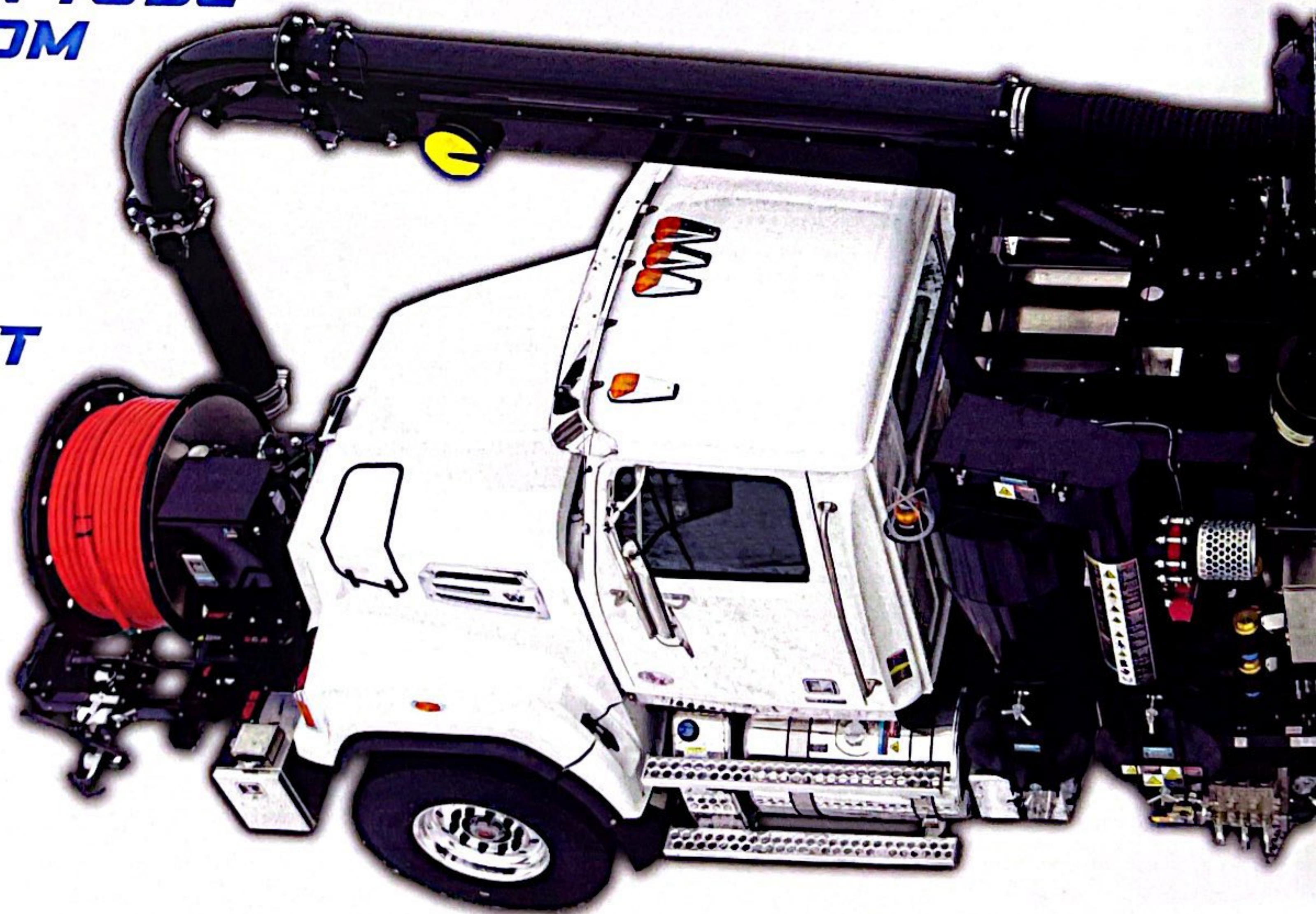

80 GPM; 2,000 PSI

WATER SYSTEM:

- 500-2,000 gallon water tank capacity
- Stainless steel water tank
- Shaft-driven Tri-plex water pump
- Optional water pump flow up to 100 GPM and PSI up to 3,000

VERSATILE.

RELIABLE.

the operator, making it ideal for contractors and municipalities alike.

will only build our hose reels on trucks with extended front frame rails supplied by the chassis OEM. Using extended rails
gure, and provides effortless control while operating.

n to last longer and cost less to maintain than other brands. You can trace this longevity back to our full-length 6" steel
chassis frame and minimizes frame flexing while driving or operating the boom. Building on a solid foundation reduces stress,
and perform better.

n 3/16" stainless steel. Plus, it's located well above the truck's frame, protecting it from the accidental scrapes and punctures that

FILTRATION:

- 10" Stainless steel floatball shutoff
- Centrifugal cyclone separator with full-opening door, 20" cleanout and removable vortex finder
- Washable, stainless steel vee wire screen (300 micron)

MULTI-STAGE FILTRATION

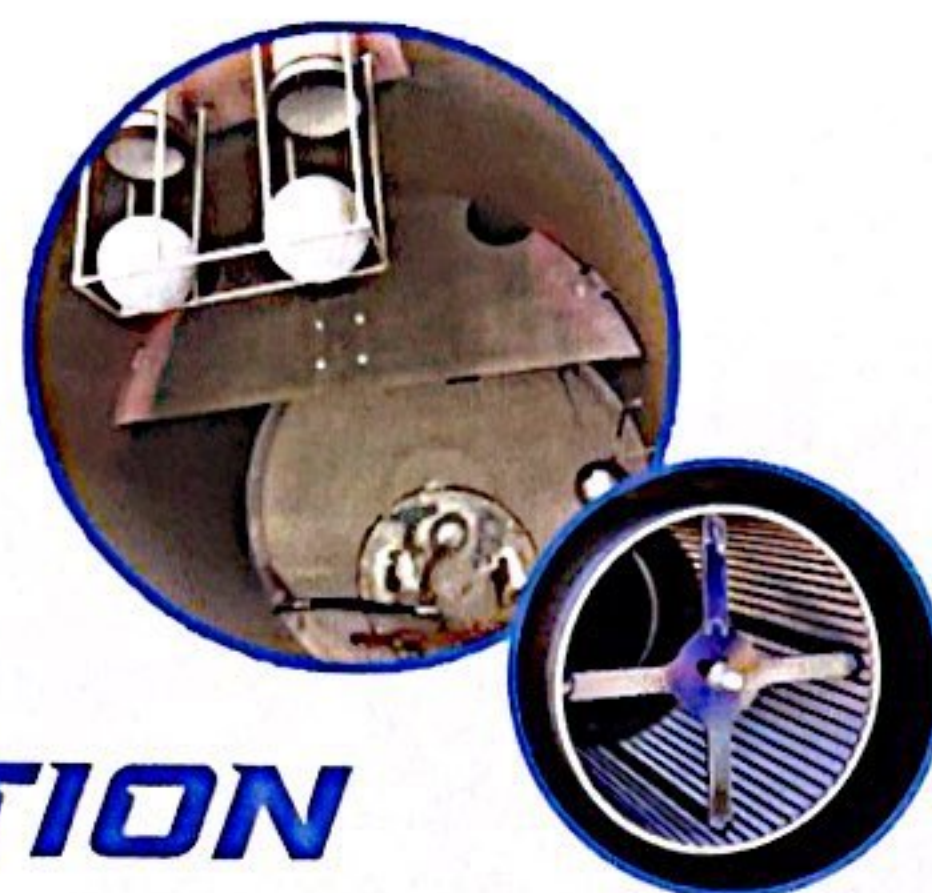

OTHER FEATURES INCLUDE:

- Mid-ship transfer case directs the power of the engine to the blower and hydraulic system
- Noise and vibration dampening mounts for blower
- Full length 6" subframe to reinforce strength and allow for tube trays

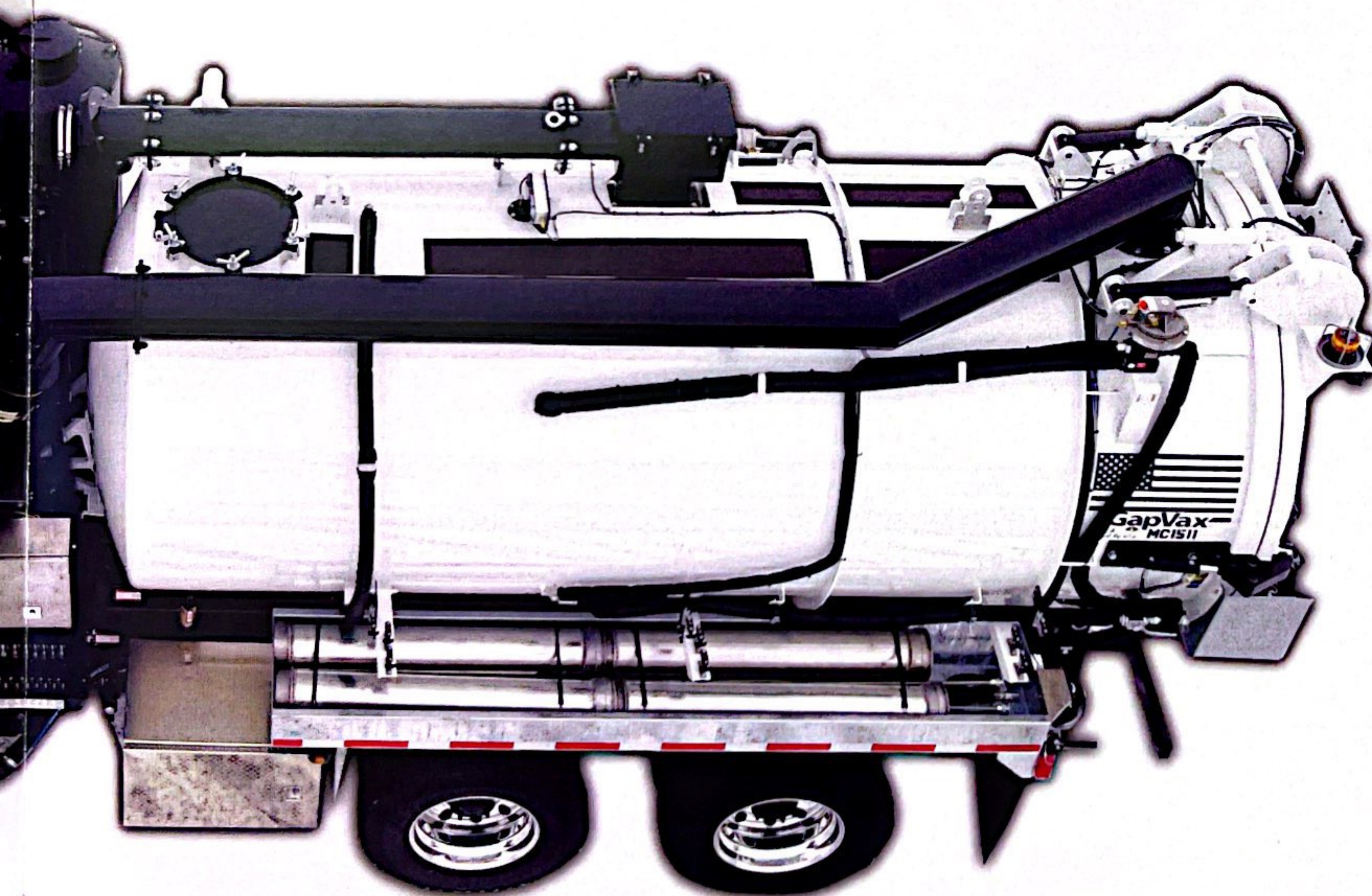

OPTIONS:

- Stainless steel debris body
- HX package
- Pump-off systems
- Body flush-out system
- Interior coating in debris tank
- Lateral hose reel kit
- Hydraulic tool circuit
- Wireless remote/pendant
- Storage options
- Lighting options

*See website for complete listing
gapvax.com

TOP LOADING BODY

DEBRIS BODY:

- 5-13 cu. yd. debris body options
 - *Single axle configurations available
- Double acting lift cylinder that provides a stable 50° dump angle for fast unloading and easy clean-out
- Full opening tailgate with four fail-safe locks; locks are "field-adjustable" with a simple wrench



*SPECS SUBJECT TO CHANGE WITHOUT NOTICE

JURABLE.

GAPVAX
MC
SERIES
 COMBINATION JETVAC



LOOKING FOR A SINGLE AXLE? WE'VE GOT YOU COVERED!

- 4 - 8 cu. yd. debris body options available
- Most features and options offered in the tandem model are the same for the single. Talk to your sales rep to find out more!



G2X NEXT LEVEL PERFORMANCE

- Push-button operation with on-screen instruction
- Touch screen engagement from the front control box (optional in cab)
- Capability to move the front hose reel from inside the cab
- Smooth operation with joystick and wireless controls
- Dump and Washout functions on wireless controls
- Curbside dump capabilities
- Water and fuel consumption trackers, job card and more
- Complete system and chassis diagnostics

Ask about the G2X option for your MC Series Combo unit!

Your authorized
 GapVax Dealer:



GapVax Gulf Coast
 4510 Underwood Rd
 La Porte, TX 77571
 281-884-8658



Headquarters
 575 Central Ave.
 Johnstown, PA 15902
 888-442-7829